



Llywodraeth Cymru  
Welsh Government



GIG  
CYMRU  
NHS  
WALES

Partneriaeth  
Cydwasanaethau  
Gwasanaethau Ystadau Arbenigol  
Shared Services  
Partnership  
Specialist Estates Services

# WHTM 04-01

## Supplement

Welsh Health Technical Memorandum

# Performance specification D 08: thermostatic mixing valves (healthcare premises)

2017 edition

## Disclaimer

The contents of this document are provided by way of general guidance only at the time of its publication. Any party making any use thereof or placing any reliance thereon shall do so only upon exercise of that party's own judgement as to the adequacy of the contents in the particular circumstances of its use and application. No warranty is given as to the accuracy, relevance or completeness of the contents of this document and NHS Wales Shared Services Partnership – Specialist Estates Services shall have no responsibility for any errors in or omissions there from, or any use made of, or reliance placed upon, any of the contents of this document.

**Note:** Heath Building Notes (HBNs) and Health Technical Memoranda (HTMs) issued by the Department of Health in England are being superseded by specific Welsh editions, which will be titled Welsh Heath Building Notes (WHBNs) and Welsh Health Technical Memoranda (WHTMs) and which will use the same numerical coding. When using these guidelines, always refer to the relevant publications page on the NHS Wales Shared Services Partnership – Specialist Estates Services website for the latest approved document, particularly where an HBN or HTM is referred to in the text.

Intranet: <http://howis.wales.nhs.uk/sites3/page.cfm?orgid=254&pid=39106>

Internet: <http://www.wales.nhs.uk/sites3/page.cfm?orgid=254&pid=6142>

Published by NHS Wales Shared Services Partnership – Specialist Estates Services

This guidance is based on the HTM 04-01 Supplement, *Performance specification D 08: thermostatic mixing valves (healthcare premises)* 2017 edition, published by the Department of Health.

It replaces HTM 04-01 Supplement: 2016

This publication can be accessed from the NHS Wales Shared Services Partnership – Specialist Estates Services website [www.wales.nhs.uk/ses](http://www.wales.nhs.uk/ses)

© Copyright NHS Wales Shared Services Partnership – Specialist Estates Services 2017

## Acknowledgements

WHBN 04-01 *Supplement. Performance specification D 08: thermostatic mixing valves (healthcare premises)*, is based on the Department of Health HTM 04-01:2017, *Supplement. Performance specification D 08: thermostatic mixing valves (healthcare premises)*. NHS Wales Shared Services Partnership – Specialist Estates Services is grateful to the Department of Health for permission to adapt the original guidance for application in Wales. The contents of the original document were reviewed by NHS Wales Shared Services Partnership – Specialist Estates Services and by representatives of health boards and Trusts in Wales and Welsh Government.

# Contents

## Acknowledgements

## Introduction

Key certification scheme requirements for Type 3 thermostatic mixing valves

## Chapter 1 Scope

## Chapter 2 Definitions

## Chapter 3 Construction

General  
Materials

## Chapter 4 Sampling

## Chapter 5 Leaktightness

General  
Principle  
Apparatus  
Leaktightness of the thermostatic mixing valve upstream of the obturator and of the obturator  
Leaktightness of the obturator of the thermostatic mixing valve: cross flow between hot and cold water  
Leaktightness of the thermostatic mixing valve downstream of the obturator  
Leaktightness of the manual diverter of the thermostatic mixing valve  
Leaktightness of the diverter with automatic return of the thermostatic mixing valve

## Chapter 6 Durability

Durability of on/off (flow) control  
Durability of diverters  
Durability of thermostat

## Chapter 7 Performance

General  
Sequence of tests  
Flow rate and sensitivity of temperature control  
Initial settings for thermal performance tests  
Mixed water temperature overshoot on operation of diverter (manual or automatic return)  
Mixed water temperature overshoot on operation of second outlet  
Mixed water temperature overshoot on starting from ambient  
Mixed water temperature overshoot on adjustment of mixed water temperature

Thermal shut-off  
Temperature stability with changing water supply pressure  
Temperature stability with changing water supply temperature  
Temperature stability at reduced flow rate

Chapter 8 Designation

Chapter 9 Marking

Chapter 10 Installation and operating instructions

Chapter 11 Commissioning and in-service tests

Commissioning  
In-service test  
TMV test record sheet  
Commissioning and in-service test results (clauses 11.1 or 11.2)  
Frequency of in-service test (Annex F)

Annex A (normative)	apparatus for durability test on thermostat
Annex B (normative)	apparatus for performance tests
Annex C (normative)	determination of thermometer response time
Annex D (normative)	testing of further samples
Annex E (informative)	assessment of transient values
Annex F (informative)	frequency of in-service tests
Annex G (normative)	flow rate and sensitivity test of temperature control (alternative to angular or linear movement)

References

## Introduction

It is recognised that users of domestic hot water for ablutionary purposes in health and social care establishments, particularly vulnerable people (see Note below), can be at risk of injury by scalding. The previous edition of this performance specification, published in 1997, was developed in response to a requirement to provide a robust performance-based specification standard for thermostatic mixing valves for use in the healthcare sector that would significantly reduce the risk of water being emitted at an unsafe temperature.

### Note

“Vulnerable people” are defined by the Health and Safety Executive (2012) as:

- children;
- older people;
- people with reduced mental capacity, mobility or temperature sensitivity;
- people who cannot react appropriately, or quickly enough, to prevent injury.

This updated specification has been amended in conjunction with NSF, BuildCert, TMV manufacturers and trade bodies. In addition to amendments to the technical content relating to the performance requirements, material requirements and test methods for thermostatic mixing valves, it contains flowcharts to assist with the on-site:

- auditing of the water supply conditions intended to supply the thermostatic mixing valve;
- commissioning of the thermostatic mixing valve;
- in-service testing of the thermostatic mixing valve.

These flowcharts are intended to assist those responsible for the installation, commissioning and routine in-service testing of thermostatic mixing valves in ensuring that the installed equipment operates as intended by the manufacturer, and delivers safe hot water for the user.

This performance specification is intended to be utilised in conjunction with WHTM 04-01:2016 Parts A, B & C (which include information on *Pseudomonas aeruginosa*).

## Key certification scheme requirements for Type 3 thermostatic mixing valves

The certification requirements to enable manufacturers to demonstrate compliance with WHTM 04-01: Supplement *Performance Specification D 08: thermostatic mixing valves (healthcare premises)* were initially established in the mid-1990s following a joint initiative by the four devolved nations (led by NHS Estates) in conjunction with Water Research Centre (now NSF) and thermostatic mixing valve manufacturers.

These requirements have been amended in subsequent years. Historically, recommendations from the BuildCert/NSF Technical Assessment Panel (TAP) in relation to the certification scheme have been presented formally to the TMV Industry Forum where decisions are ratified, minuted and notified to the Department of Health (DH). Where there have been any challenges to the scheme requirements, these have been heard by an independently chaired advisory committee (BuildCert/NSF Advisory Committee). Decisions of this independent committee are also notified to DH.

Any third-party certification schemes for Type 3 thermostatic mixing valves must incorporate ALL of the following key requirements:

- The certification organisation must be UKAS-accredited against BS EN ISO/IEC 17065 and must be open to inspection by DH or its nominated representative.
- The test houses that provide performance results against WHTM 04-01: Supplement *Performance Specification D 08: thermostatic mixing valves (healthcare premises)* must be UKAS-accredited against BS EN ISO/IEC 17025.
- Test houses must enter into round-robin verification every five years to ensure reproducibility of results.
- Manufacturers' test houses must have additional third-party witness verification of sample selection and testing to ensure full third-party approval is maintained.
- Type 3 approval is issued for five years, after which a full re-test will be required.
- A list of the approved Type 3 valves from the scheme should be freely available online in an easy-to-access format.
- Manufacturers must have in place a UKAS-recognised ISO 9001 quality system.
- Approved Type 3 valves must be performance-audited twice within the five-year approval period with failures notified to DH and systems established to eliminate risks to users.

- Identification (the manufacturer's unique mark or identifier) of Type 3 valves should be verified twice within the five-year approval period.
- Installation documentation provided with Type 3 valves should be verified twice within the five-year approval period.
- Regular liaison with the TMV industry (that is, manufacturers and trade associations) and DH should be maintained to ensure industry has access to the certification scheme and can input directly into the requirements of the approval process.

Any suggested amendments to the requirements in WHTM 04-01:2017 Supplement *Performance Specification D 08: thermostatic mixing valves (healthcare premises)* should be discussed formally with DH or its nominated representative.





## Chapter 1

# Scope

This specification specifies the performance, material requirements and test methods for thermostatic mixing valves for use in care establishments (for example hospitals, nursing homes, and residential care homes etc) where the users (for example patients, residents etc), by virtue of their physical or mental condition, are deemed to be at greater risk of injury in their use of domestic hot water than would be the case for normally able persons in their own dwelling. Thermostatic mixing valves complying with this specification are also suitable for other applications where the risk of scalding must be reduced.

### Note 1

An assessment of the risk should be carried out.

Thermostatic mixing valves complying with this specification are designated according to operating pressure range and the intended ablutionary application (see [Chapter 8](#)).

### Note 2

Application for washbasin use is included for those situations where the risk assessment shows that a greater level of protection is necessary.

This specification applies to thermostatic mixing valves installed for ablutionary purposes in care establishments in which the hot and cold water supplies are normally within the limits specified in [Table 1](#) for each operating pressure range and the mixed water temperature is set to the value specified in [Table 2](#) appropriate to the application.

### Note 3

Some of the performance requirements represent the application of abnormal water supply conditions outside these limits to ensure that under specified fault conditions the mixed water temperature remains safe.

Thermostatic mixing valves having integral on/ off, or flow control, for single-point use are included in the scope of this specification. Thermostatic mixing valves without flow control and those suitable for supplying a small number of outlets are also included.

### Note 4

Multiple outlets should not be considered where the length of the downstream dead-leg may aggravate the risk of bacterial growth.

Guidance on this is given in WHTM 04-01:2016 Part A: *Safe water in healthcare premises. Part A: Design, installation and commissioning.*

Thermostatic mixing valves with a user-adjustable mixed water temperature up to a pre-set maximum and thermostatic mixing valves intended to be installed and used with no user-accessible adjustment of the mixed water temperature are both included in the scope of this specification.



**Note 5**

Only thermostatic mixing valves with no user-accessible adjustment of the mixed water temperature should be used for applications in which two or more outlets may discharge simultaneously when operated by two or more users at the same time. Thermostatic mixing valves with user-accessible adjustment of the mixed water temperature may be used with two or more outlets that do not discharge simultaneously (for example, they are supplied through a diverter) provided that the mixed water temperature adjustment is appropriate to each application.

**Note 6**

When designations of use are referred to in this document, if prefixed by a “/” (forward slash symbol), the valve will have multiple designations of use. For example, a valve designated as HP-B/S/W, LP-B/S is approved for “high pressure bidet, shower and washbasin” and “low pressure bidet and shower use” only.

Thermostatic mixing valves of nominal size up to and including DN 25 are included in the scope of this specification.

Operating pressure range	High pressure	Low pressure
Maximum static pressure (bar)	10	10
Flow pressure, hot and cold (bar)	1 to 5	0.2 to 1
Hot supply temperature (°C)	55 to 65	55 to 65
Cold supply temperature (°C)	5 to 20	5 to 20

*Table 1 Conditions for normal use*



Application and designation	Mixed water temperature (at point of discharge)(°C)
Bidet (B)	38 max.
Shower (S)	41 max.
Washbasin (W)	41 max.
Bath (44°C fill) (T44)	44 max.
Bath (46°C fill) (T46)	46 max.
Diverter Bath/Shower (D44)	Bath fill 44 max, Shower 41 max
Diverter Bath/Shower (D46)	Bath fill 46 max, Shower 41 max
<p>Note 1: For washbasins, washing under running water is assumed.</p> <p>Note 2: Bath fill temperatures of more than 44°C should only be available when the bather is always under the supervision of a competent person (e.g. nurse or care assistant).</p> <p>Note 3: A thermostatic mixing valve having multiple designations (see Note 6 above) (i.e. it is capable of satisfying the requirements of this specification for more than one application) should be re-set on site to suit its other designations.</p> <p>Note 4: A thermostatic mixing valve having a diverter designation (D) must be capable of changing and controlling the mixed water outlet temperature as defined above when the supply path is changed from bath to shower or shower to bath.</p>	

Table 2: Mixed water temperature



## Chapter 2

# Definitions

### **Atmospheric discharge nozzle:**

an integral open outlet water spout that may include aerators, flow straighteners and flow regulators.

### **Obturator:**

mechanism that arrests the water flow (on/off control).

### **Pre-set:**

in respect of the mixed water temperature, this means that there is no user-accessible adjustment and the mixed water temperature is set to a fixed value. The fixed value is set on commissioning of the installation and shall not exceed the maximum permitted for the application (see [Table 2](#)).

### **Thermostatic mixing valve:**

valve with one or more outlets, which mixes hot and cold water and automatically controls the mixed water to a user-selected or pre-set temperature.

### **Note**

If provision for controlling the flow rate between no flow and maximum flow is included, this may be by means of a different motion of the temperature control or by a separate control (see [Annex G](#)).

### **Transient:**

measurement of temperature change over time.

### **User adjustable:**

in respect of the mixed water temperature, this means that there is a control accessible to the user which enables the temperature to be adjusted between a pre-determined maximum and some lower value. The pre-determined maximum is set on commissioning of the installation and shall not exceed the maximum permitted for the application (see [Table 2](#)).



## Chapter 3

# Construction

## 3.1 General

If the thermostatic mixing valve is provided with removable devices (for example, flow rate regulators) in the inlets, and these are intended to be removed on commissioning in order to convert the mixing valve to another designation, then the mixing valve shall be supplied with these devices fitted.

## 3.2 Materials

All materials in contact with water shall comply with the BS 6920 series and the current version of the Water Regulations Advisory Scheme's (WRAS) *A guide for manufacturers, suppliers and test laboratories on the application requirements for WRAS material approval* (2013).

## 4

## Chapter 4

## Sampling

The samples required for testing shall be selected at random from stock. In the event that one sample should fail to satisfy a designation, then **Annex D** shall be referred to. **Annex D** describes a provision for the testing of further samples. If two valves fail to satisfy a designation, then no further testing shall be undertaken.

When tested, the thermostatic mixing valve shall be fitted with the anti-backsiphonage devices (for example check valves) required in use. These shall be integral with the mixing valve, or supplied with it, or be specified by the manufacturer. If not fitted to the test samples, these devices shall be fitted in the connected pipework as close as possible to the mixing valve.

For the tests described in Chapters 5, 6 and 7, three samples are required, denoted by A, B and C. These shall be tested in the sequence shown in **Figure 1**.

Where two applications are served by two separately operating mechanisms sharing common supply connections, each operating mechanism shall be tested as though it were a separate valve. Only sample A shall be tested for flow rate according to **clause 7.3**. Where samples B and C utilise alternative inlet connection sizes, the flow rate will need to be verified for the appropriate designation.

For valves with designations D44 and D46, samples A and C shall be tested to the requirements of **clauses 7.4 to 7.12** for all relevant applications.

In all other cases, samples A and C shall be tested to the requirements of **clauses 7.4 to 7.12** for the designation in each operating pressure range having the highest mixed water temperature setting of those designations, or applications, with the lowest designated flow rate.

For all valves, sample B shall be tested to the requirements of **clauses 7.4 to 7.12** for all applications.

**Note**  
As an example, the performance tests applicable to designations HP-B/W/T44 and LP-B/W/T44 are shown in **Figure 2**.

4

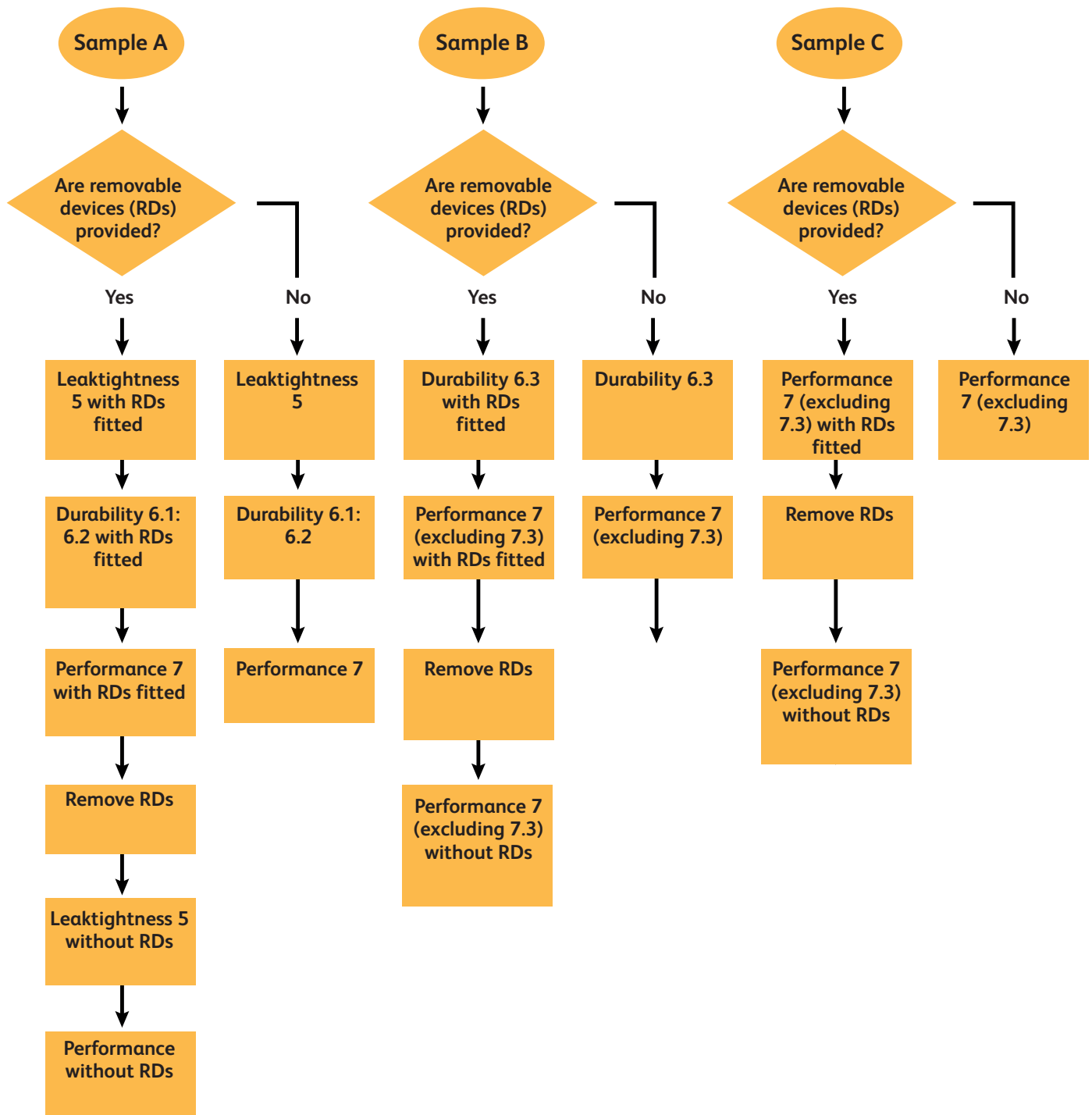
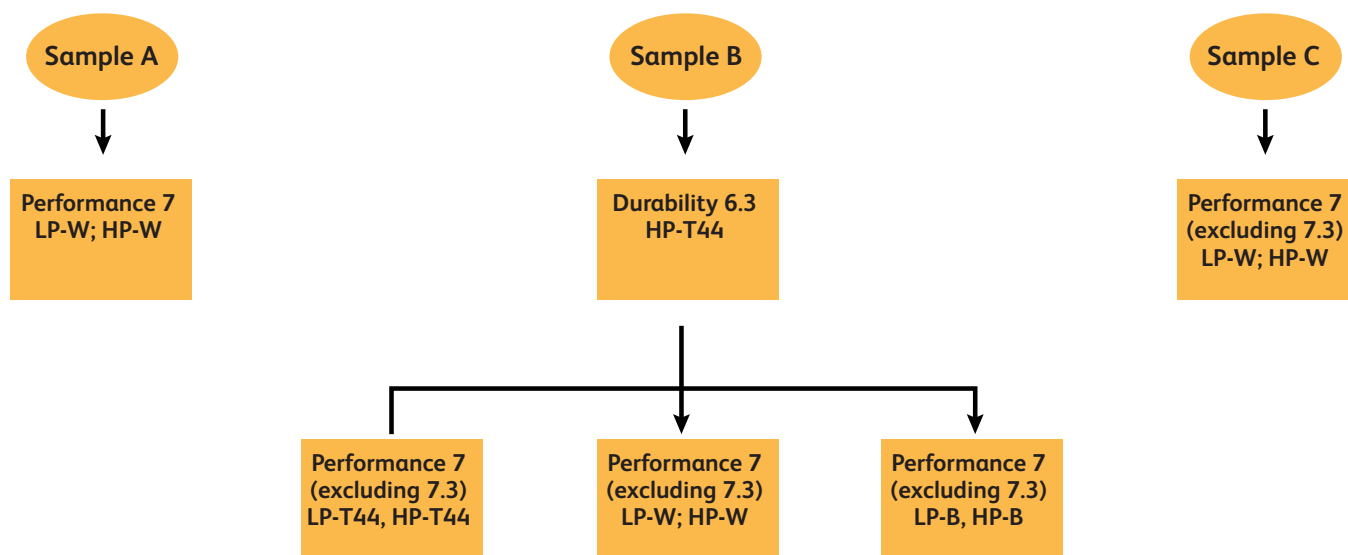

Figure 1: Test sequence

4



Flow rate tests to be undertaken for bath and other uses

Figure 2: Example of performance test sequence for designations - HP-B/W/T44 and - LP-B/W/T44



## Chapter 5

# Leaktightness

## 5.1 General

Thermostatic mixing valves certified as complying with either BS EN 1111:1999 or BS EN 1287:1999 will be regarded as complying with the leaktightness requirements of this specification. In all other cases the following tests shall be applied and shall be tested without shower hoses.

### Note

The tests described here reproduce almost exactly the text of the ENs referred to.

## 5.2 Principle

This consists of checking, under cold water pressure, the leaktightness of:

- a. the obturator (see [clauses 5.4](#) and [5.5](#)) if provided;
- b. the complete mixing valve (see [clauses 5.4](#) and [5.6](#));
- c. diverters with manual control (see [clause 5.7](#)) or automatic return (see [clause 5.8](#)) if provided.

### Note

Where a diverter with automatic return is regarded as performing an anti-backsiphonage function, additional requirements may be applied.

## 5.3 Apparatus

A hydraulic test circuit as shown in [Figure A.1](#) capable of supplying the static and dynamic pressures required and of maintaining them throughout the duration of the test.

## 5.4 Leaktightness of the thermostatic mixing valve upstream of the obturator and of the obturator

In the case of thermostatic mixing valves without obturators (that is, with no on/off or flow control), the outlet orifice shall be artificially closed.

#### 5.4.1 Procedure

- Connect the two water supplies to the mixing valve.
- With the outlet orifice open and the obturator closed, apply a water pressure of  $16 \pm 0.5$  bar to the thermostatic mixing valve for  $60 \pm 5$  s for the full operating range of the temperature control device.

In the case of single sequential thermostatic mixing valves, the control shall be left in the “flow closed” position.

#### 5.4.2 Requirements

- a. Verification of leaktightness upstream of the obturator.  
For the duration of the test there shall be no leakage or seepage through the walls.
- b. Verification of leaktightness of the obturator.  
For the duration of the test there shall be no leakage at the obturator.

## 5.5 Leaktightness of the obturator of the thermostatic mixing valve: cross flow between hot and cold water

In the case of thermostatic mixing valves without obturators (that is, with no on/off or flow control), the outlet orifice shall be artificially closed.

When testing a single sequential thermostatic mixing valve, the control shall be left in the “flow closed” position.

#### 5.5.1 Procedure

- Connect one inlet of the thermostatic mixing valve to the test circuit.
- With the outlet orifice open and the obturator closed, apply a water pressure of  $4 \pm 0.2$  bar to the thermostatic mixing valve for  $60 \pm 5$  s for the full operating range of the temperature control device.
- Repeat the test, reversing the water supply connection to the other inlet.

#### 5.5.2 Requirements

For the duration of the test there shall be no leakage or seepage at the outlet (not applicable to thermostatic mixing valves without obturator) or at the end of the unconnected inlet.

## 5.6 Leaktightness of the thermostatic mixing valve downstream of the obturator

### 5.6.1 Procedure

- Connect the two water supplies to the thermostatic mixing valve.
- With the outlet orifice closed and the obturator open, apply a water pressure of  $4 \pm 0.2$  bar to the thermostatic mixing valve for  $60 \pm 5$  s for the full operating range of the temperature control device.
- Repeat the test with a water pressure of  $0.2 \pm 0.05$  bar for  $60 \pm 5$  s.

### 5.6.2 Requirements

For the duration of the test there shall be no leakage or seepage.

## 5.7 Leaktightness of the manual diverter of the thermostatic mixing valve

### 5.7.1 Procedure

- Connect the thermostatic mixing valve, in its position of use, to the test circuit.
- Put the diverter in the bath position, with the bath outlet artificially closed and the shower outlet open.
- Apply the static water pressure appropriate to the designation given in [Table 3](#) for  $60 \pm 5$  s. Observe the outlet to shower.
- Gradually reduce to a static water pressure of  $0.2 \pm 0.05$  bar and maintain for  $60 \pm 5$  s. Observe the outlet to shower.
- Put the diverter in the shower position with the shower outlet artificially closed and the bath outlet open.
- Apply the static water pressure appropriate to the designation given in [Table 3](#) for  $60 \pm 5$  s. Observe the bath outlet.
- Gradually reduce to a static water pressure of  $0.2 \pm 0.05$  bar and maintain for  $60 \pm 5$  s. Observe the bath outlet.



Abbreviated designation	Static water pressure (bar)
All -LP-	$2 \pm 0.1$
All -HP-	$4 \pm 0.2$

Table 3 Test pressures for manual diverters

### 5.7.2 Requirements

For the duration of the test there shall be no leakage at the outlet points indicated.

## 5.8 Leaktightness of the diverter with automatic return of the thermostatic mixing valve

### 5.8.1 Procedure

- Connect the thermostatic mixing valve, in its position of use, to the test circuit with the outlets fully open.
- Put the diverter in the bath position and apply a dynamic water pressure equal to the “initial flow pressure”, appropriate to the designation, given in **Table 4** for  $60 \pm 5$  s. Check for leakage at the shower outlet.
- Fit to the shower outlet the hydraulic resistance identified in **Table 4** appropriate to the designation (see **Figure 3**).
- Maintaining the flow pressure at the “initial” value, put the diverter in the “flow to shower” mode. Observe the bath outlet for  $60 \pm 5$  s and note any leakage.
- With the diverter still in the shower position, reduce the dynamic pressure to a value equal to the “reduced flow pressure”, appropriate to the designation, given in **Table 4**. Check that the diverter is not dislodged. Maintain this pressure for  $60 \pm 5$  s and observe the bath outlet and note any leakage.
- Turn the water off. Check that the diverter returns to the bath position.
- Disconnect the hydraulic resistance and reopen the flow control and pressure measuring devices. Reapply the dynamic pressure equal to the “reduced flow pressure”, appropriate to the designation, given in **Table 4** for  $60 \pm 5$  s. Check for leakage at the shower outlet.

### 5.8.2 Requirements

For the duration of the test there shall be no leakage.

5

Abbreviated designation	Initial flow pressure (bar)	Reduced flow pressure (bar)	Flow resistance
All -LP-	0.8 ± 0.04	0.2 ± 0.01	Complying with Figure 3 and calibrated to a flow rate of 9 L/min at a flow pressure of 0.2 bar referenced to the datum shown
All -HP-	4 ± 0.2	0.5 ± 0.05	A flow resistance calibrated to a flow rate of 15 L/min at a flow pressure of 3 bar

Table 4 test pressures and flow resistances for diverters with automatic return

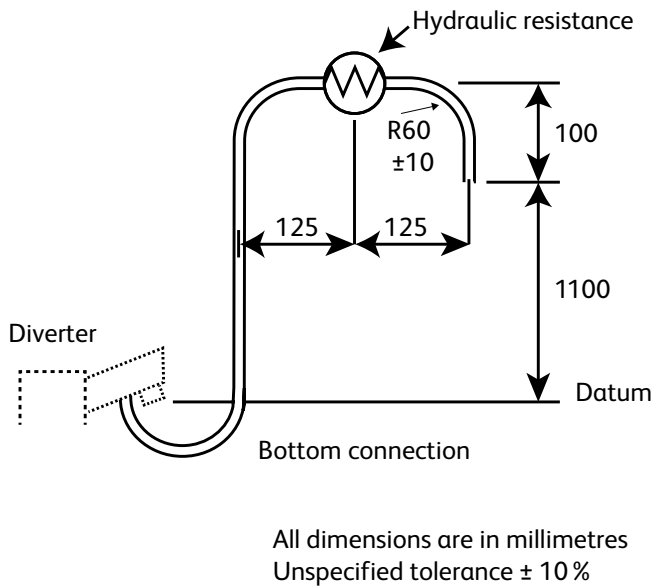

Tube to be of same nominal size as the diverter connection for the shower outlet

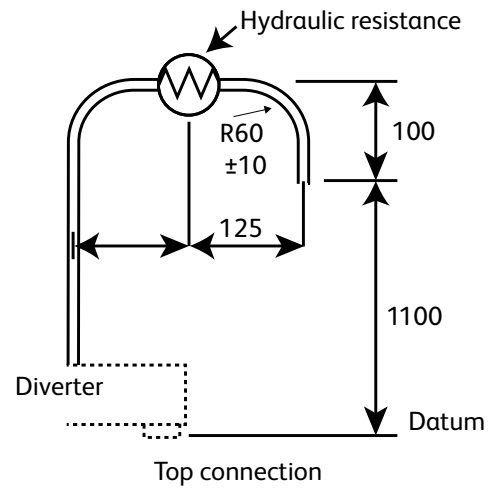

Figure 3 Hydraulic resistance for low pressure diverters with automatic return

## Chapter 6

# Durability

## 6.1 Durability of on/off (flow) control

### 6.1.1 General

Thermostatic mixing valves certified as complying with either BS EN 1111:1999 or BS EN 1287:1999 will be regarded as complying with the requirements of this specification for the durability of the on/off (flow) control. In all other cases the following tests shall be applied to mixing valves with an on/off (flow) control.

#### Note

The tests described here reproduce almost exactly the text of the ENs referred to.

### 6.1.2 Principle

This consists of subjecting the flow control devices to a specific number of opening and closing movements under specified hot and cold water conditions at the pressure and temperature specified.

### 6.1.3 Apparatus

A suitable test rig for operating the devices in line with their normal function.

The speed of operation of the control devices is to be set at 60°/s angular velocity (that is, 0.017s per degree of angle). For linear movement the velocity shall be 0.04 m/s.

#### Note

Due to the diversity of product design and especially for single sequential control thermostatic mixing valves, it will be necessary for the test house and manufacturer to liaise to produce a valid test apparatus and agree detailed test specifications.

### 6.1.4 Procedure

- Connect the thermostatic mixing valve to a suitable test apparatus designed to operate the on-off devices to within 90– 95 % of their intended travel.
- Supply hot water at a temperature of  $65 \pm 2^\circ\text{C}$  and cold water at a maximum of  $30^\circ\text{C}$  to the mixing valve under test.
- With the thermostatic mixing valve open, adjust the water pressure of the two supply circuits to the appropriate value for the designation given in [Table 5](#) and with the exception of single sequential thermostatic mixing valves set the temperature control device to a mean temperature position of  $38^\circ\text{C}$ .
- Subject the thermostatic mixing valve to 50,000 on/off cycles.



Abbreviated designation	Water pressure (bar)
All -LP-	1 Max
All -HP-	4 ± 0.2

Table 5 Supply pressures for durability tests

### 6.1.5 Requirements

During the test no failure of any component part shall occur.

Verify the leaktightness of the thermostatic mixing valve by the application of the tests given in [clauses 5.4 to 5.6](#).

## 6.2 Durability of diverters

### 6.2.1 General

Thermostatic mixing valves certified as complying with either BS EN 1111:1999 or BS EN 1287:1999 will be regarded as complying with the requirements of this specification for the durability of the diverter. In all other cases the following tests shall be applied to mixing valves with a diverter.

#### Note

The tests described here reproduce almost exactly the text of the ENs referred to.

This clause specifies two methods of test for the mechanical endurance of diverters of thermostatic mixing valves: one for manual diverters and one for diverters with automatic return and gives the corresponding specifications.

### 6.2.2 Principle

The principle of the test is to subject the diverter to a specified number of operations, with the thermostatic mixing valve being supplied alternately with cold water, and with hot water at  $65 \pm 2^\circ\text{C}$  (thermal shocks), in order to test its behaviour over a period of time, taking into account temperature.

### 6.2.3 Apparatus

#### 6.2.3.1 Manual diverter

- Automatic machine ensuring alternating movement of the diverter at a rate of  $15 \pm 1$  returns per minute.
- Supply circuits comprising a pump or a similar device by means of which the required static pressure can be obtained for cold water at  $<30^\circ\text{C}$  and hot water at  $65 \pm 2^\circ\text{C}$ .



### 6.2.3.2 Diverter with automatic return

- Mechanism for moving the diverter to the shower/shower head position under the conditions defined in **clause 5.8**.
- Supply circuits identical to those defined in **clause 6.2.3.1** but also comprising an automatic quick action valve to cut off the supply to the thermostatic mixing valve under test.

## 6.2.4 Procedure

### 6.2.4.1 Manual diverter

- Mount the thermostatic mixing valve, as supplied, on to the machine and connect both inlets to the supply circuits.
- Connect the drive device to the diverter lever by means of a flexible component.
- With the thermostatic mixing valve closed, adjust the water pressure on the two supply circuits to the appropriate value for the designation given in **Table 5**.
- With the temperature control device set to the full hot position adjust the flow rate to between 4 L/min and 6 L/min at the highest flowing outlet. This flow adjustment shall be made by means of the independently operating on/off (flow) control or, in the absence of this device, by partially obstructing the outlet.
- Subject the diverter to an endurance test of 30,000 cycles, each cycle comprising a return movement between the extreme positions. Note, if the diverter mechanism controls the on/off function of the valve then the mechanism needs to undertake 50,000 operations in accordance with **clause 6.1.4**.
- Throughout the test, supply the thermostatic mixing valve alternately at both inlets with cold water for 15 min ± 30 s then hot water for 15 min ± 30 s.
- Throughout the test, record any incidence of leaks, deformations, fracture etc.
- After 30,000 cycles, check the leaktightness of the diverter as defined in **clause 5.7**.

### 6.2.4.2 Diverters with automatic return

- Fit to the shower outlet the hydraulic resistance identified in **Table 4** appropriate to the designation.
- Mount the thermostatic mixing valve as supplied on to a support and connect both inlets to the supply circuits.
- With the thermostatic mixing valve closed, adjust the water pressure on the two supply circuits to the appropriate value for the designation given in **Table 5**.





- With the temperature control device set to the full hot position adjust the flow rate to a value that just permits proper operation of the diverter. This flow adjustment shall be made by means of the independently operating on/off (flow) control, or in the absence of this device by partially obstructing the outlet.
- Subject the diverter to an endurance test of 30,000 cycles, one cycle being defined as follows:
  - With the diverter in the “flow to bath” position, allow a flow of water for  $5 \pm 0.2$  s through the spout.
  - Move the diverter to the “flow to shower” position and allow a flow of water for  $5 \pm 0.2$  s.
  - Cut off the supply to the thermostatic mixing valve by means of the quick-acting valve; allow the diverter to return to the “flow to bath” position; then reopen the supply.
- Throughout the test, supply the thermostatic mixing valve alternately at both inlets with cold water for  $15 \text{ min} \pm 30 \text{ s}$  then hot water for  $15 \text{ min} \pm 30 \text{ s}$ .
- Throughout the test, record any incidence of leaks, deformations, fractures etc.
- After 30,000 cycles, check the leaktightness of the diverter as defined in [clause 5.8](#).

### 6.2.5 Requirements

During the test, no deformation, component fracture, blockage of the mechanism, leakage from the nozzle or shower/shower head or the diverter control joint shall be noted.

At the end of the test, check the leaktightness:

- in the conditions specified in [clause 5.7](#) for manual diverters;
- in the conditions specified in [clause 5.8](#) for diverters with automatic return.

## 6.3 Durability of thermostat

### 6.3.1 General

The durability of the thermostat shall be verified by means of the test described in [clause 6.3.3](#). The test shall be conducted on one of the three samples referred to in [Chapter 4](#) before it is subjected to the tests in [Chapter 7](#).

When the thermostatic mixing valve is suitable for more than one application, the durability of the thermostat need only be verified for the designation which represents the highest operating pressure range, the highest flow rate and the highest mixed water temperature setting of the applicable designations.

The durability cycling shall be carried out using the apparatus described in [Annex A](#).

If the test rig is supplied with recycled water, this shall not deteriorate in quality during the test and shall remain free of grease, debris etc.

### 6.3.2 Purpose

The purpose of the test is:

- a. to subject the thermostat to an accelerated cycle of operations which is representative of the normal operating conditions;
- b. to precondition one sample before carrying out the performance tests described in [Chapter 7](#).

#### Note

The most common exercise for the thermostat is in responding to a draw-off after a period of non-use (see [clause 7.5](#)). The durability cycle represents a large number of these responses, which are unlikely to be able to exceed 25 per day, as cooling to ambient temperature would not then be achieved. Periodic thermal shut-offs are called for at a rate equivalent to about one every three months (2500 cycles).

### 6.3.3 Procedure

6.3.3.1 Connect the mixing valve to the test rig (see [Annex A](#)).

6.3.3.2 Set the flow rate and mixed water temperature in accordance with [Table 6](#), with the water supply pressures and temperatures specified in that table. For mixing valves intended for single-point use, and having an integral atmospheric discharge nozzle, the flow rate may be adjusted by means of the mixing valve's integral flow control. In all cases the flow rate may be adjusted by means of either the tap 6 (see [Figure A.1 in Annex A](#)) in the discharge pipework (where used) or a throttling device, such as an orifice plate, fitted to the atmospheric discharge.

If technical information about tap 6 is required, please contact BuildCert/NSF ([www.buildcert.com](http://www.buildcert.com)).

6.3.3.3 Having obtained the required settings, provision must be made to prevent the setting of the mixed water temperature and flow rate from being disturbed.

6.3.3.4 Check that the timings given in [clause A.1.2.3](#) are achieved and record the mixed water temperature; then start the cyclic operation of the rig.



6.3.3.5 At intervals of  $2500 \pm 100$  cycles, implement the sequence specified in [clause A.1.2.3\(d\)](#).

6.3.3.6 At intervals of not more than 5000 cycles, check that the water supply pressures and temperatures and the mixed water flow rate are within the limits specified in [Table 6](#) for initial setting. Re-adjust, if necessary, the water supply pressures, temperatures and the mixed water flow rate to the values specified in [Table 6](#) for checking. The setting of the mixed water temperature control shall not be interfered with unless, after adjustment of the other parameters, the mixed water temperature is more than 1.5 K removed from the actual initial setting. Record the values of all parameters.

	Hot supply		Cold supply		Mixed water	
	Flow pressure (bar)	Temp. (°C)	Flow pressure (bar)	Temp. (°C)	Flow (L/min)	Temp. (°C)
Initial setting	Within operating pressure range (see Table 1)	$60 \pm 5$	Equal to hot supply pressure $\pm 10\%$	$15 \pm 5$	$\geq 0.5$ of available flow rate at applied flow pressure	As <a href="#">Table 9</a>
For checking	Initial setting $\pm 10\%$	Initial setting $\pm 1$ K	Equal to hot supply pressure $\pm 10\%$	Initial setting $\pm 1$ K	Initial setting $\pm 10\%$	Initial setting $\pm 2$ K

*Table 6 Settings for thermostat durability test*

6.3.3.7 On completion of  $30,000 \pm 200$  cycles, stop the test and service the mixing valve in accordance with the manufacturer’s instructions. After this, subject the valve to the performance tests of [Chapter 7](#).

### 6.3.4 Requirements

6.3.4.1 The mixed water temperature shall remain within the limits specified in [Table 6](#). When the operating conditions are checked and adjusted as specified in [clause 6.3.3.6](#), the mixed water temperature, before any readjustment, shall not be more than 2 K removed from the actual initial setting.

6.3.4.2 On completion of the durability cycling, the valve shall satisfy all of the performance requirements specified in [Chapter 7](#).



## Chapter 7

# Performance

## 7.1 General

Performance requirements shall be verified by means of the tests described in this specification. The tests are laboratory type tests. The requirements shall be satisfied by each of the samples referred to in **Chapter 4**. The thermal performance requirements of each sample are summarised in **Table 15** at the end of this chapter.

If for any reason the designed function of a TMV prevents the normal test methodology from being utilised, then the designed function must be no less effective.

The applicable performance tests described in **clauses 7.3 to 7.12** shall be carried out in the sequence specified in **clause 7.2** using the apparatus described in **Annex B**. The mixing valve shall be installed and commissioned on the test rig in accordance with the manufacturer's instructions. The applicability of some of the tests is determined by the configuration of the controls of the thermostatic mixing valve, and the following exemptions apply:

- a. Mixing valves without a diverter are exempt from the test in **clause 7.5**.
- b. Mixing valves in which two applications are not served by two separately operating mechanisms sharing common supply connections are exempt from the test in **clause 7.6**.
- c. Mixing valves with no user-accessible adjustment of the mixed water temperature are exempt from the test in **clause 7.8**.
- d. Mixing valves with single sequential control and integral atmospheric discharge are exempt from the test in **clause 7.12**.
- e. Mixing valves having a flow rate less than 4.5 L/min when tested in accordance with **clause 7.3** are exempt from the test in **clause 7.12**.

Throughout the performance tests described in **clauses 7.3 to 7.12**, the water supply flow pressures and water supply temperatures shall be maintained within the setting limits specified.

Additional safety features built into the design of the thermostatic mixing valves that preclude testing exactly to the requirements of the performance requirements of D 08 will not be penalised if the valve delivers water at a safe temperature as prescribed by this standard.



## 7.2 Sequence of tests

- f. Flow rate and sensitivity of temperature control – see [clause 7.3](#).
- g. Initial setting for thermal performance tests – see [clause 7.4](#).
- h. Mixed water temperature overshoot on operation of diverter (manual or automatic return) – see [clause 7.5](#).
- i. Mixed water temperature overshoot on operation of second outlet – see [clause 7.6](#).
- j. Mixed water temperature overshoot on starting from ambient – see [clause 7.7](#).
- k. Mixed water temperature overshoot on adjustment of mixed water temperature – see [clause 7.8](#).
- l. Thermal shut-off – see [clause 7.9](#).
- m. Stability of mixed water temperature with changing supply pressure – see [clause 7.10](#).
- n. Stability of mixed water temperature with changing supply temperature – see [clause 7.11](#).
- o. Stability of mixed water temperature at reduced flow rate – see [clause 7.12](#).

## 7.3 Flow rate and sensitivity of temperature control

### 7.3.1 Purpose

The purpose of the test is to determine:

- a. the flow rate of mixed water;
- b. the ease with which the mixed water temperature can be adjusted to the correct value for the intended application.

If a thermostatic mixing valve is suitable for more than one application, this test can be conducted for all of these in a single test if the user adjustment range for mixed water temperature can be set to provide all of the required mixed water temperatures in one setting. Valves suitable for bath use may need to be tested separately as larger inlets are usually provided for bath fill valves.

Thermostatic mixing valves that do not have a conventional temperature control lever for adjusting the mixed water temperature (that is, no angular or linear movement) should be tested and should comply with the requirements of [Annex G](#).



### 7.3.2 Procedure

7.3.2.1 Connect the mixing valve to the test rig (see [Annex B](#)).

7.3.2.2 Fully open any integral flow control. Where outlet pipework is required, also open fully the valve 5 and the tap 6. Ensure that the bleed valves 8 are closed (see [Figure B.1](#)).

7.3.2.3 For mixing valves with user adjustment of the mixed water temperature, adjust the maximum mixed water temperature stop so that the full range of mixed water temperatures required in this test is available. For mixing valves with a preset temperature, access the mixed water temperature adjustment.

7.3.2.4 With the pressure losses and supply temperatures specified in [Table 8](#), set the temperature control/adjustment to give a mixed water temperature equal to the first setting specified in [Table 7](#). Where outlet pipework is required, adjust the tap 6 ([Figure B.1](#)) to give the required pressure loss.

7.3.2.5 Measure and record the mixed water flow rate and temperature, and record the position of the temperature control/adjustment. Where outlet pipework is required, record the outlet pressure.

Setting	Mixed water temperature (°C)	Comments
1	$T_{a-5}^{-3}$	-
2	$T_a \pm 1$	-
3	$T_{a+5}^{+3}$	-
4	lesser of $T_{a+9}^{+7}$ and $T_{b+3}^{+1}$	Only if actual setting $3 < T_b + 1$
5	$T_{b+3}^{+1}$	Only if actual setting $4 < T_b + 1$
<b>Note:</b> $T_a$ = lowest maximum mixed water temperature specified in Table 2 for the applications to be covered. $T_b$ = highest maximum mixed water temperature specified in Table 2 for the applications to be covered.		

Table 7 Mixed water temperature settings for determination of flow rate and sensitivity



Abbreviated designation	Hot supply		Cold supply		Mixed water
	Flow pressure (bar)	Temp. (°C)	Flow pressure (bar)	Temp. (°C)	Flow (L/min)
-HP-B -HP-S -HP-W -HP, D44, D46 (shower)	1.0 ± 0.05	57 ± 1	1.0 ± 0.05	15 ± 1	≥8
Above designations with suffix E	1.0 ± 0.05	57 ± 1	1.0 ± 0.05	15 ± 1	<8
-HP, T44, T46 -HP, D44, D46 (bath fill)	1.0 ± 0.05	57 ± 1	1.0 ± 0.05	15 ± 1	≥15
-LP-B -LP-S -LP-W -LP, D44, D46 (shower)	0.2 ± 0.01	57 ± 1	0.2 ± 0.01	15 ± 1	≥8
Above designations with suffix E	0.2 ± 0.01	57 ± 1	0.2 ± 0.01	15 ± 1	<8
-LP, T44, T46 -LP, D44, D46 (bath fill)		57 ± 1	0.2 ± 0.01	15 ± 1	≥15

Table 8 Flow rates

7.3.2.6 Set the temperature control/adjustment, maintaining the pressure loss and supply temperatures, to give each of the mixed water temperatures specified in [Table 7](#). At each setting measure and record the mixed water flow rate and temperature, and record the position of the temperature control. Where outlet pipework is required, record the outlet pressure.

### 7.3.3 Expression of results

Record the flow rates and the sensitivity of the temperature adjustment.

### 7.3.4 Requirements

7.3.4.1 The flow rate shall at no point be less than the value specified in [Table 8](#) for the designation of valve, except that for those with suffix E the flow rate shall be less than 8 L/min.

7.3.4.2 The sensitivity of the temperature control/adjustment shall be at least 5 degrees angular per K or, in the case of a lever, at least 4 mm per K.



## 7.4 Initial settings for thermal performance tests

### Purpose

The purpose of the settings is to establish, at the commencement of the test sequence, a representative mixed water temperature and flow rate appropriate to the application, with the supply pressures at a mid-value in the operating range.

### 7.4.1 Settings

7.4.1.1 The initial settings for each designation (see [Chapter 8](#)) shall be in accordance with [Table 9](#). These settings shall not be altered or further adjusted during any thermal performance test procedure, except where specified; for example, after initial setting the flow rate shall not be readjusted except in [clause 7.12](#).

7.4.1.2 For mixing valves intended for single-point use, and having an integral atmospheric discharge nozzle, the flow rate shall be adjusted by means of the mixing valve's integral flow control, but if the mixing valve has a sequential control the flow rate cannot be adjusted independently of the temperature and therefore the flow rate will be that resulting at the set temperature. In all other cases the flow rate shall be adjusted by means of the tap 6 in the discharge pipework. This adjustment shall be made with any integral flow control fully open.

7.4.1.1 For mixing valves having a user-adjustable mixed water temperature, the mixed water temperature setting given in [Table 9](#) shall be the maximum available. Having obtained the required settings, the means provided by the manufacturer for limiting the maximum mixed water temperature, locking the mixed water temperature adjustment, or otherwise rendering the adjustment tamper-proof, shall be utilised. Further adjustment of the mixed water temperature during the sequence of tests for a particular designation is not allowed.

### Note

The outlet pressure is not measured in the thermal performance tests and so the measuring line may be closed.





Abbreviated designation	Hot supply		Cold supply		Mixed water	
	Flow pressure (bar)	Temp. (°C)	Flow pressure (bar)	Temp. (°C)	Flow (L/min)	Temp. (°C)
-HP-B	3.0 ± 0.1	57 ± 1	3.0 ± 0.1	15 ± 1	9.0 ± 0.5	38 <sup>-0</sup> <sub>-2</sub>
-HP-BE	3.0 ± 0.1	57 ± 1	3.0 ± 0.1	15 ± 1	† Q <sub>s</sub> ± 0.5	38 <sup>-0</sup> <sub>-2</sub>
-LP-B	0.6 ± 0.02	57 ± 1	0.6 ± 0.02	15 ± 1	9.0 ± 0.5	38 <sup>-0</sup> <sub>-2</sub>
-LP-BE	0.6 ± 0.02	57 ± 1	0.6 ± 0.02	15 ± 1	† Q <sub>s</sub> ± 0.5	38 <sup>-0</sup> <sub>-2</sub>
-HP-S -HP-W	3.0 ± 0.1	57 ± 1	3.0 ± 0.1	15 ± 1	9.0 ± 0.5	41 <sup>-0</sup> <sub>-2</sub>
-HP-SE -HP-WE	3.0 ± 0.1	57 ± 1	3.0 ± 0.1	15 ± 1	† Q <sub>s</sub> ± 0.5	41 <sup>-0</sup> <sub>-2</sub>
-LP-S -LP-W	0.6 ± 0.02	57 ± 1	0.6 ± 0.02	15 ± 1	9.0 ± 0.5	41 <sup>-0</sup> <sub>-2</sub>
-LP-SE -LP-WE	0.6 ± 0.02	57 ± 1	0.6 ± 0.02	15 ± 1	† Q <sub>s</sub> ± 0.5	41 <sup>-0</sup> <sub>-2</sub>
-HP, D44, D46	3.0 ± 0.1	57 ± 1	3.0 ± 0.1	15 ± 1	See Note 2	
-HP-T44	3.0 ± 0.1	57 ± 1	3.0 ± 0.1	15 ± 1	20 ± 1	44 <sup>-0</sup> <sub>-2</sub>
-HP-T46	3.0 ± 0.1	57 ± 1	3.0 ± 0.1	15 ± 1	20 ± 1	46 <sup>-0</sup> <sub>-2</sub>
-LP, D44, D46	0.6 ± 0.02	57 ± 1	0.6 ± 0.02	15 ± 1	See Note 2	
-LP-T44	0.6 ± 0.02	57 ± 1	0.6 ± 0.02	15 ± 1	20 ± 1	44 <sup>-0</sup> <sub>-2</sub>
-LP-T46	0.6 ± 0.02	57 ± 1	0.6 ± 0.02	15 ± 1	20 ± 1	46 <sup>-0</sup> <sub>-2</sub>

† Q<sub>s</sub> = lowest flow rate recorded in [clause 7.3.3](#).

**Note 1:** If the specified flow rate is not achievable, then the available flow rate shall be used and recorded.

**Note 2:** For designations D44, D46 the initial settings above are those appropriate to the outlet being tested, e.g. for HP-D44 use HP-T44 for the bath outlet, and HP-S for the shower outlet.

Table 9 Initial settings for thermal performance tests



## 7.5 Mixed water temperature overshoot on operation of diverter (manual or automatic return)

### 7.5.1 Purpose

The purpose of the test is to determine the characteristic of any transient rise in the mixed water temperature, which may occur when the mixed water flow is diverted from one outlet to another.

### 7.5.2 Procedure

7.5.2.1 Connect the mixing valve to the test rig and adjust the mixed water temperature and flow rate at each outlet to the initial setting given in [Table 9](#) for the appropriate designation.

7.5.2.2 Operate the diverter to the shower position; allow mixed water to flow for  $120 \pm 5$  s and then measure and record the mixed water temperature.

7.5.2.3 Return the diverter to the bath position. Allow mixed water to flow for  $120 \pm 5$  s and then measure and record the mixed water temperature.

#### Note

It may be necessary to repeat the steps in [clauses 7.5.2.2 and 7.5.2.3](#) to ensure stable operation of the valve and constant values of the bath and shower temperatures.

7.5.2.4 By hand and as fast as possible, operate the diverter to the shower position.

7.5.2.5 Monitor and record the mixed water temperature until it has stabilised.

7.5.2.6 In the case of diverters with automatic return, close the flow control of the mixing valve. In the case of manual diverters, allow the mixed water to flow for a further  $120 \pm 5$  s and then, by hand and as fast as possible, operate the diverter to the bath position.

7.5.2.7 Monitor and record the mixed water temperature until it has stabilised.

7.5.2.8 Repeat the procedure to give three sets of results for each test specimen.

### 7.5.3 Expression of results

Assess the temperature transient obtained during the steps in [clauses 7.5.2.5 and 7.5.2.7](#) to determine the duration at or above each 1 K temperature rise shown in [Table 10](#) for the appropriate application. Refer transient temperature rises to the mixed water temperature appropriate to the outlet.

### 7.5.4 Requirement

7.5.4.1 The average duration of the transient temperature rise at or above each 1 K temperature rise given in [Table 10](#) for the appropriate application shall be not greater than the values given in [Table 10](#). Individual test results shall not exceed the permitted duration by more than 10%.



7.5.4.2 No steady mixed water temperature after stabilisation shall differ from the actual initial setting of the outlet concerned by more than 2 K.

## 7.6 Mixed water temperature overshoot on operation of second outlet

### 7.6.1 Principle

The purpose of the test is to determine the characteristics of any transient mixed water temperature rise which may occur during the operation of the second outlet of a valve having two separately operating thermostatically controlled outlet mechanisms and sharing a common inlet.

### 7.6.2 Procedure

7.6.2.1 Connect the mixing valve to the test rig and adjust the mixed water temperature and flow rate at each outlet separately to the appropriate initial setting given that for that application in [Table 9](#). Set the lowest temperature application first and then the highest.

#### Note

Ensure that the other outlet is closed when setting each initial condition.



Rise in mixed water temperature from actual initial setting (K)			Duration (s)	Reference (see Note) (°C)		
Bidet Shower Washbasin	Bath fill up to 44°C	Bath fill up to 46°C		Bidet	Shower Washbasin	Bath fill
+2	+4	+2	10 or more	40	43	48
+3	+5	+3	6.30	41	44	49
+4	+6	+4	4.00	42	45	50
+5	+7	+5	2.50	43	46	51
+6	+8	+6	1.90	44	47	52
+7	+9	+7	1.20	45	48	53
+8	+10	+8	0.75	46	49	54
+9	+11	+9	0.50	47	50	55
+10	+12	+10	0.25	48	51	56

**Note:**  
This temperature is the value corresponding to the permitted temperature rise above the maximum set mixed water temperature.

Table 10: Permitted duration of transient mixed water temperature rise

7.6.2.2 After a stabilisation period of not less than 120 s, ensure that the initial conditions are still within the requirements of **Table 9** for that application and record these values.

7.6.2.3 Within 120 s of recording the values in **clause 7.6.2.2** for the highest temperature application, rapidly open, by hand and as fast as possible, the outlet appropriate to the lowest temperature application whilst monitoring the mixed water temperature at both outlets. When both mixed water temperatures have stabilised, cease monitoring.

7.6.2.4 Within 120 s of the cessation of monitoring in **clause 7.6.2.3**, rapidly close, by hand and as fast as possible, the outlet appropriate to the highest temperature application whilst monitoring the mixed water temperature at the other outlet. When the outlet temperature has stabilised, cease monitoring.

7.6.2.5 Within 120 s of the cessation of monitoring in **clause 7.6.2.4**, rapidly open, by hand and as fast as possible, the outlet appropriate to the highest temperature application whilst monitoring the mixed water temperature at both outlets. When both mixed water temperatures have stabilised, cease monitoring.



7.6.2.6 Within 120 s of the cessation of monitoring in [clause 7.6.2.5](#), rapidly close, by hand and as fast as possible, the outlet appropriate to the lowest temperature application whilst monitoring the mixed water temperature at the other outlet. When the outlet temperature has stabilised, cease monitoring.

7.6.2.7 Repeat the procedure to give three sets of results for each test specimen.

### 7.6.3 Expression of results

Assess the temperature transients obtained during [clauses 7.6.2.3–7.6.2.6](#) to determine the duration of any temperature rise above the initial conditions recorded in [clause 7.6.2.2](#) in accordance with the values shown in [Table 10](#) for the appropriate application temperature.

### 7.6.4 Requirement

7.6.4.1 The average duration of any transient temperature rise for the appropriate application shall be not greater than the values given in [Table 10](#). Individual test results shall not exceed the permitted duration by more than 10%.

7.6.4.2 No steady mixed water temperature after stabilisation shall differ from the actual initial setting of the outlet concerned by more than 2 K.

## 7.7 Mixed water temperature overshoot on starting from ambient

### 7.7.1 Purpose

The purpose of the test is to determine the characteristic of any transient rise in the mixed water temperature which may occur when water is drawn off after a prolonged period of non-use.

#### Note

Over a period of several hours, the installed mixing valve will cool to ambient temperature. This commonly results in the thermostat adjusting the valve mechanism to fully open the hot water port, and thereby shut off the cold water port. Subsequently, as water is drawn off, the thermostat must respond quickly to limit the temperature of mixed water as hot water flows into the valve.

### 7.7.2 Procedure

7.7.2.1 Connect the mixing valve to the test rig (see [Annex B](#)).

7.7.2.2 Starting from the initial setting (see [Table 9](#)), allow mixed water to flow for 2 min ± 5 s and then measure and record the mixed water temperature.

7.7.2.3 Close off the hot and cold water supply valves and open the valve 7 in the cross-over pipe (see [Figure B.1](#)). Supply both inlets with cold water at a temperature of 20 ± 1°C at a total flow rate at least equal to half the set flow rate in [Table 9](#).



7.7.2.4 After 5 min  $\pm$  15 s close off the mixed water flow. In the case of mixing valves intended for single point use, and having an integral atmospheric discharge nozzle, this shall be achieved by closing the integral flow control. In all other cases close the valve 5 (see [Figure B.1](#)) in the discharge pipework.

7.7.2.5 Close the valve 7 and restore the hot and cold water supplies, opening the bleed valves 8 until the set supply temperatures are regained. Ensure that the flow pressures will be the same as before.

7.7.2.6 For mixing valves intended for single-point use, and having an integral atmospheric discharge nozzle, rapidly open, by hand and as fast as possible, the integral flow control to the same position it was in to achieve the initial setting. In all other cases rapidly open, by hand and as fast as possible, the valve 5 in the discharge pipework.

7.7.2.7 Monitor and record the mixed water temperature.

7.7.2.8 Repeat the procedure to give three sets of results for each sample.

### 7.7.3 Expression of results

The temperature transient obtained shall be assessed to determine the duration at or above each 1 K temperature rise shown in [Table 10](#) for the appropriate designation. For the three test results on each sample, calculate the average duration at each temperature rise. Transient temperature rises shall be referred to the mixed water temperature existing at the start of each of the three tests.

#### Note

An example of the assessment of test results is given in [Annex E](#).

### 7.7.4 Requirements

7.7.4.1 The average duration of the transient temperature rise at or above each 1 K temperature rise shown in [Table 10](#) for the appropriate designation shall not be longer than the values in [Table 10](#). Individual test results shall not exceed the permitted duration by more than 10%.

7.7.4.2 For each result the final mixed water temperature shall not differ from the actual initial setting of the sample concerned by more than 2 K.

## 7.8 Mixed water temperature overshoot on adjustment of mixed water temperature

### 7.8.1 Purpose

The purpose of the test is to determine, for thermostatic mixing valves having a user-adjustable mixed water temperature setting, the characteristic of any transient rise in the mixed water temperature which may occur when the mixed water temperature setting is suddenly changed from a cool setting to the maximum setting.



## 7.8.2 Procedure

7.8.2.1 Connect the mixing valve to the test rig (see [Annex B](#)).

7.8.2.2 Starting from the initial setting (see [Table 9](#)), allow mixed water to flow for  $2 \text{ min} \pm 5 \text{ s}$  and then measure and record the mixed water temperature.

7.8.2.3 Adjust the position of the temperature control to give a mixed water temperature of  $30 \pm 1^\circ\text{C}$  (or, if the lowest temperature available is greater than this, then to the lowest temperature available.)

7.8.2.4 After  $3 \text{ min} \pm 15 \text{ s}$  rapidly adjust, by hand and as fast as possible, the temperature control to the maximum temperature stop.

7.8.2.5 Monitor and record the mixed water temperature.

7.8.2.6 Repeat the procedure to give three sets of results for each sample.

## 7.8.3 Expression of results

The temperature transient obtained shall be assessed to determine the duration at or above each 1 K temperature rise shown in [Table 10](#) for the appropriate designation. For the three test results on each sample calculate the average duration at each temperature rise. Transient temperature rises shall be referred to the mixed water temperature existing at the start of each of the three tests.

### Note

An example of the assessment of test results is given in [Annex E](#).

## 7.8.4 Requirements

7.8.4.1 The average duration of the transient temperature rise at or above each 1 K temperature rise shown in [Table 10](#) for the appropriate designation shall not be longer than the values in [Table 10](#). Individual test results shall not exceed the permitted duration by more than 10%.

7.8.4.2 For each result the final mixed water temperature shall not differ from the actual initial setting of the sample concerned by more than 2 K.



## 7.9 Thermal shut-off

### 7.9.1 Purpose

The purpose of the test is to determine the following:

7.9.1.1 In the event of complete and sudden failure of the cold water supply:

- a. the characteristic of any transient rise in the mixed water temperature which may occur;
- b. the maximum rise in mixed water temperature resulting from prolonging the supply failure.

7.9.1.2 In the event of complete and sudden restoration of the cold water supply following a supply failure:

- a. the characteristic of any transient rise in the mixed water temperature that may occur;
- b. the steady temperature to which the mixed water returns.

7.9.1.3 In the event of complete and sudden failure of the hot water supply:

That the flow rate decays rapidly to an acceptable leakage rate, or the rate of reduction in mixed water temperature is not excessive.

7.9.1.4 In the event of complete and sudden restoration of the hot water supply following a supply failure:

- a. the characteristic of any transient rise in the mixed water temperature that may occur;
- b. the steady temperature to which the mixed water returns.

### 7.9.2 Procedure

7.9.2.1 Connect the mixing valve to the test rig (see [Annex B](#)).

7.9.2.2 Starting from the initial setting, isolate any branched take-offs in the cold water supply line, including the cold water pressure measuring line. Also isolate the outlet pressure measuring line, if open.

7.9.2.3 Instantaneously isolate the cold water supply and continuously monitor the mixed water temperature.

7.9.2.4 Leave the cold water supply isolated for 15 min ± 30 s and then instantaneously restore the cold water, ensuring that the flow pressure will be the same as before. Continue to monitor the mixed water temperature.

7.9.2.5 Reconnect the cold water pressure measuring line and, if necessary, readjust the flow pressures. Record the mixed water temperature.





- 7.9.2.6 Isolate any branched take-offs in the hot water supply line, including the hot water pressure measuring line. Also isolate the outlet pressure measuring line, if open.
- 7.9.2.7 Instantaneously isolate the hot water supply and simultaneously commence collection of the mixed water discharge. Continuously monitor the mixed water temperature. After  $5 \pm 0.5$  s, commence collection of the mixed water discharge in a separate vessel. The second collection period shall be for  $30 \pm 0.5$  s. The collected volumes may be taken as the time-integrated output of a rate of flow meter provided that the response time of the meter is taken into account.
- 7.9.2.8 Leave the hot water supply isolated for  $5 \text{ min} \pm 15 \text{ s}$  and then instantaneously restore the hot water supply, ensuring that the flow pressure will be the same as before, and monitor the mixed water temperature.
- 7.9.2.9 Reconnect the hot water pressure measuring line and, if necessary, readjust the flow pressures. Record the mixed water temperature.
- 7.9.2.10 Repeat the procedure to give three sets of results for each sample.

### 7.9.3 Expression of results

- 7.9.3.1 The temperature transient obtained for each cold water isolation, for each cold water restoration, and for each hot water restoration shall be assessed to determine the duration at or above each 1 K temperature rise shown in [Table 10](#) for the appropriate designation. For the three results of each of these tests calculate the average duration at each temperature rise. Transient temperature rises shall be referred to the mixed water temperature existing at the start of each of the three tests.

#### Note

An example of the assessment of test results is given in [Annex E](#).

- 7.9.3.2 For the three test results for hot water isolation determine the average volume of water collected in the first 5 s after isolation of the hot water supply and also the average volume of water collected in the subsequent 30 s. Determine the minimum temperature of mixed water during the first 5 s after isolation.

### 7.9.4 Requirements

- 7.9.4.1 For cold water isolation and restoration, and for hot water restoration the average duration of the transient temperature rise at or above each 1 K temperature rise shown in [Table 10](#) for the appropriate designation shall not be longer than the values in [Table 10](#). Individual test results shall not exceed the permitted duration by more than 10%. If the water discharges in a cycle (that is, increasing in flow until the valve reacts and flow stops), then each of these transient events shall for the appropriate designation comply with the requirements detailed in [Table 10](#).
- 7.9.4.2 For each result the final mixed water temperature, after restoration of the cold water supply and after restoration of the hot water supply, shall not differ from the actual initial setting of the sample concerned by more than 2 K.



7.9.4.3 For hot water isolation:

- a. During the first 5 seconds after hot water isolation either the average volume of water discharged shall not exceed the appropriate values given in **Table 11** or, if this is exceeded, the average reduction in mixed water temperature shall not exceed the appropriate values given in **Table 11**. Individual test results shall not exceed the permitted volume by more than 10% or the permitted temperature reduction by more than 0.5 K.
- b. During the subsequent 30 s the average volume of water discharged shall not exceed the appropriate values given in **Table 11**. Individual test results shall not exceed the permitted volume by more than 10%.

Application	During first 5 s after hot water isolation		During 5–35 s after hot water isolation
	Reduction in mixed water temperature from actual initial setting (K)	Discharge (L)	Discharge (L)
Bidet	3	0.25	0.75
Shower Washbasin	6	0.25	0.75
Bath fill up to 44°C	9	0.5	1.5
Bath fill up to 46°C	11	0.5	1.5

Table 11 Leakage flow of cold water

## 7.10 Temperature stability with changing water supply pressure

### 7.10.1 Purpose

The purpose of the test is to determine:

- a. the change in mixed water temperature when one supply pressure is varied over the whole operating pressure range whilst the other supply pressure remains constant;
- b. the change in mixed water temperature when one supply pressure is reduced to a very low value whilst the other supply pressure remains constant;

#### Note

This represents an extreme supply starvation condition

- c. the steady temperature to which the mixed water returns when supply pressure is restored.



### **7.10.2 Procedure**

7.10.2.1 Connect the mixing valve to the test rig (see [Annex B](#)).

7.10.2.2 Starting from the initial setting, slowly adjust the cold water supply pressure in steps to the values shown in [Table 12](#).

7.10.2.3 Measure and record the mixed water temperature after each pressure change.

7.10.2.4 With the initial setting regained, slowly adjust the hot water supply pressure in steps to the values shown in [Table 12](#).

7.10.2.5 Measure and record the mixed water temperature after each pressure change.

7.10.2.6 Repeat the procedure to give three sets of results for each sample.

### **7.10.3 Expression of results**

7.10.3.1 For the three test results calculate, for each numbered pressure change, the average change in mixed water temperature from the actual initial setting.

### **7.10.4 Requirements**

7.10.4.1 After each change in supply pressure, the average change in mixed water temperature from the actual initial setting of the sample concerned shall not be greater than the values given in [Table 12](#). Individual test results shall not exceed the permitted temperature change by more than 0.5 K.



	Supply pressure (bar)		Permitted change in mixed water temperature from actual initial setting (K)			
	All -HP	All -LP	Bidet	Shower Washbasin	Bath fill up to 44°C	Bath fill up to 46°C
First change	2 ± 0.1	0.4 ± 0.02	+2/-3	+2/-6	+2/-9	+2/-11
Second change	1 ± 0.05	0.2 ± 0.01	+2/-3	+2/-6	+2/-9	+2/-11
Third change*	0.5 ± 0.02	0.1 ± 0.005	3	+3/-6	+3/-9	+3/-11
Fourth change initial	3 ± 0.1	0.6 ± 0.02	2	2	2	2
Fifth change	5 ± 0.2	1 ± 0.05	+2/-3	+2/-6	+2/-9	+2/-11
Sixth change initial	3 ± 0.1	0.6 ± 0.02	2	2	2	2

\* This represents a condition outside the supply conditions for normal use.

Table 12 Changes in water supply pressure and permitted temperature change

## 7.11 Temperature stability with changing water supply temperature

### 7.11.1 Purpose

The purpose of the test is to determine:

- the change in mixed water temperature when one supply temperature is varied over the whole operating temperature range whilst the other supply remains constant;
- the steady temperature to which the mixed water returns when the supply temperature is restored.

### 7.11.2 Procedure

7.11.2.1 Connect the mixing valve to the test rig (see [Annex B](#)).

7.11.2.2 Starting from the initial setting, adjust the cold water supply temperature to the values given in [Table 13](#). Dwell at each cold water temperature for more than 2 min.

7.11.2.3 Record the mixed water temperature 2 min ± 5 s after each temperature change.



7.11.2.4 Starting from the initial setting, adjust the hot water supply temperature to the values given in **Table 13**. Dwell at each hot water temperature for more than 2 min.

7.11.2.5 Record the mixed water temperature 2 min  $\pm$  5 s after each temperature change.

### 7.11.3 Requirements

7.11.3.1 After each change in supply temperature, the change in mixed water temperature from the actual initial setting of the sample concerned shall not be greater than the values in **Table 13**.

## 7.12 Temperature stability at reduced flow rate

### 7.12.1 Purpose

The purpose of the test is to determine, for thermostatic mixing valves having a set flow rate according to **Table 9** greater than the appropriate value in **Table 14**:

- a. the change in mixed water temperature when the flow rate is reduced to a low value with unequal supply pressures;
- b. the steady temperature to which the mixed water returns when the flow rate and supply pressures are restored.

### 7.12.2 Procedure

7.12.2.1 Connect the mixing valve to the test rig (see **Annex B**).

7.12.2.2 Starting from the initial setting, reduce the cold water supply pressure to between 80% and 85% of the set flow pressure.

7.12.2.3 Slowly reduce flow rate to the appropriate value specified in **Table 14** maintaining the flow pressures. If the mixing valve incorporates an integral flow control which allows the flow rate to be adjusted independent of the temperature, then this control shall be used to reduce the flow rate. Otherwise the flow rate shall be reduced by means of the tap 6 (see **Figure B.1**).

7.12.2.4 Measure and record the mixed water temperature after the above procedure.



	Supply temperature (°C)		Permitted temp. change (K)
	Hot water	Cold water	
First change	Actual initial setting minus $5 \pm 1$ K	Actual initial setting minus $8 \pm 1$ K	2
Second change	Actual initial setting plus $8 \pm 1$ K	Actual initial setting plus $5 \pm 1$ K	2
Third change	Actual initial setting $\pm 1$ K	Actual initial setting $\pm 1$ K	2

Table 13 Changes in water supply temperature and permitted temperature change

Application	Reduced flow rate (L/min)	Permitted temp. change (K)
Bidet, shower, washbasin	$4 \pm 0.1$	2
Bath fill	$10 \pm 0.2$	2

Table 14 Reduced flow rates and permitted temperature change

- 7.12.2.5 Restore the cold water supply pressure to the initial setting and then return the flow rate to the initial set value.
- 7.12.2.6 Measure and record the mixed water temperature.
- 7.12.2.7 Having regained the initial setting, reduce the hot water supply pressure to between 80% and 85% of the set flow pressure.
- 7.12.2.8 Slowly reduce flow rate to the appropriate value specified in **Table 14** maintaining the flow pressures and using the same control as in **clause 7.10.2.3**.
- 7.12.2.9 Measure and record the mixed water temperature after the above procedure.
- 7.12.2.10 Restore the hot water supply pressure to the initial setting and then return the flow rate to the initial set value.
- 7.12.2.11 Measure and record the mixed water temperature.
- 7.12.2.12 Repeat the procedure to give three sets of results for each sample



### **7.12.3 Expression of results**

- 7.12.3.1 For the three test results of flow reduction with hot pressure greater than cold calculate the average change in mixed water temperature from the actual initial setting.
- 7.12.3.2 For the three test results of flow reduction with cold pressure greater than hot, calculate the average change in mixed water temperature from the actual initial setting.

### **7.12.4 Requirements**

- 7.12.4.1 After the reduction in flow rate, the average change in mixed water temperature from the actual initial setting of the sample concerned shall not be greater than the values given in **Table 14**. Individual test results shall not exceed the permitted temperature change by more than 0.5 K.
- 7.12.4.2 After restoration of the supply pressures and flow rate to the initial setting the average change in mixed water temperature from the actual initial setting of the sample concerned shall not be greater than 2 K. Individual test results shall not exceed 2.5 K.

The thermal performance requirements of each sample referred to in **Chapter 4** are summarised in **Table 15** on the following pages.



Clause No.	Value	Run 1	Run 2	Run 3	Requirement
7.5.2.2	Shower initial	$T_0$	$T_2$	$T_4$	$T_0$ as <b>Table 9</b>
7.5.2.3	Bath initial	$T_1$	$T_3$	$T_5$	$T_1$ as <b>Table 9</b>
7.5.2.5	Shower transient	$\delta T_0$	$\delta T_2$	$\delta T_4$	Av. $\{\delta T_0, \delta T_2, \delta T_4\}$ as <b>Table 10</b>
	Shower final	$T_2$	$T_4$	$T_6$	$T_2, T_4, T_6$ each = $T_0 \pm 2$
7.5.2.7	Bath transient	$\delta T_1$	$\delta T_3$	$\delta T_5$	Av. $\{\delta T_1, \delta T_3, \delta T_5\}$ as <b>Table 10</b>
	Bath final	$T_3$	$T_5$	$T_7$	$T_3, T_5, T_7$ each = $T_1 \pm 2$
7.6.2.2	Lower initial	$T_0$	$T_6$	$T_{12}$	$T_0$ as <b>Table 9</b>
	Higher initial	$T_1$	$T_7$	$T_{13}$	$T_1$ as <b>Table 9</b>
7.6.2.3	Lower transient	$\delta T_0$	$\delta T_6$	$\delta T_{12}$	Av. $\{\delta T_0, \delta T_6, \delta T_{12}\}$ as <b>Table 10</b>
	Higher transient	$\delta T_1$	$\delta T_7$	$\delta T_{13}$	Av. $\{\delta T_1, \delta T_7, \delta T_{13}\}$ as <b>Table 10</b>
	Lower final	$T_2$	$T_8$	$T_{14}$	$T_2, T_8, T_{14}$ each = $T_0 \pm 2$
	Higher final	$T_3$	$T_9$	$T_{15}$	$T_3, T_9, T_{15}$ each = $T_1 \pm 2$
7.6.2.4	Lower transient	$\delta T_2$	$\delta T_8$	$\delta T_{14}$	Av. $\{\delta T_2, \delta T_8, \delta T_{14}\}$ as <b>Table 10</b>
	Lower final	$T_4$	$T_{10}$	$T_{16}$	$T_4, T_{10}, T_{16}$ each = $T_0 \pm 2$
	Lower transient	$\delta T_4$	$\delta T_{10}$	$\delta T_{16}$	Av. $\{\delta T_4, \delta T_{10}, \delta T_{16}\}$ as <b>Table 10</b>
	Higher transient	$\delta T_3$	$\delta T_9$	$\delta T_{15}$	Av. $\{\delta T_3, \delta T_9, \delta T_{15}\}$ as <b>Table 10</b>
	Lower final	$T_6$	$T_{12}$	$T_{18}$	$T_6, T_{12}, T_{18}$ each = $T_0 \pm 2$
	Higher final	$T_5$	$T_{11}$	$T_{17}$	$T_5, T_{11}, T_{17}$ each = $T_1 \pm 2$
7.6.2.6	Higher transient	$\delta T_5$	$\delta T_{11}$	$\delta T_{17}$	Av. $\{\delta T_5, \delta T_{11}, \delta T_{17}\}$ as <b>Table 10</b>
	Higher final	$T_7$	$T_{13}$	$T_{19}$	$T_7, T_{13}, T_{19}$ each = $T_1 \pm 2$
7.7.2.3	Initial	$T_0$	$T_1$	$T_2$	$T_0$ as <b>Table 9</b>
7.7.2.7	Transient	$\delta T_0$	$\delta T_1$	$\delta T_2$	Av. $\{\delta T_0, \delta T_1, \delta T_2\}$ as <b>Table 10</b>
	Final	$T_1$	$T_2$	$T_3$	$T_1, T_2, T_3$ each = $T_0 \pm 2$
7.8.2.2	Initial	$T_0$	$T_1$	$T_2$	$T_0$ as <b>Table 9</b>
7.8.2.5	Transient	$\delta T_0$	$\delta T_1$	$\delta T_2$	Av. $\{\delta T_0, \delta T_1, \delta T_2\}$ as <b>Table 10</b>
	Final	$T_1$	$T_2$	$T_3$	$T_1, T_2, T_3$ each = $T_0 \pm 2$
7.9.2.2	Initial	$T_0$	$T_2$	$T_4$	$T_0$ as <b>Table 9</b>
7.9.2.3	Transient	$\delta T_0$	$\delta T_2$	$\delta T_4$	Av. $\{\delta T_0, \delta T_2, \delta T_4\}$ as <b>Table 10</b>
7.9.2.4	Transient	$\delta T_0$	$\delta T_2$	$\delta T_4$	Av. $\{\delta T_0, \delta T_2, \delta T_4\}$ as <b>Table 10</b>
7.9.2.5	Final	$T_1$	$T_3$	$T_5$	$T_1, T_3, T_5$ each = $T_0 \pm 2$





Clause No.	Value	Run 1	Run 2	Run 3	Requirement
(7.9.2.7)	(Minimum)	$(\delta T_1)$	$(\delta T_3)$	$(\delta T_5)$	$(Av. \{\delta T_1, \delta T_3, \delta T_5\})$ as <b>Table 11</b>
7.9.2.8	Transient	$\delta T_1$	$\delta T_3$	$\delta T_5$	$Av. \{\delta T_1, \delta T_3, \delta T_5\}$ as <b>Table 10</b>
7.9.2.9	Final	$T_2$	$T_4$	$T_6$	$T_2, T_4, T_6$ each = $T_0 \pm 2$
7.10.2.2	Initial	$T_0$	$T_{12}$	$T_{24}$	$T_0$ as <b>Table 9</b>
7.10.2.3	Change 1	$T_1$	$T_{13}$	$T_{25}$	$Av. \{(T_1 - T_0), (T_{13} - T_0), (T_{25} - T_0)\}$ as <b>Table 12</b>
	Change 2	$T_2$	$T_{14}$	$T_{26}$	$Av. \{(T_2 - T_0), (T_{14} - T_0), (T_{26} - T_0)\}$ as <b>Table 12</b>
	Change 3	$T_3$	$T_{15}$	$T_{27}$	$Av. \{(T_3 - T_0), (T_{15} - T_0), (T_{27} - T_0)\}$ as <b>Table 12</b>
	Change 4	$T_4$	$T_{16}$	$T_{28}$	$Av. \{(T_4 - T_0), (T_{16} - T_0), (T_{28} - T_0)\}$ as <b>Table 12</b>
	Change 5	$T_5$	$T_{17}$	$T_{29}$	$Av. \{(T_5 - T_0), (T_{17} - T_0), (T_{29} - T_0)\}$ as <b>Table 12</b>
	Change 6	$T_6$	$T_{18}$	$T_{30}$	$Av. \{(T_6 - T_0), (T_{18} - T_0), (T_{30} - T_0)\}$ as <b>Table 12</b>
7.10.2.5	Change 1	$T_7$	$T_{19}$	$T_{31}$	$Av. \{(T_7 - T_0), (T_{19} - T_0), (T_{31} - T_0)\}$ as <b>Table 12</b>
	Change 2	$T_8$	$T_{20}$	$T_{32}$	$Av. \{(T_8 - T_0), (T_{20} - T_0), (T_{32} - T_0)\}$ as <b>Table 12</b>
	Change 3	$T_9$	$T_{21}$	$T_{33}$	$Av. \{(T_9 - T_0), (T_{21} - T_0), (T_{33} - T_0)\}$ as <b>Table 12</b>
	Change 4	$T_{10}$	$T_{22}$	$T_{34}$	$Av. \{(T_{10} - T_0), (T_{22} - T_0), (T_{34} - T_0)\}$ as <b>Table 12</b>
	Change 5	$T_{11}$	$T_{23}$	$T_{35}$	$Av. \{(T_{11} - T_0), (T_{23} - T_0), (T_{35} - T_0)\}$ as <b>Table 12</b>
	Change 6	$T_{12}$	$T_{24}$	$T_{36}$	$Av. \{(T_{12} - T_0), (T_{24} - T_0), (T_{36} - T_0)\}$ as <b>Table 12</b>
7.11.2.2	Initial	$T_0$	-	-	$T_0$ as <b>Table 9</b>
7.11.2.3	Change 1	$T_1$	-	-	$(T_1 - T_0)$ as <b>Table 13</b>
	Change 2	$T_2$	-	-	$(T_2 - T_0)$ as <b>Table 13</b>
	Change 3	$T_3$	-	-	$(T_3 - T_0)$ as <b>Table 13</b>
7.11.2.4	Initial	$T_0$	-	-	$(T - T_0)$ as <b>Table 9</b>
7.11.2.5	Change 1	$T_1$	-	-	$(T_1 - T_0)$ as <b>Table 13</b>
	Change 2	$T_2$	-	-	$(T_2 - T_0)$ as <b>Table 13</b>
	Change 3	$T_3$	-	-	$(T_3 - T_0)$ as <b>Table 13</b>
7.12.2.2	Initial	$T_0$	$T_4$	$T_8$	$T_0$ as <b>Table 9</b>
7.12.2.4	Low flow	$T_1$	$T_5$	$T_9$	$Av. \{(T_1 - T_0), (T_5 - T_0), (T_9 - T_0)\}$ as <b>Table 14</b>
7.12.2.6	Final	$T_2$	$T_6$	$T_{10}$	$Av. \{(T_2 - T_0), (T_6 - T_0), (T_{10} - T_0)\}$ as <b>Table 14</b>
7.12.2.9	Low flow	$T_3$	$T_7$	$T_{11}$	$Av. \{(T_3 - T_0), (T_7 - T_0), (T_{11} - T_0)\}$ as <b>Table 14</b>
7.12.2.11	Final	$T_4$	$T_8$	$T_{12}$	$Av. \{(T_4 - T_0), (T_8 - T_0), (T_{12} - T_0)\}$ as <b>Table 14</b>

Table 15 Summary of thermal performance requirements for each sample

## Chapter 8

## Designation

Thermostatic mixing valves complying with this specification are designated by:

- a. the intended operating pressure range;
- b. the intended application.

The last element of the designation codes is given in **Table 16**. In every case this element shall be preceded by “*Thermostatic mixing valve-DH Performance Specification D 08*”. Elsewhere in this specification, for brevity, the last element only is quoted and is referred to as “Abbreviated designation”.

Where a thermostatic mixing valve is suitable for more than one application, the code can include the final element of each application: for example, “*Thermostatic mixing valve-DH Performance Specification D 08 -LP-B/S/W*” would be suitable for bidet, shower, or washbasin applications in the low operating pressure range.

Where, for reasons of water economy, a flow rate less than 8 L/min is required for the application, thermostatic mixing valves of -B,-S, and -W designations having a flow rate less than 8 L/min when tested according to **clause 7.3** shall carry the designation suffix E.

Code	Operating pressure range	Application
-HP-B	High pressure	Bidet
-HP-S	High pressure	Shower
-HP-W	High pressure	Washbasin
-HP-T44	High pressure	Bath with fill temperature up to 44°C
-HP-T46	High pressure	Bath with fill temperature up to 46°C
-HP-D44	High pressure	Bath (up to 44°C fill) and shower (up to 41°C)
-HP-D46	High pressure	Bath (up to 46°C fill) and shower (up to 41°C)
-LP-B	Low pressure	Bidet
-LP-S	Low pressure	Shower
-LP-W	Low pressure	Washbasin
-LP-T44	Low pressure	Bath with fill temperature up to 44°C
-LP-T46	Low pressure	Bath with fill temperature up to 46°C
-LP-D44	Low pressure	Bath (up to 44°C fill) and shower (up to 41°C)
-LP-D46	Low pressure	Bath (up to 46°C fill) and shower (up to 41°C)

Table 16 Designation codes

## Chapter 9

# Marking

Thermostatic mixing valves complying with this specification shall be permanently and legibly marked on the product with the manufacturer's name or identification mark and unique model reference, sufficient to enable the designation of the product to be compared with the corresponding information on any certificate of compliance with this specification. Where the marking is applied to a detachable part of the valve (for example a cap or index), this detachable part shall be attached to the valve by means of a fixing that requires a tool, other than a standard screwdriver, to remove the part.

### Note

The durability of the marking should be such that it is unlikely to be removed by normal operation and maintenance. The marking should be positioned so that it can be readily identified.

The unique identification cannot be located:

- where disconnection of the hot and cold pipework is required to verify the product by its unique identification mark;
- on the water supply pipe;
- in such a position that it requires isolation of the water supply and disassembly to verify the product by its unique identification mark.



## Chapter 10

# Installation and operating instructions

The manufacturer shall provide installation, operating and maintenance instructions. These shall include:

- a. information on the designation of the thermostatic mixing valve concerned (see **Chapter 8**);
- b. information on the commissioning and routine in-service tests to be performed as described in **Chapter 11**;
- c. information on the frequency of in-service tests and service work as described in **Annex F**;
- d. information on the need for any anti-backsiphonage devices (for example check valves) required to be installed with the mixing valve together with the specification of such devices. This specification shall be sufficient to enable the combination of mixing valve and anti-backsiphonage devices tested in accordance with this specification to be replicated on site;
- e. the need for the inclusion of any isolating valves etc to enable on-site tests to be made;
- f. details of suitable outlet fittings (for example draw-off taps etc).



## Chapter 11

# Commissioning and in-service tests

## 11.1 Commissioning

### 11.1.1 Purpose

11.1.1.1 Commissioning ensures that the TMV and the water supplies to it are appropriate and that the valve has been adjusted to provide a mixed water at an appropriate temperature for the intended application of use. It also provides records of the thermal performance of the TMV.

For information, the type-testing detailed in previous clauses in D 08 are not applicable for on-site testing.

### 11.1.2 Commissioning procedure

11.1.2.1 Check that the TMV is appropriate for the application of use (see [Table 17](#)).

Check that the water supplies are appropriate for the installation of the TMV (see [Table 18](#) and Stage 1 ([Figure 4](#))).

Check that the mixed water temperature is appropriate for the application; if required, adjust the mixed water temperature up to a maximum application temperature (as indicated in [Table 17](#)) in accordance with the manufacturer's instructions.

#### Note

After risk assessment a temperature that is lower than the maximum temperature allowable for the designated installation (vulnerable people) can also be set if deemed appropriate to do so.

Check that the supply pipework is free from debris or detritus.

11.1.2.2 Carry out the following commissioning test sequence (see Stage 2 ([Figure 5](#))):

- a. Record the temperature of the hot and cold water supplies adjacent to the TMV. Record the pressures of the hot and cold water supplies at the inlets of the TMV.

#### Note

If this measurement is not possible at the inlets to the TMV and is taken elsewhere, then the pressures at the TMV will be lower than the measured values.

- b. For all outlets, measure the temperature of the mixed water at the maximum available flow and record.
- c. Isolate the cold water supply to the mixing valve and observe the mixed water outlet.

11.1.2.3 If there is a flow stream after 5 s then collect any water discharging into a suitably graduated measuring vessel for 60 s; if the volume of water collected is greater than 120 ml then further investigation is needed.

11.1.2.4 If there is no flow or if the volume of water collected is less than or equal to 120 ml, then restore the cold water supply; after 15 s record the mixed water temperature.

Application and designation	Initial set temperature of the mixed water (at point of discharge)
Bidet (B)	38°C max
Shower (S)	41°C max
Washbasin (W)	41°C max
Bath (44°C fill) (T44)	44°C max
Bath (46°C fill) (T46)	46°C max
Diverter Bath/Shower (D44)	Bath fill 44°C max, Shower 41°C max
Diverter Bath/Shower (D46)	Bath fill 46°C max, Shower 41°C max

**Note:** Set the mixed water outlet at these maximum initial temperature settings. During the cold water restoration stage the mixed water temperature can deviate by 2°C from these maximum initial settings.

Table 17 Mixed water temperature

Operating range	High pressure use	Low pressure use
Maximum static pressure	10 bar	
Flow pressure, hot and cold	1 to 5 bar	0.2 to 1 bar
Hot supply temperature	Minimum 55°C	
Cold supply temperature	Maximum 20°C	

Table 18 Conditions for normal use

11.1.2.5 Verify that this temperature does not differ by more than 2°C from the temperature taken in **11.1.2.2 (b)** (this is a restoration test after a failure of the cold water supply and some deviation of the mixed water outlet temperature may be expected).

11.1.2.6 If the mixed water temperature differs by more than 2°C from the set temperature taken at **11.1.2.2 (b)**, then recheck the supply conditions or recommission (see **paragraph 11.1.2.7**).

11.1.2.7 The valve must then be adjusted and recommissioned in accordance with the manufacturer's instructions.

#### Note

Consider checking the following:

- the supply conditions for normal use are within the conditions specified in **Table 18**;
- the in-line or integral strainers and check valves are clean;
- any isolating valves are fully open;
- the TMV installation has been undertaken in accordance with the manufacturer's instructions;
- the temperature differential of the TMV is appropriate for the supply conditions, in accordance with the manufacturer's instructions;
- the designation of use of the TMV matches the intended application.

## 11.2 In-service test

### 11.2.1 Purpose

The purpose of in-service testing is to maintain assured performance and to provide records of the thermal performance of the TMV, all of which should be consistent with this document and the risk assessment carried out by the Water Safety Group.

### 11.2.2 In-service test procedure

11.2.2.1 Carry out the following in-service test sequence (see Stage 3 (**Figure 6**)):

- a. For all outlets, measure and record the temperature of the mixed water at the maximum available flow. If required, the mixed water temperature may be readjusted up to a maximum temperature as indicated in **Table 17**.

**Note**

After risk assessment, a temperature that is lower than the maximum temperature allowable for the designated installation (vulnerable people) can also be set if deemed appropriate to do so.

b. Isolate the cold water supply to the mixing valve and observe the mixed water outlet.

11.2.2.2 If there is a flow stream after 5 s then collect any water discharging into a suitably graduated measuring vessel for 60 s; if the volume of water collected is greater than 120 ml, then recommissioning or service work is needed.

11.2.2.3 If there is no flow or if the volume of water collected is less than or equal to 120 ml, then restore the cold water supply; after 15 s record the mixed water temperature.

11.2.2.4 Verify that this temperature does not differ by more than 2°C from the temperature taken in [11.2.2.1\(a\)](#) (this is a restoration test after a failure of the cold water supply and some deviation of the mixed water outlet temperature may be expected).

11.2.2.5 If the mixed water temperature differs by more than 2°C from the set temperature taken at [11.2.2.1\(a\)](#), then recheck the supply conditions or recommission (see [paragraph 11.2.2.6](#)).

11.2.2.6 The valve must then be readjusted and recommissioned in accordance with the manufacturer's instructions.



11

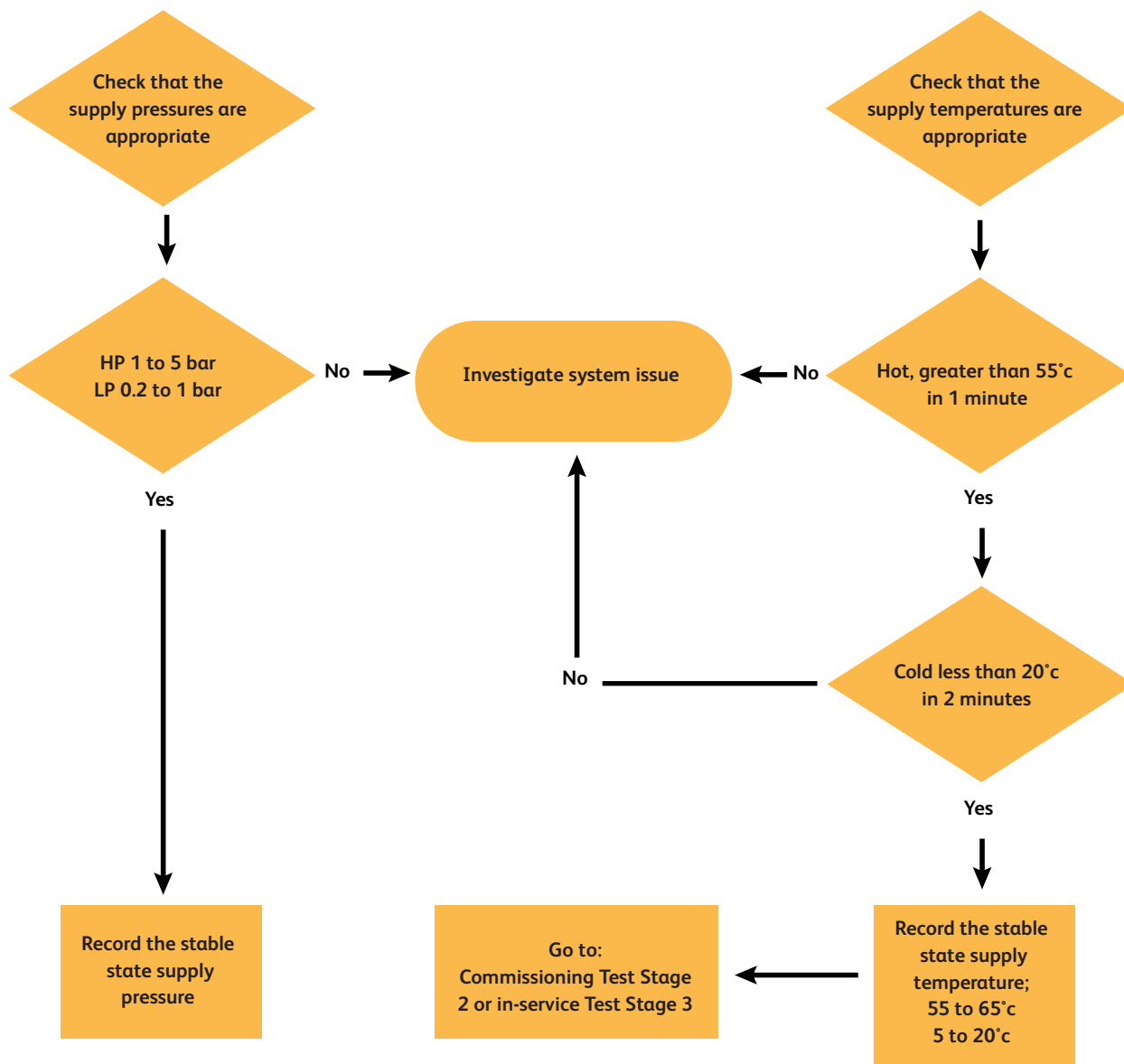

Figure 4 Stage 1:WHTM -04-01 confirmation of supply conditions

11

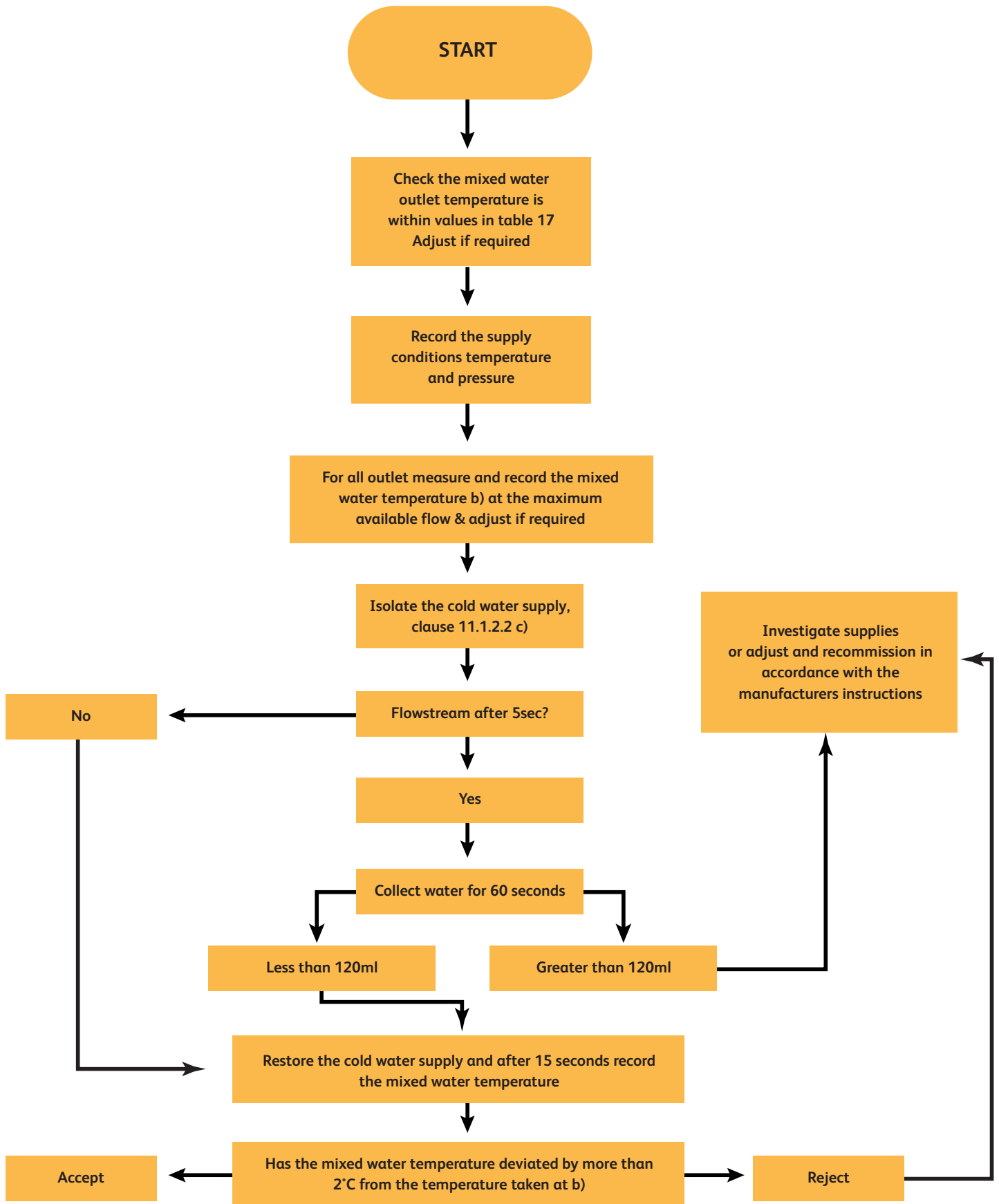

Figure 5 Stage 2: Commissioning procedure

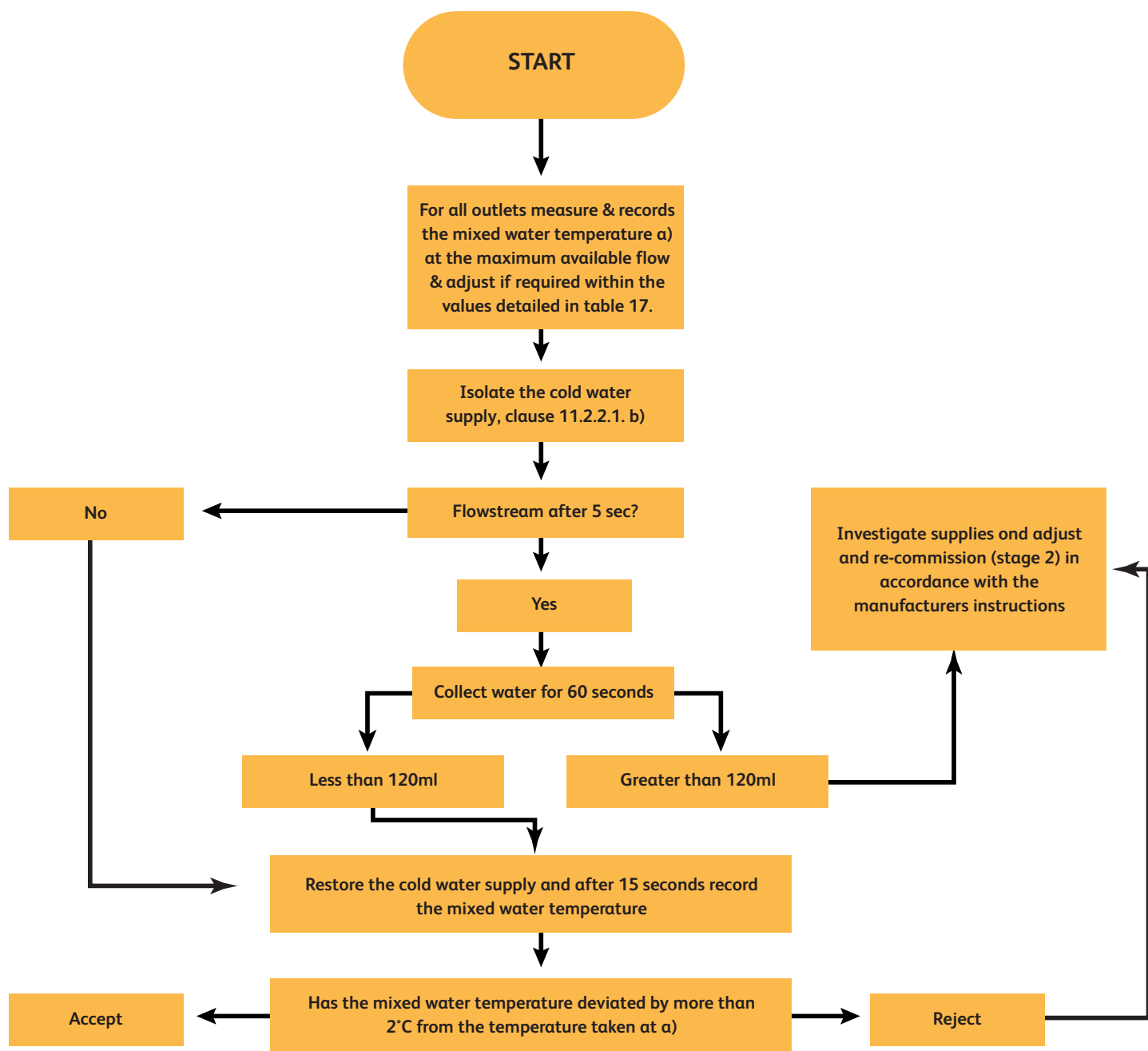

Figure 6 Stage 3: In-service test procedure



## TMV record sheet

### Test date:

Valve reference		Location	
Blend setting	°C	Installation date	
Outlet type Bath/washbasin/shower		Maintenance frequency	
Min temp. diff for the valve	°C	Maintenance frequency	
Engineer's name:		Maintenance date:	

### Supply conditions:

Date	Previous supply conditions	Service detail	Current supply conditions
	°C	Hot supply temperature	°C
	°C	Cold supply temperature	°C
	bar	Hot supply pressure	bar
	bar	Cold supply pressure	bar
	°C	Stable mixed water outlet temperature	°C
	°C	Temperature differential	°C

Non-compliance with WHTM-04-01. Remedial actions required are as follows:



**Commissioning and in-service test results (clauses 11.1 or 11.2)**

Test Detail	Result	Observation/comment
Mixed water outlet temperature at maximum flow (X)	°C	
Mixed water outlet temperature at 50 % flow	°C	
Isolate the cold water supply – flow after 5 s?	Yes/No	
Volume of water in 60 s if flow after 5 s*	mL	
Mixed water outlet temperature after water supply restored	°C	
Deviation from the initial result X Greater than 2°C**	°C Yes/No	
Deviation from the previous in-service result Greater than 1°C	°C Yes/No	
Strainers/check valves clean?	Yes/No	
Isolation valves fully open?	Yes/No	
Final mixed water outlet temperature	°C	

\*If the volume is more than 120 mL, reset the valve according to manufacturers’ instructions and retest.

\*\*If yes, then reset the valve according to manufacturers’ instructions and retest.

**Frequency of in-service test (Annex F)**

Next in-service test date:
----------------------------

AA

Annex A (normative):

## Apparatus for durability test on thermostat

### A.1 Test rig

#### A.1.1 General

The test rig shall comply with **Figure A.1** in respect of dimensions, equipment and general arrangement. However, some details will need to differ in order to suit particular mixing valves and water supply facilities.

If the test rig is supplied with recycled water, this shall not deteriorate in quality during the test and shall remain free of grease, debris etc.

#### A.1.2 Description

##### A.1.2.1 Inlets

The inlet pipework shall include:

- a. a quick acting shut-off valve (7 and 8) with remote actuation, such as a solenoid valve, in each supply;
- b. a flow meter (Q<sub>h</sub> and Q<sub>c</sub>). Alternatively, the mixed water flow rate may be measured by determining the volume of discharge collected in a known time;
- c. provision to accommodate a temperature measuring device ( $T_h$  and  $T_c$ );
- d. a branch to an arrangement for cross-connecting the supplies;
- e. a straight pipe 1, of the same nominal bore as the inlet connection of the mixing valve and of a length not greater than 260 mm between the temperature measuring device and the pressure take-off tee 4;
- f. a pressure take-off tee 4 complying with **Figure A.2** and **Table A.1** and of the same nominal size as the pipe 1;
- g. a pipe 2 of the same nominal bore as the inlet connection of the mixing valve under test and of a length not greater than 310 mm;

#### Note

Pipe elbows and other fittings supplied with the mixing valve are considered to be part of the mixing valve, not part of the test rig.



- h. an arrangement for cross-connecting the supplies through a branch containing valve 5. Valve 5 shall be of a quick-acting shut-off type with remote actuation such as a solenoid valve;
- i. lagging over the whole length of both inlet pipes between the temperature measuring device and the inlet connection of the mixing valve. This lagging shall be of mineral wool with a thickness of at least 25 mm, or of equivalent insulating value.

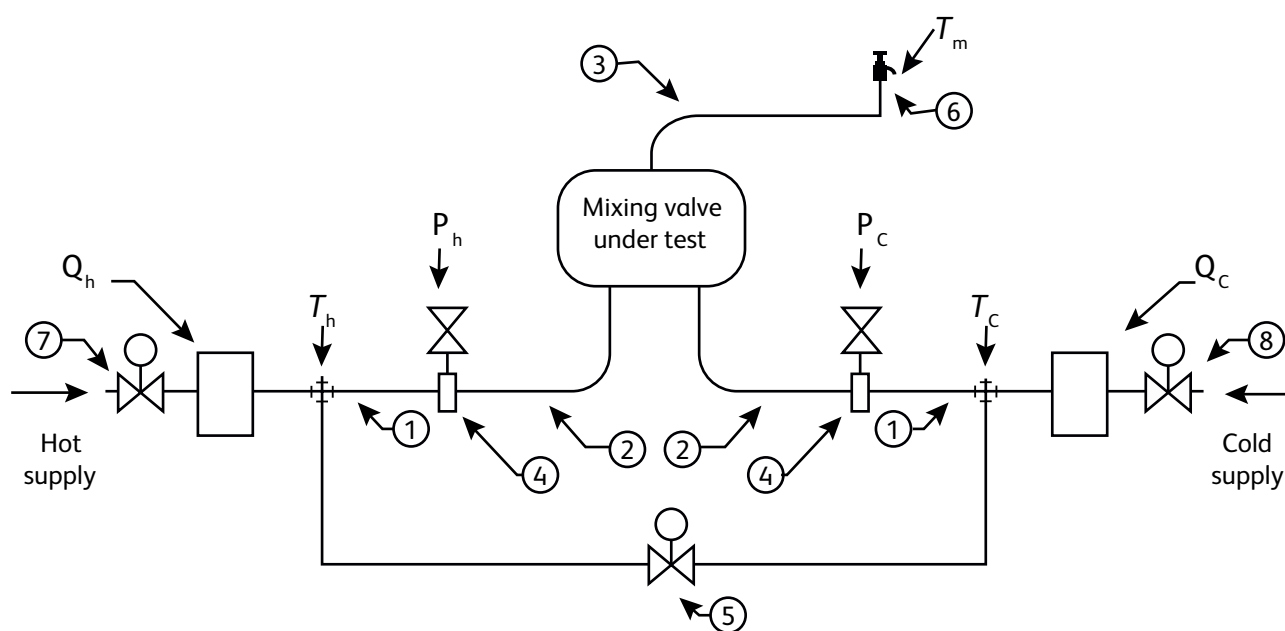
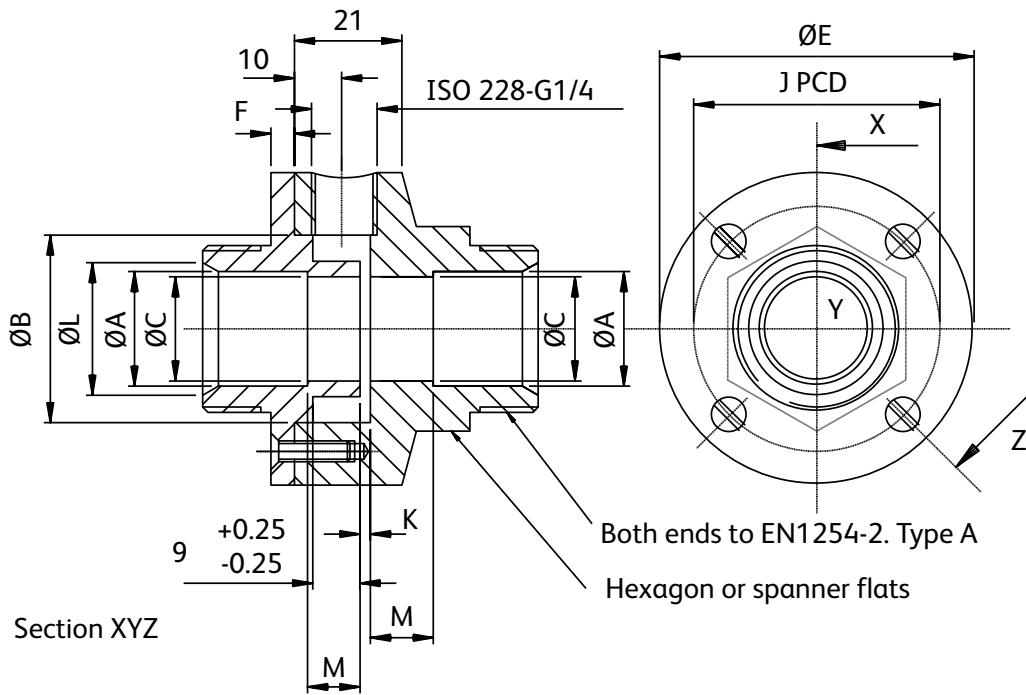

Figure A.1 Test rig for durability test on thermostat



Dimensions in millimetres

Note1: Unspecified tolerance  $\pm 1$

Note 2: Tube ends to be square, without burrs and inserted to full depth of dimension A

Figure A.2: Pressure take-off tee





Dimensions in millimetres				
DN	10	15	20	25
A	10.2 ± 0.05	15.2 ± 0.05	22.25 ± 0.05	28.25 ± 0.05
B	18.5 ± 0.5	25.5 ± 0.5	35.5 ± 0.5	46.5 ± 0.5
C	9 ± 0.05	13.85 ± 0.05	20.6 ± 0.1	26.6 ± 0.1
E	42	49	59	70
F	4	4	4	4
J	30	37	47	58
K	0.5 ± 0.1	0.6 ± 0.1	0.7 ± 0.1	0.9 ± 0.1
L	13.5 ± 0.5	18.5 ± 0.5	25.5 ± 0.5	32.5 ± 0.5
M	3	5.5	9	12
Size of screws	M4 × 15	M4 × 15	M4 × 15	M5 × 15
Number of screws	4	4	4	4

Table A.1 Dimensions of pressure take-off tees

#### A.1.2.2 Outlet

For mixing valves that do not have an integral atmospheric discharge nozzle, outlet pipework must be fitted. This shall have a total length between the mixing valve outlet connection and the inlet of the draw-off tap not greater than 610 mm and shall include:

- a. a draw-off tap 6 of the same nominal size as the pipe 3. The discharge nozzle of this tap shall be the highest point of the outlet;
- b. provision to accommodate a temperature measuring device ( $T_m$ ).

#### Note

Pipe elbows and other fittings supplied with the mixing valve are considered to be part of the mixing valve, not part of the test rig.



### A.1.2.3 Operating devices

The valves 5, 7 and 8 shall be operated by means of a timing device in a defined cycle:

- a. start with valves 7 and 8 open and valve 5 closed;
- b.  $10 \pm 1$  s after the rate of increase in the mixed water temperature has reduced to not more than 1 K/s (see [clause A.2.3.3](#)), close valve 7 and open valve 5;
- c.  $15 \pm 1$  s after the rate of decrease in the mixed water temperature has reduced to not more than 1 K/s (see [clause A.2.3.3](#)), revert to (a);
- d. at the frequency specified in [clause 6.3.3.5](#), when at stage (a), 20 s after the rate of increase in the mixed water temperature has reduced to not more than 1 K/s (see [clause A.2.3.3](#)), close valve 8. After a further 60 s, revert to (a).

## A.2 Measurement of parameters

### A.2.1 Pressure measurement

The flow pressures of the hot water supply,  $P_h$ , the cold water supply,  $P_c$ , and the mixed water,  $P_m$ , shall be measured with an accuracy of 1 %.

### A.2.2 Flow measurement

The flow rates of hot water,  $Q_h$ , and cold water,  $Q_c$ , shall be measured with an accuracy of 2 %. The flow rate of mixed water is the sum ( $Q_h + Q_c$ ). If the mixed water flow rate is determined by the collection method, the accuracy shall be 3 %.

### A.2.3 Temperature measurement

#### A.2.3.1 Mounting

The thermally sensitive part of sensing elements shall be fully immersed.

In the case of the mixed water temperature, the thermometer element shall be rigidly mounted in contact with the water outlet and arranged so that all discharges pass over or along the full extent of the thermally sensitive part of the element. The thermally sensitive part of the element shall be located in air 30–50 mm from the end of the outlet.

#### A.2.3.2 Accuracy

The temperature of the hot water supply,  $T_h$ , the cold water supply,  $T_c$ , and the mixed water,  $T_m$ , shall be measured with an accuracy of 0.5 K.

#### A.2.3.3 Rate of change

The rate of temperature change referred to in [clause A.1.2.3](#) shall be determined on the basis of the temperature change in each of two successive periods of 0.5 s.



Annex B (normative)

## Apparatus for performance tests

### B.1 Test rig

#### B.1.1 General

The test rig shall comply with **Figure B.1** in respect of dimensions, equipment and general arrangement. However, some details will need to differ in order to suit particular mixing valves and water supply facilities.

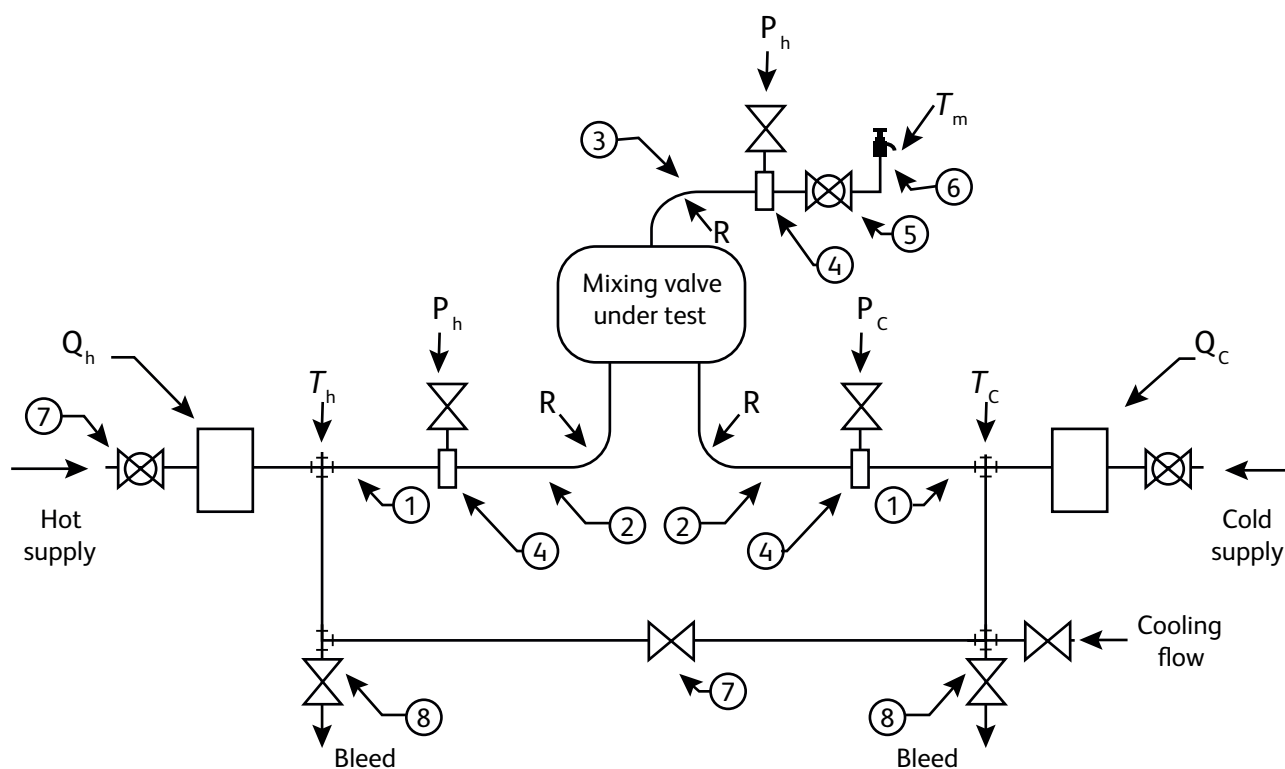

Figure B.1 Test rig for performance tests

#### B.1.2 Description

##### B.1.2.1 Inlets

The inlet pipework shall include:

- a. a quarter turn spherical plug valve in the supply pipe;
- b. a flow meter ( $Q_h$  and  $Q_c$ );

AB

### Note 1

Invalid readings of the flow meters will result if the bleed valve(s) 8 are open.

- c. provision to accommodate a temperature measuring device ( $T_h$  and  $T_c$ );
- d. a branch to bleed valve 8;
- e. a straight pipe 1, of the same nominal bore as the inlet connection of the mixing valve and of length  $250 \pm 10$  mm between the temperature measuring device and the pressure take-off tee 4;
- f. a pressure take-off tee 4 complying with [Figure A.2](#) and [Table A.1](#) and of the same nominal size as the pipe 1;
- g. a pipe 2 of the same nominal bore as the inlet connection of the mixing valve under test and of length  $300 \pm 10$  mm. Only bends of radius  $R \geq 4 \times$  the bore of the pipe are permitted in this pipe, and the bends shall not total more than  $90^\circ$ ;

### Note 2

Pipe elbows and other fittings supplied with the mixing valve are considered to be part of the mixing valve, not part of the test rig.

- h. an arrangement for cross-connecting the supplies through a branch containing valve 7 connected between the branches to bleed valves 8;
- i. lagging over the whole length of both inlet pipes between the temperature measuring device and the inlet connection of the mixing valve. This lagging shall be of mineral wool with a thickness of at least 25 mm, or of equivalent insulating value.

#### B.1.2.2 Outlet

For mixing valves that do not have an integral atmospheric discharge nozzle, outlet pipework must be fitted. This shall have a total length between the mixing valve outlet connection and the inlet of the draw-off tap of  $600 \pm 10$  mm and shall include:

- a. a pipe 3 between the mixing valve outlet connection and the pressure take-off tee 4. This pipe shall be of the same nominal bore as the outlet connection of the mixing valve under test and of length  $300 \pm 10$  mm. Only bends of radius  $R \geq 4 \times$  the bore of the pipe are permitted in this pipe, and the bends shall not total more than  $90^\circ$ ;

### Note

Pipe elbows and other fittings supplied with the mixing valve are considered to be part of the mixing valve, not part of the test rig.



- b. a pressure take-off tee 4 complying with [Figure A.2](#) and [Table A.1](#) and of the same nominal size as the pipe 3;
- c. a quarter turn spherical plug valve 5 of the same nominal size as the pipe 3;
- d. a draw-off tap 6 of the same nominal size as the pipe 3. The discharge nozzle of this tap shall be the highest point of the outlet provision to accommodate a temperature-measuring device ( $T_m$ ).

## B.2 Measurement of parameters

### B.2.1 Pressure measurement

The flow pressures of the hot water supply,  $P_h$ , the cold water supply,  $P_c$ , and the mixed water,  $P_m$ , shall be measured with an accuracy of 1%. The datum for pressure measurement shall be taken at the lowest point of the atmospheric end of the discharge nozzle of the tap 6, or the nozzle of the integral discharge spout etc.

### B.2.2 Flow measurement

The flow rates of hot water,  $Q_h$ , and cold water,  $Q_c$ , shall be measured with an accuracy of 2%. The flow rate of mixed water is the sum ( $Q_h + Q_c$ ).

### B.2.3 Temperature measurement

#### B.2.3.1 Mounting

The thermally sensitive part of sensing elements shall be fully immersed.

In the case of the mixed water temperature, the thermometer element shall be rigidly mounted in contact with the water outlet and arranged so that all discharges pass over or along the full extent of the thermally sensitive part of the element. The thermally sensitive part of the element shall be located in air 30–50 mm from the end of the outlet.

#### B.2.3.2 Accuracy

The temperature of the hot water supply,  $T_h$ , the cold water supply,  $T_c$ , and the mixed water,  $T_m$ , shall be measured with an accuracy of 0.2 K.

#### B.2.3.3 Response time

The mixed water temperature shall be measured with instrumentation having a total system response such that a change in reading equal to 90% of a step change is indicated in a time of  $0.3 \pm 0.05$  s. This response time shall be verified by means of the procedure specified in [Annex C](#).



**B.2.4 Angular position**

The angular position of the temperature control shall be measured with an accuracy of 0.5° angular. Linear movement shall be measured with an accuracy of 0.5 mm.

**B.2.5 Duration of transients**

Transient events shall be timed to an accuracy of 0.1 s.

AC

Annex C (normative)

## Determination of thermometer response time

### C.1 Purpose

The purpose is to determine the response time of the complete water-temperature-measuring system specified in **Annex B** for the mixed water temperature. This consists of, for example, a sensor (thermometer element or thermocouple) together with all associated equipment necessary to obtain a reading of Celsius temperature.

### C.2 Method

The method specified involves plunging the sensor from air at ambient temperature into flowing water at a higher temperature and measuring the time taken for the reading of Celsius temperature to rise by 90% of the difference between the air and water temperatures.

#### Note

The method specified is appropriate to the measurements of transient temperatures required by this specification and should provide repeatable results. However, the method should not be regarded as capable of measuring the absolute response time. To do this additional test equipment is needed.

### C.3 Apparatus

#### C.3.1 Water system

A water supply is required which can be adjusted both for temperature and flow rate and which is discharged through a pipe or nozzle into the atmosphere. The minimum dimension A of the water stream discharged into air shall not be less than  $5 \times D$ , where:

A = smallest cross-section dimension of the water stream in air between the end of the pipe or nozzle and 100 mm from the end of the pipe or nozzle when the flow velocity in the pipe or nozzle is  $1 \pm 0.1$  m/s;

D = the largest cross-section dimension of the immersed part of the thermometer element or sensor.

#### Note

In general the cross-section dimensions of the water stream are approximately equal to the cross-section dimensions of the pipe or nozzle.

#### C.3.2 Measuring equipment

The measuring equipment shall be the same as that used for the tests in **Chapter 7**. To enable the response time to be determined there shall be provision for synchronising the plunging of the sensor into water with the commencement of the time interval measurement.



### Note 1

Where a data logging system is used, the measured response time will frequently be overestimated, but never underestimated. Although a scan interval of 0.2 s is sufficiently fast to achieve the required accuracy of timing in [clause B.2.5](#), for the determination of thermometer response time this scan interval can overestimate the response time by more than 10 % in the range of permitted response times. A scan interval of 0.1 s should not overestimate by more than 0.01 s, and the possible error is reduced by more rapid scanning.

### Note 2

It may be sufficient to manually coordinate the plunging of the sensor into water and the commencement of timing. However, practice is necessary to achieve repeatable results.

## C.4 Procedure

- C.4.1 In the pipe or nozzle establish a flow of water having a velocity of  $1 \pm 0.1$  m/s. The dimensions of the water stream discharging into the atmosphere shall have the dimensions specified in [clause C.3.1](#).
- C.4.2 Measure the air temperature  $T_a$  close to the water stream. The air temperature shall be constant  $\pm 0.2$  K.

### Note

To achieve the required constancy of air temperature, a draught-protected environment may be needed.

- C.4.3 Adjust the temperature of the water stream in air  $T_w$  such that  $(T_w - T_a) = 20 \pm 2$  K. The water stream temperature shall be constant  $\pm 0.2$  K and the velocity in the pipe or nozzle shall remain at  $1 \pm 0.1$  m/s.
- C.4.4 With the test sensor in air close to the water stream, record the temperature that it indicates in association with its connected equipment (transmitter, amplifier, data logger, pen recorder etc). Then simultaneously plunge the sensor into the water stream and commence timing. The attitude of the sensor within the water stream shall be oblique to the flow with the tip of the sensor not more than 100 mm from the end of the pipe or nozzle and with the whole of the sensitive part of the sensor immersed. The temperature indicated by the test sensor and its associated equipment shall be monitored until the indication is constant  $\pm 0.2$  K.
- C.4.5 From a graph of the indicated temperature versus time, determine the response time  $\tau_{90}$  as the time taken to reach 90 % of the indicated difference  $(T_w - T_a)$ .
- C.4.6 Repeat the procedure in [clauses C.4.3 to C.4.5](#) to give at least five consecutive measurements of  $\tau_{90}$  that are constant to within 10 % of their average value.





**Note**  
With the exception of synchronisation (coordination) errors, the errors inherent in the procedure should tend to result in a larger value of response time than the absolute value. For this reason greater confidence may be placed in the smallest values measured, unless they are likely to be the result of synchronisation error.

## C.5 Results

The response time  $\tau_{90}$  shall be taken as the average of the three smallest values of at least five consecutive measurements of  $\tau_{90}$  that are constant to within 10% of their average value.



## Annex D (normative)

## Testing of further samples

D.1 In the event that no more than one of the three samples initially selected should fail to satisfy the requirements of the performance tests for a specific designation by margins no greater than those specified in **Table D.1**, a further two samples may be selected using the same random selection procedure. If the failed valve had been subjected to the durability of thermostat test specified in **clause 6.3**, then one of the two additional samples shall also be subjected to this test. If the two additional samples satisfy all of the requirements for that failed designation, then the product will be deemed to comply with this specification.

Requirement	Margin of failure
Clauses: 7.5.4.1; 7.6.4.1; 7.7.4.1; 7.8.4.1; 7.9.4.1	+10% on average duration of transient temperature rises.
Clauses: 7.5.4.2; 7.6.4.2; 7.7.4.2; 7.8.4.2; 7.9.4.2; 7.12.4.2	0.3 K on each steady mixed water temperature after restoration of initial supply conditions.
Clause 7.9.4.3	+10% on average leakage volume; 0.5 K on average reduction in mixed water temperature.
Clauses: 7.10.4.1; 7.11.3.1; 7.12.4.1;	0.5 K on average change in mixed water temperature.

Table D.1 Maximum margins of failure

AE

## Annex E (informative)

**Assessment of transient values**

E.1 An example of a transient temperature variation is shown in **Figure E.1**. The following information is taken from the graph:

- a. The duration at or above 45°C = 2.9 – 0.5 = 2.4 s
- b. The duration at or above 46°C = 2.5 – 0.53 = 1.97 s
- c. The duration at or above 47°C = 2.25 – 0.57 = 1.68 s
- d. The duration at or above 48°C = 1.99 – 0.6 = 1.39 s
- e. The duration at or above 49°C = 1.73 – 0.7 = 1.03 s
- f. The duration at or above 50°C = 1.52 – 0.7 = 0.82 s
- g. The duration at or above 51°C = 1.35 – 0.75 = 0.5 s
- h. The duration at or above 52°C = 1.13 – 0.8 = 0.33 s
- i. The duration at or above 53°C = <0.25 s

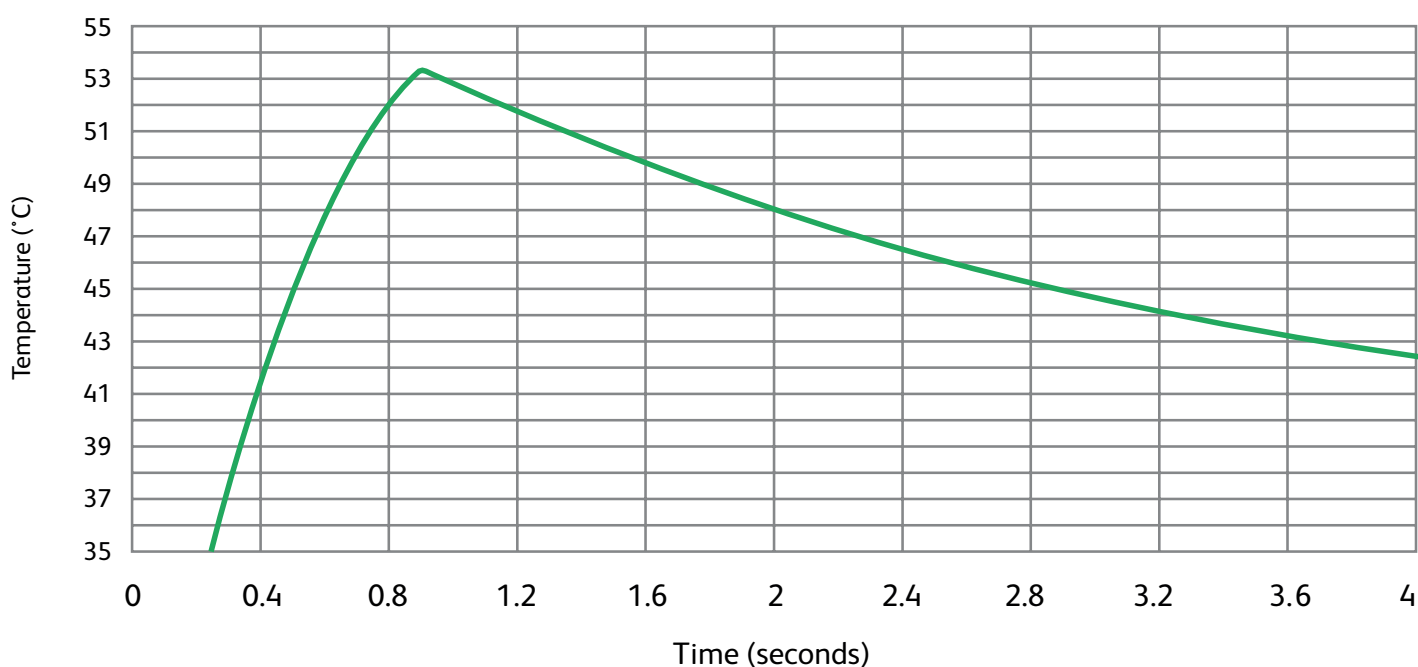

Figure E.1 Example of transient temperature variation



## Annex F (informative)

# Frequency of in-service tests

## F.1 General

In the absence of any other instruction or guidance on the means of determining the appropriate frequency of in-service testing, the following procedure may be used as a starting point.

The frequency of in-service testing and the specific requirements detailed in the risk assessment undertaken by the Water Safety Group may change due to a number of factors such as varying supply conditions and water quality as these may alter the TMV's performance.

- F.1.1 Six to eight weeks after commissioning, carry out the test given in [clause 11.2.2](#).
- F.1.2 Twelve to fifteen weeks after commissioning, carry out the test given in [clause 11.2.2](#).
- F.1.3 Depending on the results from [clauses F.1.1](#) and [F.1.2](#), several possibilities exist:
  - a. If no significant changes (for example  $\leq 1$  K) in mixed water temperatures are recorded between commissioning and the times given in [clause F.1.1](#), or between commissioning and the times given in [clause F.1.2](#), the next in-service test can be deferred to 24 to 28 weeks after commissioning.
  - b. If small changes (for example 1–2 K) in mixed water temperatures are recorded in only one of these periods, necessitating adjustment of the mixed water temperature, then the next in-service test can be deferred to 24 to 28 weeks after commissioning.
  - c. If small changes (for example 1–2 K) in mixed water temperatures are recorded in both of these periods, necessitating adjustment of the mixed water temperature, then the next in-service test should be carried out at 18 to 21 weeks after commissioning.
  - d. If significant changes (for example  $> 2$  K) in mixed water temperatures are recorded in either of these periods, necessitating service work, then the next in-service test should be carried out at 18 to 21 weeks after commissioning.
- F.1.4 The general principle to be observed after the first two or three in-service tests is that the intervals of future tests should be set to those which previous tests have shown can be achieved with no more than a small change in mixed water temperature.



## Annex G (normative)

# flow rate and sensitivity test of temperature control (alternative to angular or linear movement)

## G.1 General

G.1.1 This Annex details alternative tests for mixing valves that do not have a conventional temperature control lever for adjusting the mixed water temperature. All other test requirements for such products are the same as those specified in the main text of this specification.

G.1.2 The two categories of electronic temperature adjustment covered by this Annex are:

Category A valves: where the mixed water temperature controller produces a progressive temperature increase/ decrease for the time it is activated.

Category B valves: where the mixed water temperature controller produces a predetermined step temperature increase/ decrease for each time it is activated.

The indication of temperature adjustment will normally be visual but audible/vibratory indications are acceptable.

## G.2 Flow rate and sensitivity of temperature control (alternative to angular or linear movement)

### G.2.1 Purpose

The purpose of the test is to:

determine the flow rate of the mixed water;

determine the ease with which the mixed water temperature can be adjusted to the correct value for the intended application;

ensure that the electronic temperature control is not operated inadvertently;

enable the user to be aware of what the mixed water temperature is doing when making adjustments.

If a thermostatic mixing valve is suitable for more than one designation, this test can be conducted for all of these in a single test if the user adjustment range for mixed water temperature can be set to provide all of the required mixed water temperatures in one setting.

### G.2.2 Procedure

G.2.2.1 Connect the mixing valve to the test rig (see [Annex B](#)).

G.2.2.2 Fully open any integral flow control. Where outlet pipework is required, also open fully the valve 5 and the tap 6. Ensure that the bleed valves 8 are closed.



G.2.2.3 For mixing valves with user adjustment of the mixed water temperature, adjust the maximum mixed water temperature stop so that the full range of mixed water temperatures required in this test is available. For mixing valves with a preset temperature, access the mixed water temperature adjustment.

G.2.2.4 With the pressure losses and supply temperatures specified in **Table 8**, set the temperature control/adjustment to give a mixed water temperature equal to the first setting specified in **Table 7**.

Where outlet pipework is required, adjust the tap 6 to give the required pressure loss.

G.2.2.5 Record the mixed water flow rate and temperature and record the position of the temperature control/adjustment. Where outlet pipework is required, record the outlet pressure.

G.2.2.6 For category A valves as specified above, activate the temperature controller until the mixed water temperature reaches the values equivalent to settings 2, 3, 4 or 5 in **Table 7** as determined by the designation of the mixing valve.

At each setting, record the mixed water flow rate, the temperature and the time to reach each setting.

Alternatively the total time taken for the temperature to move from the first to the last setting can be measured and used to calculate the average time taken per position.

For category B valves as specified above, set the temperature control/adjustment to give a mixed water temperature equal to the first setting in **Table 7**. Activate the temperature controller one increment and measure the incremental change in the mixed water temperature. Continue to activate the temperature controller in single incremental steps measuring flow rate and mixed water temperature change at each setting, until the range determined by settings 1–5 in **Table 7** and the designation of the mixing valve have been covered.

Where outlet pipework is required, record the outlet pressure.

For category A and B valves, measure from the sensor the maximum distance required to activate the temperature adjustment as appropriate.

### G.2.3 Expression of results

Record the flow rates.

For category A valves, record the flow rate at each of the mixed water temperature settings determined by **Table 7**. Record the time taken to increase the mixed water temperature from the value equivalent to setting 1 to settings 2, 3, 4 or 5 in **Table 7**, as determined by the designation of the mixing valve. Alternatively the total time taken for the temperature to move from the first to the last setting can be measured so that an average time per setting can be calculated.



For category B valves, record the temperature change for each incremental adjustment required to increase the mixed water temperature from the value equivalent to setting 1 to settings 2, 3, 4 or 5 in [Table 7](#), as determined by the designation of the mixing valve.

#### G.2.4 Requirements

For category A valves, the temperature/time increase characteristic specified in [Table 7](#) shall be a maximum of 1 K per second throughout the temperature range.

For category B valves, each step change in temperature shall be 1 K maximum.

The flow rate shall at no point be less than the value specified in [Table 8](#) for the designation of valve, except that for those valves designated with suffix E the flow rate shall be less than 8 L/min.

The maximum distance for activation of the electronic temperature controller shall be 50 mm.

A visual/audible/vibratory indication built into the product is required to inform the user whether the temperature is rising or falling when they are adjusting the mixed water temperature as well as indicating its maximum and minimum temperature positions.

## G.3 Mixed water temperature overshoot on adjustment of mixed water temperature

### G.3.1 Purpose

The purpose of the test is to determine, for thermostatic mixing valves having a user-adjustable mixed water temperature setting, the characteristic of any transient rise in the mixed water temperature that may occur when the mixed water temperature setting is suddenly changed from a cool setting to the maximum setting.

### G.3.2 Procedure

G.3.2.1 Connect the mixing valve to the test rig (see [Annex B](#)).

G.3.2.2 Starting from the initial setting (see [Table 9](#)), allow mixed water to flow for 2 min ± 5 s and then measure and record the mixed water temperature.

G.3.2.3 Adjust the position of the temperature control to give a mixed water temperature of 30 ± 1 K (or, if the lowest temperature available is greater than this, to the lowest temperature available).



G.3.2.4 After 3 min ± 15 s rapidly adjust, by hand and as fast as possible, the temperature of the mixed water. For category A valves this shall be done by activating the temperature controller until the mixed water temperature reaches its maximum position. For category B valves this is done by activating the temperature controller as quickly and as many times as is necessary for the mixed water temperature to reach its maximum position.

G.3.2.5 Monitor and record the mixed water temperature.

G.3.2.6 Repeat the procedure to give three sets of results for each sample.

### G.3.3 Expression of results

The temperature transient obtained shall be assessed to determine the duration at or above each 1 K temperature rise shown in **Table 10** for the appropriate designation. For the three test results on each sample calculate the average duration at each temperature rise. Transient temperature rises shall be referred to the mixed water temperature existing at the start of each of the three tests.

#### Note

An example of the assessment of test results is given in **Annex E**.

### G.3.4 Requirements

The average duration of the transient temperature rise at or above each 1 K temperature rise shown in **Table 10** for the appropriate designation shall not be longer than the values given in **Table 10**. Individual test results shall not exceed the permitted duration by more than 10%.

For each result the final mixed water temperature shall not differ from the actual initial setting of the sample concerned by more than 2 K.





## References

The latest version of any standard should be used, provided that it continues to address the relevant requirements of these recommendations <http://shop.bsigroup.com/en/>

### British and European Standards

BS 6920:2014 [parts 1 and 2]. *Suitability of non-metallic materials and products for use in contact with water intended for human consumption with regard to their effect on the quality of the water.*

BS 6920 [Parts 1-3 +A1] *Suitability of non-metallic products for use in contact with water intended for human consumption with regard to their effect on the quality of the water.*

\*BS EN 1111:1999. *Sanitary tapware. Thermostatic mixing valves (PN 10). General technical specification.*

\*BS EN 1287:1999. *Sanitary tapware. Low pressure thermostatic mixing valves. General technical specifications.*

\*marked work in hand at time of publication

### NHS Wales Shared Services Partnership - Specialist Estates Services

Health Technical Memoranda (HTMs) and Health Building Notes (HBNs) issued by the Department of Health in England are being superseded by specific Welsh editions which will be titled Welsh Health Technical Memoranda (WHTMs) and Welsh Health Building Notes (WHBNs) and which will use the same numerical coding. The guidelines referenced below were the most recent at time of publication; however, *the latest version should always be used, provided that it continues to address the relevant requirements of these recommendations.* All are available from the NHS Wales Shared Services Partnership – Specialist Estates Services websites:

Intranet: <http://howis.wales.nhs.uk/sites3/page.cfm?orgid=254&pid=39106>

Internet: <http://www.wales.nhs.uk/sites3/page.cfm?orgid=254&pid=6142>

#### Welsh Health Technical Memorandum (HTMs)

WHTM 04-01 Part A:2016 *Safe water in healthcare premises Part A: Design, installation and commissioning*

WHTM 04-01 Part B:2016 *Safe water in healthcare premises Part B: Operational management*

WHTM 04-01 Part C:2016 *Safe water in healthcare premises Part C: Pseudomonas aeruginosa – advice for augmented care*



## Other publications

Water Regulations Advisory Scheme (2013). *A guide for manufacturers, suppliers and test laboratories on the application requirements for WRAS material approval*  
[https://www.wras.co.uk/downloads/public\\_area/documents/8.4.2.3\\_-\\_wras\\_materials\\_guidance\\_3.44.pdf/](https://www.wras.co.uk/downloads/public_area/documents/8.4.2.3_-_wras_materials_guidance_3.44.pdf/)

Health and Safety Executive (2012). *Managing the risks from hot water and surfaces in health and social care [HSIS6]*.  
<http://www.hse.gov.uk/pubns/hsis6.htm>