

### Decontamination of flexible endoscopes

#### *Part B: Design and installation*

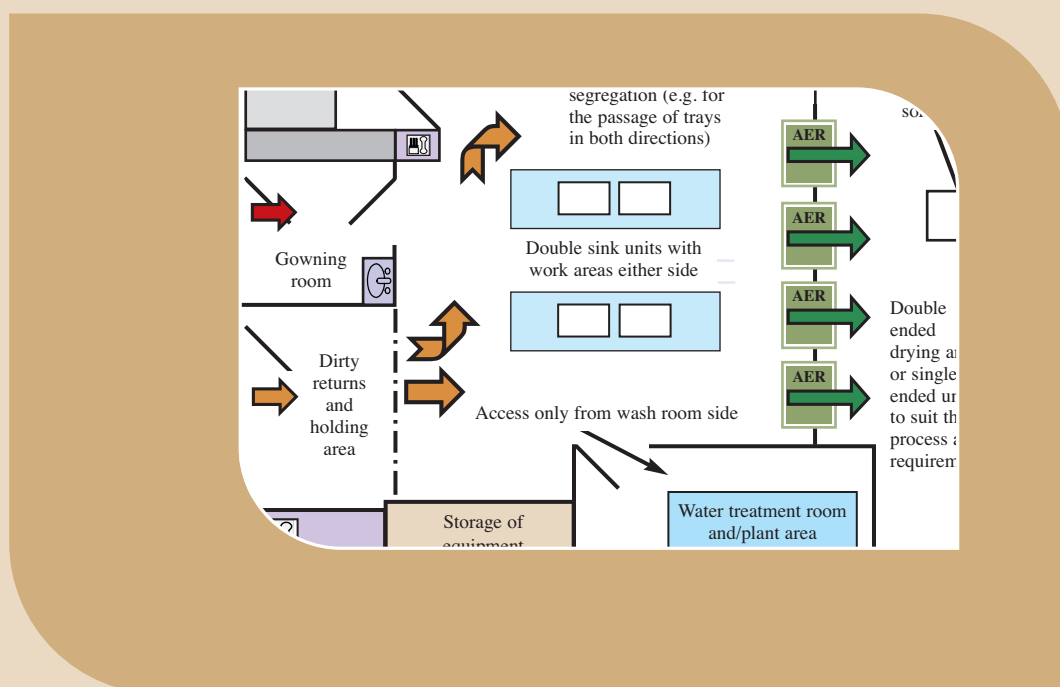

GIG  
CYMRU  
NHS  
WALES

Partneriaeth  
Cydwasaethau  
Gwasanaethau Cyfleusterau  
Shared Services  
Partnership  
Facilities Services

## Disclaimer

The contents of this document are provided by way of general guidance only at the time of its publication. Any party making any use thereof or placing any reliance thereon shall do so only upon exercise of that party's own judgement as to the adequacy of the contents in the particular circumstances of its use and application. No warranty is given as to the accuracy, relevance or completeness of the contents of this document and NHS Wales Shared Services Partnership – Facilities Services shall have no responsibility for any errors in or omissions therefrom, or any use made of, or reliance placed upon, any of the contents of this document.

**Note:** Heath Building Notes (HBNs) and Health Technical Memoranda (HTMs) issued by the Department of Health in England are being superseded by specific Welsh editions which will be titled Welsh Heath Building Notes (WHBNs) and Welsh Health Technical Memoranda (WHTMs). Until this process is complete, where a WHBN or WHMT is referred to in the text but has not yet been published, refer to the relevant publications page on the NHS Wales Shared Services Partnership – Facilities Services website for the latest approved document.

Intranet: [howis.wales.nhs.uk/whe](http://howis.wales.nhs.uk/whe)

Internet: [www.wales.nhs.uk/whe](http://www.wales.nhs.uk/whe)

Published by NHS Wales Shared Services Partnership – Facilities Services

This guidance is based on the *Choice Framework for local Policy and Procedures (CFPP) 01-06 Decontamination of flexible endoscopes: design and installation* guidance published by the Department of Health

This publication can be accessed from the NHS Wales Shared Services Partnership – Facilities Services website [www.wales.nhs.uk/whe](http://www.wales.nhs.uk/whe)

ISBN: 978-1-909899-18-6

© Copyright NHS Wales Shared Services Partnership – Facilities Services 2014

This is a new guidance document except for the elements dealing with AER testing which supersede archived Health Technical Memorandum 2030

Cover image by courtesy of NWSSP-FS

Cover designed by Keith James

# Overview

## Scope of Welsh Health Technical Memorandum 01-06 Parts A, B, C, D and E

Welsh Health Technical Memorandum (WHTM) 01-06 is part of a suite of evidence-based policy and guidance documents on the management and decontamination of reusable medical devices designed to reflect the need to continuously improve outcomes in terms of:

- patient safety;
- clinical effectiveness;
- patient experience.

It is also designed to reflect the need to ensure the environment in which decontamination procedure are carried out is fit for purpose.

The WHTM 01-06 suite of documents supersedes the relevant parts of Health Technical Memorandum 2030 dealing with endoscope decontamination.

The documents allow local decisions to be made in the formulation of an appropriately developed, risk controlled, operational environment within the healthcare facilities that decontaminate flexible endoscopes. They also set out how the decontamination of reusable medical devices can be carried out in a cost effective way using risk assessment controls and procedures whilst placing patient safety as its top priority.

Guidance is also offered on the management and decontamination of flexible endoscopes, principally gastrointestinal scopes and bronchoscopes. They also aim to support healthcare establishments in implementing appropriate and effective decontamination measures to reduce the risks of person-to-person transmission of human prion diseases.

WHTM 01-06 is divided into five parts:

**Part A: Policy and management** sets out the Welsh Government's policy for an endoscope decontamination service. The document covers flexible endoscope management and decontamination only. Clinical issues relating to endoscopy or the manufacture of Automated Endoscope Reprocessors (AERs) are not discussed. Furthermore, this document does not cover the processing of flexible endoscopes used to examine sterile body sites. These endoscopes should be sterile, possibly using low temperature gas sterilization, and may be the subject of future guidance.

The document discusses transmissible spongiform encephalopathy (TSE) infectious agents and sets out guidance on the management and handling of endoscopes after they have been used on patients at increased risk of vCJD.

**Part B: Design and installation** sets out guidance on the design and installation of endoscope reprocessing units.

**Part C: Operational management** sets out guidance on operational responsibilities together with advice on the procurement and operation of automated endoscope reprocessors (AER).

**Part D: Testing methods** discusses the principles and methods that are used in the tests described in this WHTM and detailed in BS EN ISO 15883-4.

**Part E: Validation and verification** highlights the types of tests and maintenance procedures that are needed to provide evidence that decontamination has been achieved.

### Note

This WHTM 01-06 is based on continued improvement of standards of delivery at the point of use and the continuing aim of reducing the risk element to both users and patients. The technology involved is constantly improving to meet the demands of the service and evidence based results and research should always be investigated.

## Who should use WHTM 01-06 Part B

Part B is intended as a guide for management, for technical personnel with appropriate training and experience and also for users responsible for the day-to-day running of decontamination equipment. It will also be of interest to microbiologists, infection control officers, architects, planners, estates managers, supplies officers, and others in both the public and private sectors.

# Acknowledgements

Listed below are the contributors to the CFPP guidance published by the Department of Health (England) which provided the basis for this WHTM.

**Brian Kirk** IHEEM Decontamination Technology Platform

**Clive Powell** Association of British Healthcare Industries

**Gavin Maxwell** Royal Society of Medicine Patients Support Group

**Geoff Sjogren** Institute of Decontamination Sciences

**Geoffrey L. Ridgway**, OBE, MD Clinical Microbiologist

**Gerry McDonnell** Association of British Healthcare Industries

**Graham Stanton** NHS Wales Shared Services Partnership – Facilities Services and IHEEM Decontamination Technology Platform

**Helen Griffiths** Joint Advisory Group on gastrointestinal endoscopy (JAG)

**Jackie Duggan** Health Protection Agency

**James Ironside** University of Edinburgh

**Jimmy Walker** Health Protection Agency

**Karen Chell** NHS Supply Chain

**Ken Toal** Health Estates, Northern Ireland

**Mike Painter** Public Health Physician

**Mike Simmons** Public Health Wales

**Miles Allison** British Society of Gastroenterology

**Peter Hoffman** Health Protection Agency

**Robert Kingston** IHEEM Decontamination Technology Platform

**Stuart Line** (main author) Sterilizer Consultants

**Sulisti Holmes** Health Protection Scotland

**Tony Young** Southend University Hospital NHS Foundation Trust

**Tracy Coates** Association for Perioperative Practice

Listed below are the contributors to this Welsh Health Technical Memorandum who sit on the WHTM Guidance Peer Group as directed by the Welsh Government's All Wales Decontamination Group.

**Jenny Thorne** Welsh Government

**Mike Simmons** Public Health Wales

**Eleri Davies** Public Health Wales

**Alison Griffiths** Hywel Dda Health Board

**Eric Thomas** NHS Wales Shared Services Partnership – Facilities Services

**Graham Stanton** NHS Wales Shared Services Partnership – Facilities Services

**John Prendergast** NHS Wales Shared Services Partnership – Facilities Services

**Simon Russell** Wales Shared Services Partnership – Facilities Services

**Peter Wiles** NHS Wales Shared Services Partnership – Facilities Services

# Abbreviations

**AE(D):** Authorising Engineer (Decontamination)

**AE(MG):** Authorising Engineer (Medical Gases)

**AER:** Automated endoscope reprocessor

**BS:** British Standard

**CMO:** Chief Medical Officer

**COSHH:** Control of Substances Hazardous to Health

**CP(D):** Competent Person (Decontamination)

**EN:** European norm

**IP:** Ingress protection

**ISO:** International Standards Organisation

**NWSSP-FS** NHS Wales Shared Services Partnership –  
Facilities Services

**PPE:** Personal protective equipment

**RO:** Reverse osmosis water

**TOC:** Total organic carbon

**TVC:** Total viable count

**WHBN:** Welsh Health Building Note

**WHTM:** Welsh Health Technical Memorandum

# Contents

<b>Overview</b>	3
<b>Acknowledgements</b>	4
<b>Abbreviations</b>	5
<b>Chapter 1 Design of an endoscope reprocessing unit or facility</b>	8
Introduction	
Layout of the unit	
Single-room decontamination area	
Siting of AERs	
Wash room	
Decontaminated equipment room	
Transport and storage of decontaminated endoscopes	
Example layouts that provide the design principles for endoscope decontamination rooms	
Design of an endoscope reprocessing unit for a local unit or small hospital	
Access to engineering services	
<b>Chapter 2 Water quality and water treatment</b>	21
Water quality	
Initial and intermediate rinse stages	
Final rinse-water	
Chemical process residues	
Water used to dilute chemicals	
Key factors affecting the quality of water	
Water hardness	
Temperature	
Ionic contaminants	
Microbial contamination	
Deposits from water	
Bacterial endotoxins	
Total organic carbon (TOC)	
Legionella and Pseudomonas aeruginosa	
Water treatment options	
Water softeners	
Water deionisers	
Distillation	
Reverse osmosis (RO)	
Filtration	
Disinfectant addition	
Water treatment plant	
Tests for purity levels	

- Chemical purity
- Organic purity
- Microbial purity
- Pipework
- Biofilm formation
- Water supply regulations and services

**Chapter 3 Engineering services** 30

- Summary for all Health Boards / Trusts and healthcare establishments
- Ancillary equipment
- Water services
- Electrical services
- Drainage
- Hazardous effluents
- Ventilation
  - General room ventilation
  - AER ventilation
- Chemical additives
- Infectious materials
- Engineering services checklist

**References** 36

# Chapter 1 Design of an endoscope reprocessing unit or facility

## Introduction

- 1.1 Suitable decontamination facilities should exist on all sites where flexible endoscopy procedures are carried out. A team consisting of users and designers should review the location and standard of existing facilities. The review should include an assessment of the layout and of the operational procedures. If required, the facilities should be upgraded in accordance with the guidance set out in this document. Should real constraints prevent such upgrading, such as lack of space, incorrect flow paths, poor accessibility, the local infection control policy and frequency of use, serious consideration should be given to relocating the facility to a more suitable site. Given the competing demands in an endoscopy department and the Welsh Government's wish to see decontamination being treated as a discipline in its own right, placing decontamination of endoscopes under the care of a separate decontamination facility has much to commend it.
- 1.2 The approach to the design of an endoscope reprocessing unit will depend on its likely size and the number of procedures to be performed each week. The requirements for a large unit contained in a general hospital will be significantly different from those in a small endoscopy unit forming part of a community hospital or independent hospital. However, regardless of size or clinical role, the primary aim is to ensure an environment in which successful risk control is achieved in the management and decontamination of endoscopes (see [Figure 1](#)).
- 1.3 The development of a small or large endoscopy unit is likely to follow the same pattern in the initial stages in the review and assessment procedures. The schedule shown in [Table 1](#) provides a list of possible development considerations. The Health Board / Trust or healthcare establishment assessment team as detailed in WHTM 01-06 Part A – 'Policy and management', NHS Wales Shared Services Partnership – Facilities Services (NWSSP-FS) and the Authorising Engineer (Decontamination) (AE(D)) will be able to provide advice on the design of an endoscope reprocessing unit.
- 1.4 In accordance with prevention and control of infections and related guidance, standards of cleanliness are important to the maintenance of high attainment in the endoscope management and reprocessing service. All areas used as part of this process should be subject to basic visual scrutiny at reasonable intervals. It is important to ensure that the equipment necessary to support cleanliness is available and accessible from all of the areas where endoscope reprocessing takes place. The availability of separate sinks and wash-hand basins for use by staff is an important consideration. The decontamination lead and infection control team should be consulted on the attainment and maintenance of general hygiene standards.
- 1.5 Ideally, endoscopes should not be transported between hospitals for decontamination. Where routine operation or contingency planning requires the transport of endoscopes between hospitals or centres, a risk assessment should be undertaken to consider all the factors that may affect the transport of clean reprocessed endoscopes and those that will affect the handling of dirty returned endoscopes. The conditions of the Carriage of Dangerous Goods and Use of Transportable Pressure Equipment Regulations 2009 will need to be considered when dirty endoscopes are transported by a third-party carrier. Procedures and equipment used in transport should provide for effective prevention of infection with particular attention to the separation of clean and dirty equipment.
- 1.6 Provision may be made within an operating department, under exceptional circumstances, for an endoscope decontamination facility to reprocess endoscopes that cannot be returned to the designated facility or central decontamination area. This should be recognised as a risk by the Health Board / Trust. The facility should be provided in a room dedicated for this purpose with appropriate



manual cleaning facilities and an AER. The standard of decontamination should be the same as that carried out in a dedicated endoscopy unit. In addition, staff training should be similar to the training obtainable in the main endoscopy unit. The management of such a unit should be based upon the standards and principles of a central

endoscopy decontamination department. Where a health facility establishes such systems, management should ensure the decontamination lead has processes in place to manage and reassure the Health Board/Trust over compliance with these standards.

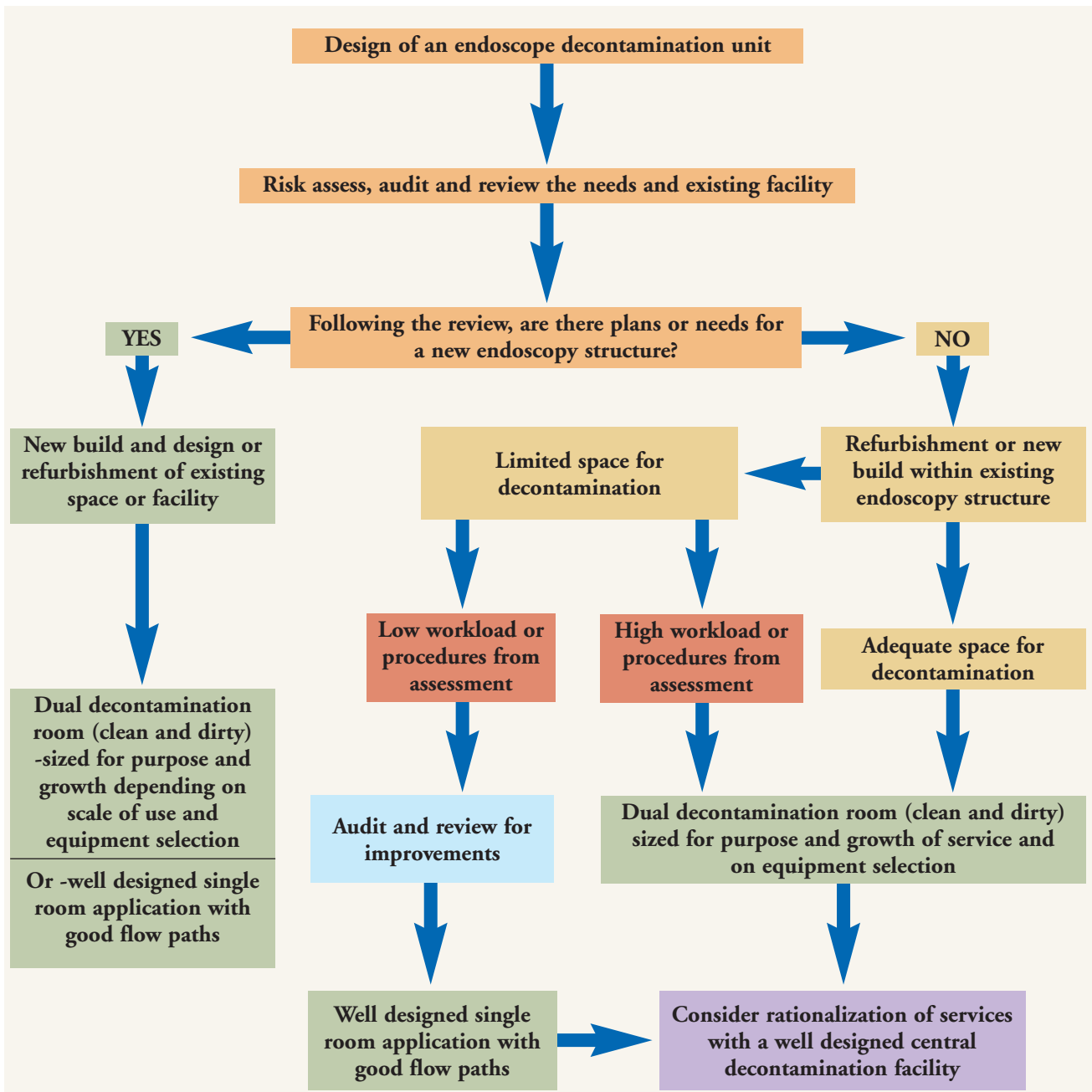

Figure 1: Design examples for an endoscope reprocessing unit or facility

1	Endoscope reprocessing units should be working towards the medical devices quality management system BS EN ISO 13485 and operate in a manner consistent with the Medical Devices Regulations. The schematic in <b>Figure 1</b> will assist in this process.
2	The use of double-ended endoscope washer-disinfectors (AERs) with separate clean and dirty rooms (two-room option) should be considered in a larger or very heavy workload unit. Where, as a result of the assessment, this design and layout is not required, single-ended AERs should be used with clear dirty to clean flow path of the endoscopes.
3	The assessment of endoscope decontamination facilities should include:
a	Consideration of staffing levels needed to work in the decontamination unit, with the objective of minimising staff movements.
b	The available space given for the whole process, e.g. the wash room size, sink numbers and staff levels required to work within.
c	User requirements with regard to the number of sessions or clinics being undertaken in a week and throughput level of endoscopes.
d	AER selection - Design of AER, e.g. pass through type, single sided/top loader or cassette design.
e	The workload that will determine the number of AERs required for reprocessing the endoscopes used within the unit's opening time. The cycle process time should be considered when new AER designs are purchased in order to calculate how many endoscopes can be processed in a day. An allowance should be made for 60% usage time and 40% down time for testing and service requirements.
f	The needs for manual cleaning, for example, number of sinks, bench area. Welsh Health Building Note 13 – 'Sterile services department' contains useful advice;
g	How reprocessed endoscopes are to be stored in drying cabinets or standard storage units. The cabinet design will influence the numbers, size, space and where they are to be sited; if the drying cabinet is to be stored in a clinical environment away from the decontamination area, consideration should be given to the methods of safe transit of decontaminated scopes to that area.
	<b>Note</b> The use of validated systems to store endoscopes in a safe manner for an elongated period, e.g. drying cabinets will reduce significantly the reprocessing times, the additional expense of process water/chemicals and the number of times an endoscope is put through the system.
h	The need to plan for the removal of endoscopes from clean storage. This will require significant space and good access for staff.
i	The need to determine the IT requirements, including the traceability system, the number of workstations, printers, etc. required for the process.
j	The need to calculate the ventilation requirements for particular reprocessing systems and process chemicals used together with staffing levels. If the endoscope decontamination facility is divided into clean and dirty areas or rooms, the ventilation system should be designed accordingly for the dirty wash area and clean processing or storage to the recommendations given in Appendix 2 of WHTM 03-01, Part A 'Specialised ventilation for healthcare premises'. An appropriate risk assessment for the treatment room, for example, tuberculosis risk, should be carried out, taking account of the air-change rates for treatment rooms and wash rooms. In addition, the space required for ductwork and the correct positioning of supply and extract air diffusers should be determined. The wash room should be negative or equal to surrounding areas for the pressure regime (in accordance with WHBN 13).
4	The endoscopy layout should take into account: <ul style="list-style-type: none"> <li>• access to patient areas</li> <li>• the need for changing-room facilities</li> <li>• staff rest rooms and changing rooms</li> <li>• the need for a water treatment plant</li> <li>• space for a cleaners' cupboard, particularly for the wash room.</li> </ul>

**Table 1: Considerations of development for an endoscopy unit**

## Layout of the unit

- 1.7 It is important to ensure that the workflow within the department is from dirty to clean areas to avoid the possibility of recontamination of reprocessed endoscopes from surfaces contaminated by unprocessed devices. This can be achieved in many ways depending on space available, equipment and location.

### Single-room decontamination area

- 1.8 The decontamination room should have two entrance options as illustrated in [Figure 2](#). Ideally, two entrances should be utilized for staff to form clear pathways, but the endoscope path could be in the form of hatches (clean and dirty), or double ended drying cabinet as illustrated. If an existing space is to be used to form the decontamination room, a single door application can be risk assessed and covered by clear designated procedures to document the practices being used within the room. If a single room decontamination area is implemented, the adherence to the designated procedures is essential to minimise the possibility of cross infection, recontamination of decontaminated devices or accidental release of unprocessed equipment.

### Endoscope pathway

- one hatch or door used for dirty endoscopes returning from the treatment area; and
  - one hatch or door/cabinet for the delivery of reprocessed clean endoscopes for the next procedure.
- 1.9 Facilities should be provided for convenient access to the traceability system so the endoscope data can be entered onto the database.
- 1.10 [Figure 2](#) in 'Example layouts' illustrates a single room decontamination unit that can be designed for many applications either as a standalone unit or within a theatre complex.
- 1.11 A flow of work can be based on the process described in WHTM 01-06 Part C – 'Operational management'.
- 1.12 The layout of equipment in the decontamination room should be based on carrying out the above procedure without crossover or recontamination of reprocessed endoscopes.
- 1.13 In addition to endoscope decontamination, the decontamination of storage/transport systems and trays or the use of disposable liners is recommended. In addition, transport trolleys should be considered for decontamination as

necessary. This should be considered as part of operational risk assessment.

### Testing time requirements

- 1.14 In addition to the operating time of an AER, the testing and service time should be factored into the calculation. Weekly testing will take up production time. The testing time will depend on the design and location of the AER and will take at least one hour. The periodic tests performed to Table 5 in WHTM 01-06 Part D – 'Validation and verification' will involve the loss of use of the AER for up to one day each quarter. Depending on the testing, the loss of use for annual validation can be several days. Again this will be dependent on the design and specification of the AER.
- 1.15 Spare AER capacity will be required to allow for maintenance and breakdown. It is recommended that machines should be used alternatively and not be allowed to lie idle. AERs do not provide a reliable service if left idle for days or weeks, as biofilm will grow in internal tubes and valves. In addition, tubes containing chemicals may drain; so the first cycle of use after a rest period may not take up the correct volume of fluids. It is good practice and in line with many manufacturers' recommendations to run AERs at least daily in order to reduce the potential for bio-film formation within the internal circulation system of the AER. Furthermore, the AER should also operate on a self-disinfection cycle daily.

### Siting of AERs

- 1.16 The position of the AER is a key decision to be made when designing a decontamination room, as it may determine the size of the room, the position of other facilities and engineering considerations. More information on this topic can be found in WHTM 01-06 Part C for AER selection.

#### Note

If an endoscope reprocessing unit is to be built or refurbished, a risk assessment should be carried out, carefully considering spatial requirements, the layout and design of the unit, the design of the AERs, the room operation, the number of staff that will carry out the decontamination procedures and hours of use. The numbers of endoscopes and the patient numbers in a clinic session determine the frequency of decontamination required. The chart in [Figure 1](#) should guide the design, from single room to twin room operation. If a larger design is needed because of high use, the twin room design is the preferred option.

- 1.17 The room in which an AER is installed and operated should meet the requirements of the Workplace (Health, Safety and Welfare) Regulations. These regulations have considerable implications for the accommodation of AERs.
- 1.18 Fire safety precautions should comply with Approved Document B – ‘Fire safety’, which accompanies the latest Building Regulations (as amended), and the WHTM Firecode suite of documents. Advice from NWSSP-FS should be sought.

### Wash room

- 1.19 The wash room area provides space to:
- off-load soiled returns from trolleys in a safe manner; a soiled returns hold area should be conveniently located, where collection trolleys containing soiled returns can be held.
  - clean transport trolleys, if used. These trolleys and associated trays should be made of a cleanable material and tray liners should be used so that endoscopes do not come in direct contact with the trolleys and trays.
  - sort items for disposal or appropriate cleaning and disinfection;
  - clean and disinfect items able to be reprocessed;
- 1.20 The storage of PPE and hand-washing facilities and adequate space for staff to implement the policies should be provided.
- 1.21 Manual cleaning facilities will also be required. The provision of these facilities must include consideration of the following:
- The requirement for a stainless steel double sink designed for washing/rinsing of dirty flexible endoscopes. The choice of sink should take into consideration the following points:
    - (i) It should be deep enough to allow complete immersion of endoscopes;
    - (ii) The size and base area should be adequate;
    - (iii) It should include a double drainer;
    - (iv) Care should be taken to ensure that an ergonomic assessment is undertaken and that the health and safety of staff operatives of variable height is considered. Where variable height sinks are used, the possibility of trapping hazards should be recognised and appropriately controlled.
  - Measurement and monitoring of the manual wash process with detergent solution is recommended in order to ensure optimum dilution rates and to ensure the temperature of the water is within the range documented in

chemical supplier’s specification for optimum performance of detergents used during process.

- **Wherever possible, sinks used for manual cleaning should be supplied with water directly from the main supply.** Reference should be made to CMO (2010)04, Decontamination of medical devices – automated endoscopy reprocessors and potable water,

### Note

Tank water can often be contaminated and the cleaned endoscopes will be subjected to bioburden from retained water. Branches that have minimal water flow and dead legs in the supply system will also allow biofilm to form in the pipes. The use of a jet washer is discouraged. Problems have been found with the use of sinks fitted with a rinse recirculating system for flushing lumens. Bacterial growth can occur in such a system causing cleaning problems. If such a design is to be utilized, clear guidance on cleaning and test procedures should be given by the manufacturer or supplier. The system should be disinfected before use and drained dry when not in use. The disinfection procedure given by the sink manufacturer will need to be followed and any test results evaluated. If this procedure is not followed, the biofilm that can exist in these systems can cause problems to endoscopes washed subsequently in these devices.

- A range of brushes must be available to suit the type, design and correct channel(s) of endoscopes being cleaned.
- Guidance procedures must be provided for the Operator giving details relating to the different types of endoscope being reprocessed and suitable brushing techniques.

### Decontaminated equipment room

- 1.22 The decontaminated equipment room is sited on the clean side of the AER and should have a separate staff access to the dirty area. In larger units with separate clean and dirty rooms, endoscopes should not pass into the decontaminated equipment room unless they have passed through the AER.
- 1.23 The decontaminated equipment room may house drying cabinets and, if required, clean transport trolleys for the distribution of reprocessed endoscopes in systems that are designed to maintain the integrity of the device until point of use.

### Note

If there is no separate decontaminated equipment room, the transfer of cleaned and disinfected items to the endoscope storage facility should take place without crossing the path of soiled instruments.

**Transport and storage of decontaminated endoscopes**

1.24 In a small or very busy endoscopy unit, it is likely that reprocessed endoscopes will be used directly after they have been cleaned in an adjacent room, or they will be stored for the next clinic. Where the transfer of endoscopes to another department occurs, consideration should be given to the transport system and the method of carrying endoscopes during transit. There are numerous transport systems being developed by manufacturers due to the significant changes in the service and the growing need of endoscopy procedures. Any new system should provide the required validation data to verify the performance of its design and the ability to maintain medical devices in a safe condition until use.

**Example layouts that provide the design principles for endoscope decontamination rooms**

1.25 The example layouts in this section show the concepts that are important in endoscope decontamination room design. They are not intended to be specific room layouts, and variations incorporating the design philosophy are acceptable.

1.26 Room layouts are intended to support good decontamination practice by trained operators.

1.27 If operational practices require endoscopes to be stored for extended periods after decontamination, endoscope drying cabinets should be considered. If endoscopes are to be used soon after decontamination, non-drying storage cabinets can be utilized. Selection and security of process along with the design has to be considered.

1.28 Many of the procedures carried out within these facilities are demanding in terms of clear sight of small components, fittings, accessories and visible contamination. This will require careful attention to the design of a lighting strategy consisting of lighting utilising diffusers where appropriate and supported by task lighting for the detailed observation of endoscopes and associated equipment (see latest CIBSE ‘Lighting Guide 02: Hospitals and Health Care buildings’).

1.29 Surfaces in contact with endoscopes and their components or those likely to be contaminated should be impervious, easily cleaned and be able to withstand disinfection (see WHBN 00-09 – ‘Infection control in the built environment’ and WHBN 00-10 Part A – ‘Flooring’, WHBN 00-10 Part B – ‘Walls and ceilings’ and WHBN 00-10 Part C – ‘Sanitary assemblies’).

1.30 As shown in **Figure 2**, there must be a clearly designated flow from dirty to decontaminated so that there is never uncertainty about which stage of decontamination an endoscope has reached as it

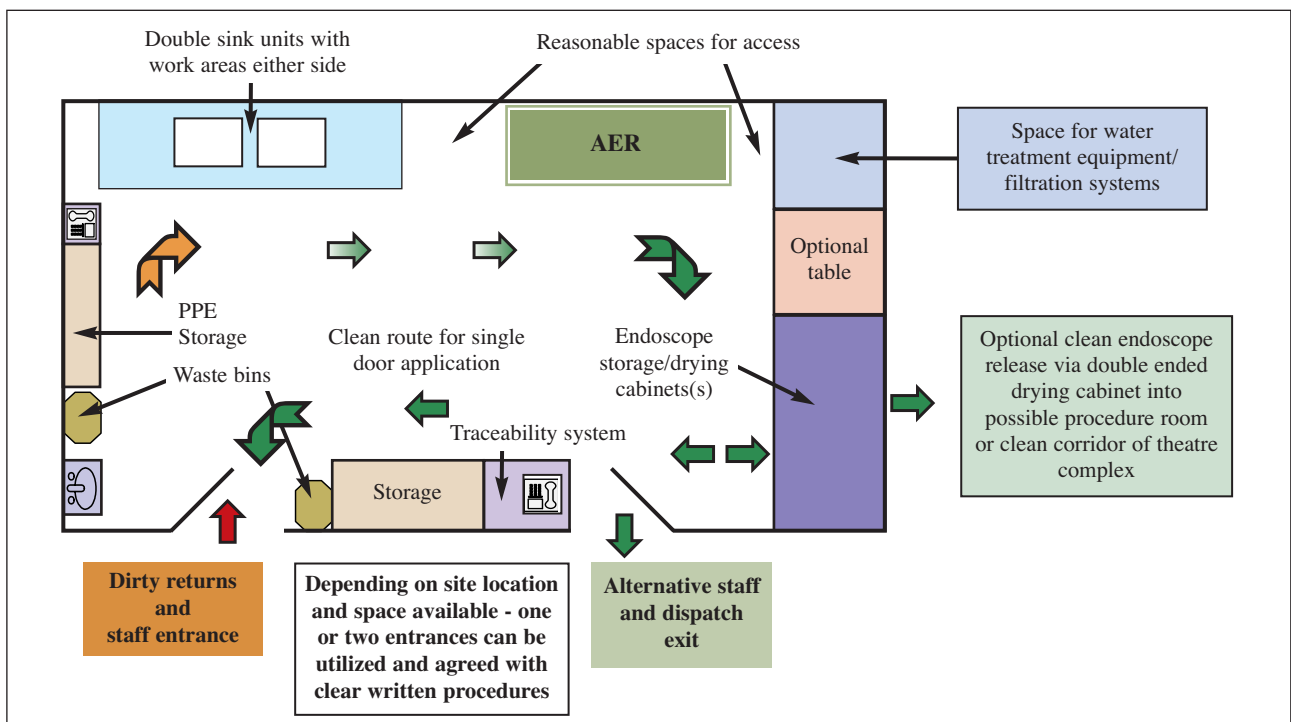
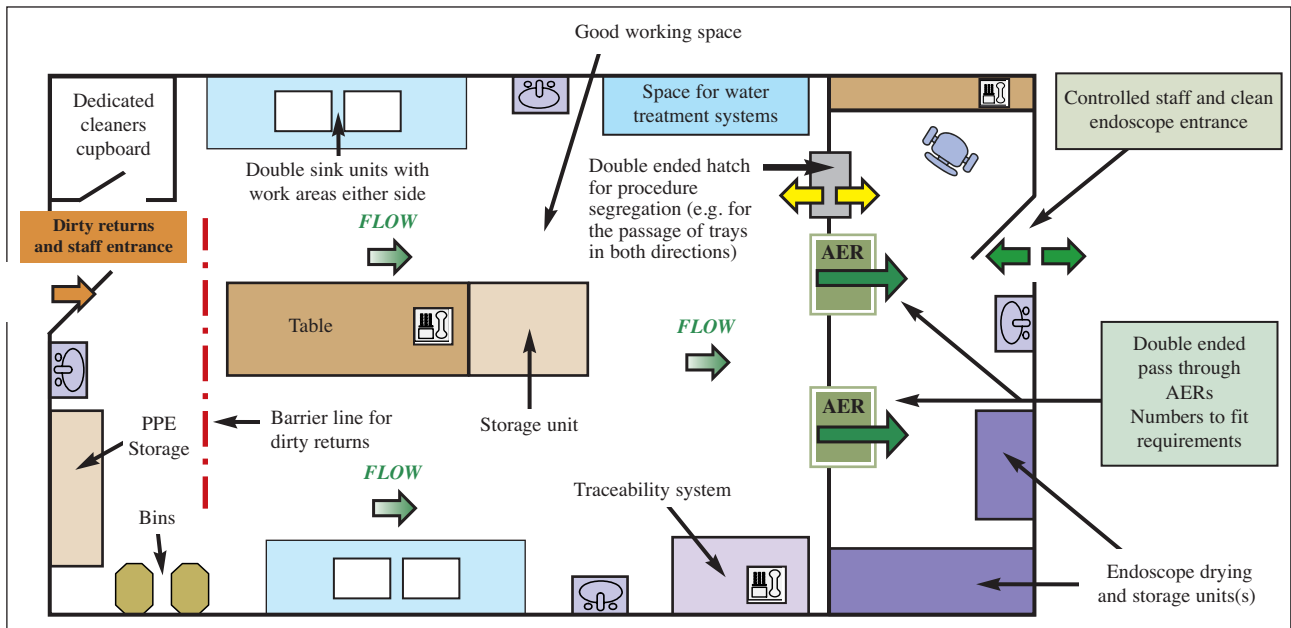

**Figure 2: Single room design**

progresses from dirty to clean. A risk assessment should be used to support the design process and further determine whether there is a probable future need for separate clean and dirty rooms if the requirements or reprocessing equipment design change (e.g. pass through AERs) or departmental throughput significantly increases. Regardless of the design option chosen, it is essential that the room floor area be adequate to support the full process of endoscope management and decontamination without compromising quality. While it is acceptable for units to depend on a single AER in

terms of decontamination quality, the operational implications of breakdown and maintenance should be carefully considered.

- 1.31 **Figure 3a** uses double-ended AERs and may be preferred if a risk assessment indicates this requirement depending on frequency of work, workload per list and staffing levels to operate the design and equipment.
- 1.32 **Figure 3b** makes use of a standalone type or single-ended AERs but with a clearly designated flow from dirty to decontaminated endoscopes such that



**Figure 3a: Double room decontamination unit – option 1**

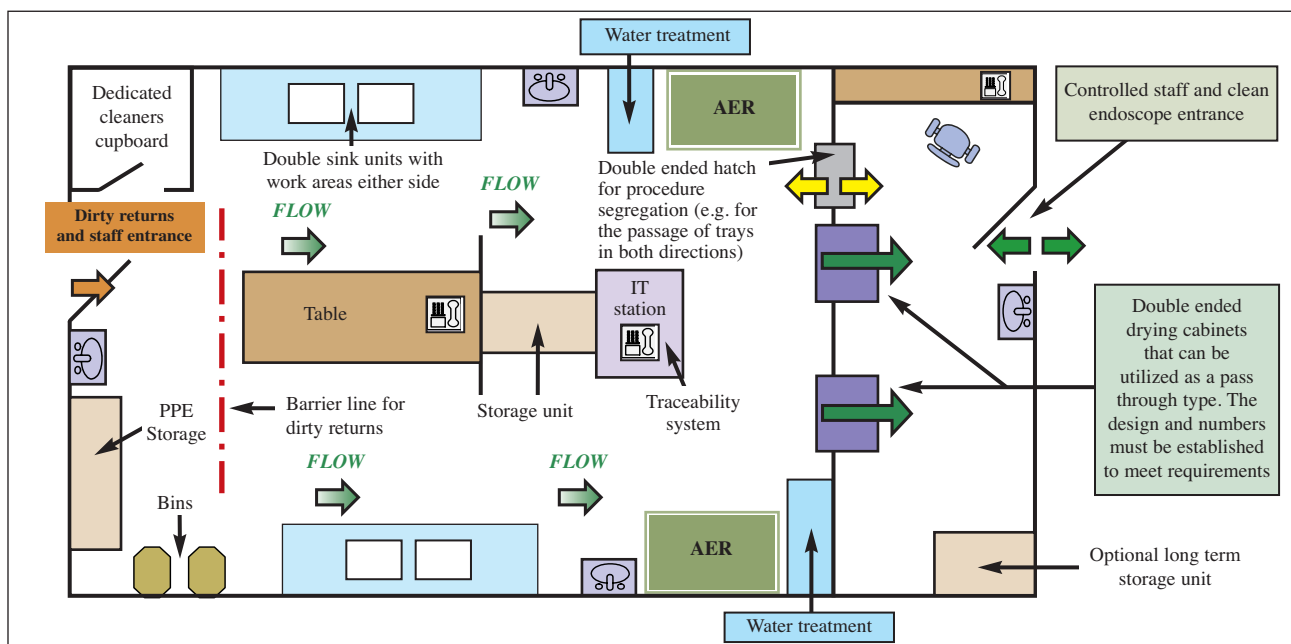

**Figure 3b: Double room decontamination unit – option 2**



there is never uncertainty about which stage of decontamination an endoscope has reached as it progresses from dirty to clean. In the design illustrated, the drying cabinet is used as the pass through facility. However, hatches could be used as the transfer mechanism. In some cases, this could be used as a typical layout but using the single room concept and have a doorway between the AER area and storage for staff to operate, especially in low staffing areas.

- 1.33 The unit shown in **Figure 4**, particularly if used as the centralised endoscope decontamination facility, represents progress towards improving standards as given in WHTM 01-06 Part A. This particular layout is divided into three sections: endoscope cleaning areas, decontaminated equipment area and drying or storage and despatch area. Double-ended AERs and double-ended drying and/or storage cabinets are illustrated, but single-ended dryers or storage cabinets could be used as an alternative. The unit includes areas for staff to put on appropriate personal protective equipment (PPE) for dirty areas and separately for clean areas, adding to the effective separation of these areas. The basis of this design is taken from the HSDU designs in WHBN 13 which have proved successful in Wales. It is a design considered to be appropriate for centralized facilities where there is high volume of endoscopes throughput.

- 1.34 The example in **Figure 5** is specifically designed with adjacent treatment areas attached to the decontamination unit. This design concept can be adapted to serve more than two adjacent treatment rooms. The design should take account of the need to ensure that used endoscope input to the decontamination area is such that the decontamination status of clean, reprocessed endoscopes is not compromised.
- 1.35 The size of the decontamination area will be determined by the demands, number and nature of procedures undertaken in the treatment rooms. The unit includes double-ended AERs and appropriate drying or storage cabinet facilities, but, provided there is a clear flow from dirty to clean, single-ended AERs can be used and appropriately designed clean transfer to the treatment areas is designed in. The layout illustrated in **Figure 5**, allows staff in two treatment areas to traverse from room to room and to take clean endoscopes as required to either treatment area. This will give total flexibility to either treatment room.
- 1.36 The drying cabinet capacity may need to accommodate all the available endoscopes for overnight storage if operational requirements so demand, that is, if reprocessing endoscopes the next morning after storage in a non-drying cabinet

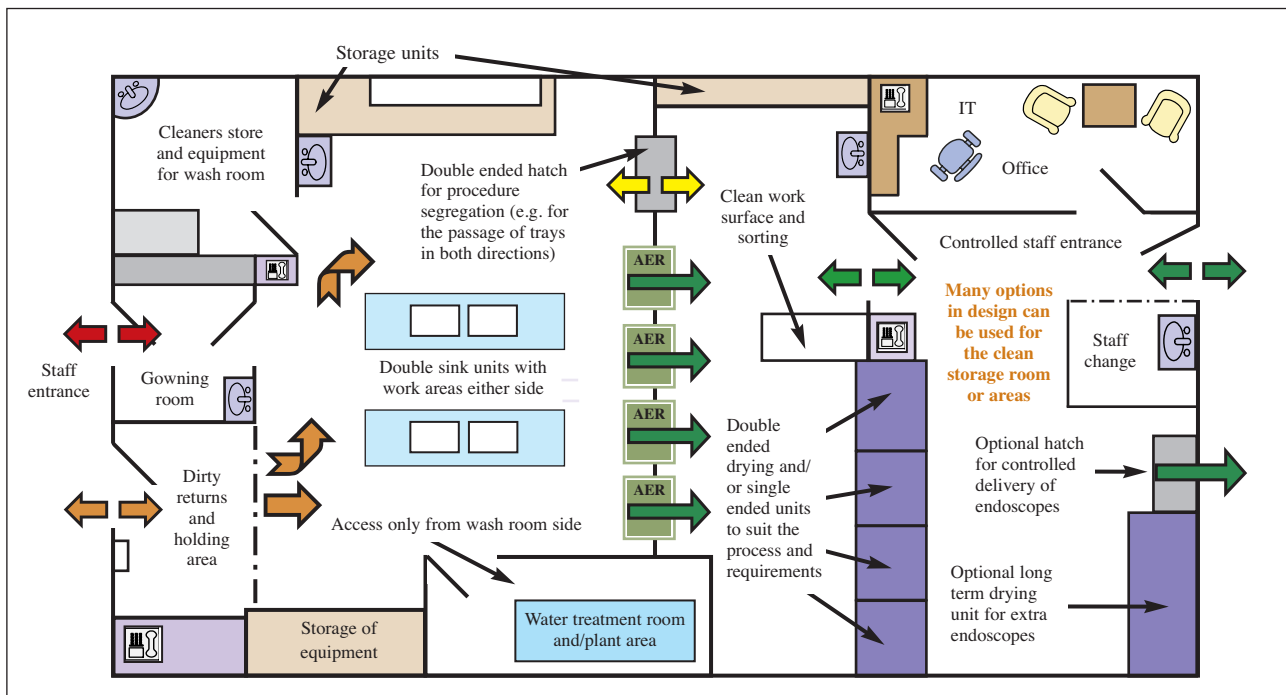

**Figure 4:** (SSD based) design for endoscope decontamination unit with clean storage facilities

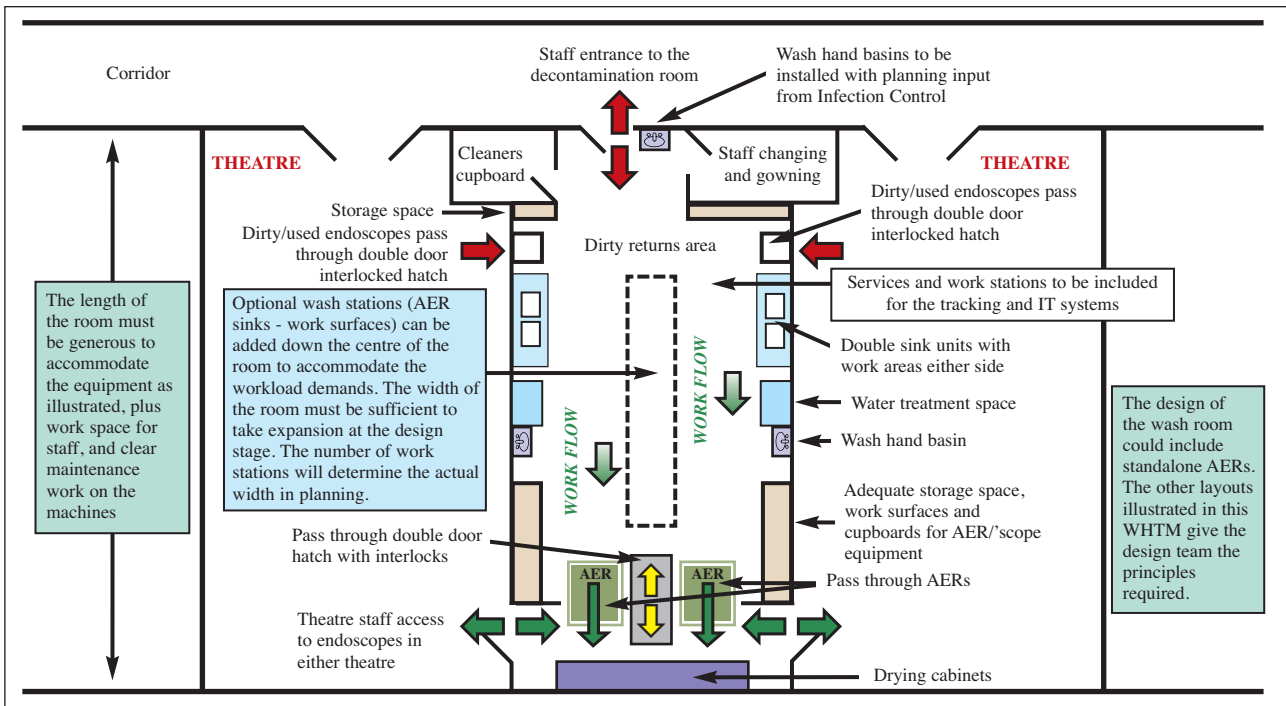

**Figure 5: Typical twin theatre design and washroom central to the process. The size of the room will be determined by the demands of the service and the numbers of endoscopes required for decontamination. Optional layouts included depending on machine selection.**

is not operationally feasible. Hatches are provided to pass used endoscopes to the decontamination area without the need for clinical staff to leave the patient unattended in the treatment room. **Figure 5** assumes that the staffing arrangements in place which allow for a dedicated decontamination team are not compromised. Some cabinets are self contained with air compressors, and a few require a separate air supply. Advice should be sought from the Authorising Engineer (Medical

Gases)(AE(MG)) on this issue as the air should not be connected to the hospital systems.

- 1.37 In all cases, the layout design should take account of the requirement at multiple stages in the decontamination and use process to record the identity of the endoscope for tracking and trace purposes ref. Refer to ‘Tracking, traceability and audit trail’ in WHTM 01-06 Part A.

### Planning notes

What will be the daily maximum throughput of endoscopes expected over the next five years?

What is the expected growth of the service?

Allow space to accommodate possible changes in design of reprocessing equipment that may be required in the future.

Consider additional factors in the possible use of the decontamination facility by other specialties (e.g. bronchoscopy, flexible cystoscopy), lumen free devices, (e.g. transoesophageal probes, nasendoscopes) and procedures performed outside the unit (e.g. in X-ray rooms or operating suites).

Based on throughput, are there enough flexible endoscopes to provide a reliable service?

From the throughput data calculate the number of AERs required.

- The time-out for weekly testing should be subtracted from the number of AER cycles available (at least one cycle per machine). Also allow for quarterly testing of up to one day and annual testing of up to three days per AER depending on the design.
- The total time for testing and maintenance may be as much as 40% of the operational time.
- The time-out for machine maintenance should be subtracted from the AER cycles available.

Allow time and throughput for faulty cycles due to all manner of reasons for failure, from incorrect loading, faulty endoscopes and machine breakdowns.





**Example of a pass through design AER**

## Design of an endoscope reprocessing unit for a local unit or small hospital

- 1.38 The problems of operating a decontamination room in a small healthcare facility have several major differences to those of larger units where there is more space and separation of defined duties. As manufacturers improve the technology, solutions may be developed that allow for storage and transport of endoscopes between health care establishments and facilities. Health Boards / Trusts should review any recent changes in technology that will allow off-site processing in larger facilities and provide alternative risk management solutions.
- 1.39 If a new unit is to be designed, the space required for patient services, waiting room, operating room and reception will form only part of the department. Space will also need to be allocated for staff changing areas, staff room, store, cleaning cupboards and offices. The decontamination area will require careful consideration to include the

items listed for large endoscopy units. Consideration should also be given to the infection control policies for the healthcare organisation concerned.

- 1.40 The principles of WHBN 13 should be used for room finishes and standards.
- 1.41 An assessment of risk from the ventilation system should be carried out and other considerations taken into account, for example, risks from lower gastrointestinal endoscopy. Refer to WHTM 03-01 Parts A and B. Particular attention should be given to ventilation requirements specified within AER and chemical manufacturers' recommendations. Where possible, ventilation systems should be configured to work within these defined recommendations.
- 1.42 It is important that the endoscope decontamination area is given sufficient space to carry out high quality work safely for both patients and staff.

### Access to engineering services

- 1.43 Accessing services behind and/or to the side of the AER and the maintenance needs of the AER should be considered. For single machines it is usually possible to move them to allow access for an engineer. For built-in AERs this facility is not available; therefore, engineering access should be designed from the dirty side of the machine. Good engineering practice should be employed and the use of flexible hoses avoided. Water treatment plant space for filters and specially designed units will also require adequate space for installation and access for maintenance.



**Endoscopes in a drying cabinet**

<b>Services and AERs</b>
<b>Water supply</b>
<ol style="list-style-type: none"> <li>1. Analyse the unit's cold water supply for hardness, conductivity, total organic carbon (TOC) and total viable count (TVC) (see <a href="#">Table 3</a> in this document and 'Total viable count' in WHTM 01-06 Part D).</li> <li>2. Water quality as supplied to the AERs needs to be risk assessed by the decontamination team and water treatment guidelines agreed for systems and needs depending on the location and use.</li> <li>3. Determine the source of the water supply - for example, local tank supply or directly from water mains; agree the levels of filtration or specialist plant required. Ensure that the water supply to the AERs meet the requirements of the water supply by-laws.</li> <li>4. Note the level of residual chlorine in the supply; this may require a carbon filter, which is important as it can destroy reverse osmosis (RO) membranes if used.</li> <li>5. Obtain water hardness and chlorine data over a 12 month period if possible, to give a guide to the processing plant required for water treatment (note: the local water supply company should be able to provide this data for water supplied to the site boundary/meter).</li> <li>6. Determine the pressure, temperature and flow of the water supply; will it match the AER requirements when all equipment is operating? (Consult AER manufacturer for design requirements or review the issued specification at purchase).</li> <li>7. Determine the treatment needed for final rinse-water (see <a href="#">Chapter 2, 'Water quality and water treatment'</a>).</li> <li>8. Determine whether the AER selected requires more than one water inlet; if so, what are the qualities and quantities required?</li> <li>9. If filtration systems are to be used, specify the material to be used and flow demands to fit the correctly sized filters and housings.</li> <li>10. If the water analysis requires a specialist water treatment unit, i.e. non RO, filtration and carbon filtration of chlorine, ensure adequate space is given and check the weight requirements for floor loading.</li> <li>11. If RO plant or similar is selected as the water treatment, where will the equipment be housed? Is there space for the water storage tank? Will the floor stand the weight?</li> <li>12. If RO water or treated water is to be distributed to several AERs, specify the type and quality of pipe material</li> <li>13. How will treated water be routinely monitored?</li> <li>14. Position of test points for water samples – ease of access.</li> <li>15. If filtration, external to the AER, forms part of the water system, how will the filters be disinfected/replaced, and how often?</li> <li>16. Conduct an audit of water supply system from point of entry to hospital to point of use, if required.</li> </ol>
<b>Drains</b>
<ol style="list-style-type: none"> <li>1. The position of drains in the floor of a room will, to a degree, dictate where the AERs can be sited. Therefore it is important to establish the ideal position for the AERs at an early stage of design to allow the drains to be sited correctly. To move drains can be a major problem, so care in their position is important.</li> <li>2. Drains from AERs should be sealed within the room and vented to the outside to prevent noxious gases entering the work area.</li> <li>3. Check that the drainpipe diameter is sufficient to carry effluent when all equipment is operating at full flow and includes spare capacity to take expansion of service or more machines.</li> </ol>
<b>Ventilation</b>
<ol style="list-style-type: none"> <li>1. Check ventilation requirements in the decontamination room, air change rates and heat load for the purposes of staff comfort, and removal of fumes or smells. (Refer to WHTM 03-01)</li> <li>2. Ventilation is probably required in the chemical storage area. (Seek advice).</li> </ol>

<b>Electrical supply</b>
<ol style="list-style-type: none"> <li>1. Is the service critical for business continuity and if so, is an essential electrical supply required and available in the area?</li> <li>2. Will a three-phase supply be required? Does the current carrying capacity of the decontamination room's electrical supply match the needs of the electrical load when all electrical equipment is working at the same time?</li> <li>3. Is artificial lighting provision in the room suitable for the tasks being undertaken?</li> <li>4. Is the lighting suitable for the environment?</li> <li>5. Is there emergency escape lighting provision in the room? Are there high risks being carried out which will affect the emergency escape lighting provision in accordance with BS 5266?</li> <li>6. Is there fire alarm provision in the unit or rooms? Is it suitable for the working and environment?</li> <li>7. Are data connections required and if so, are there suitable IT networks in the area or unit?</li> <li>8. Check the electrical services required by the AER. Does the decontamination room's electrical supply match the requirements?</li> <li>9. Are the electrical shut-off switches conveniently sited for the staff?</li> </ol>
<b>Operation for use</b>
<ol style="list-style-type: none"> <li>1. Examine the type-test data from the short-listed AER manufacturers. This will allow a fair comparison of machines (see Table 1 in 'Schedule of type tests and works tests' in WHTM 01-06 Part D 'Validation and verification').</li> <li>2. Check that access to the AER chamber will allow staff to easily operate the AER without risk to themselves, AER or endoscope.</li> <li>3. It is essential to ensure there is sufficient space around the machine for access by service engineers to carry out maintenance and testing.</li> <li>4. Check that, when making connections to an endoscope, it is easy and not prone to errors of leaking connectors or wrong identification.</li> <li>5. Can a stand-alone tracking and traceability system be connected to the AER selected?</li> <li>6. Can the tracking and traceability system selected include loan endoscopes? The 'Tracking, traceability and audit trail' section in WHTM 01-06 Part C gives suggestions on traceability records, audit history and a list of equipment required for computer tracking.</li> </ol>
<b>Space and layouts</b>
<ol style="list-style-type: none"> <li>1. For higher throughput and staffing levels use the two room option: one room for the receipt and cleaning of dirty endoscopes; the other room for the manipulation and storage of clean endoscopes. <ul style="list-style-type: none"> <li>• If the two room option is not possible due to space limitations or is not required, depending on the use, then the single room option may be considered. The following issues, however, should be considered:</li> <li>• the staffing levels</li> <li>• the design elements of flow, dirty to clean</li> <li>• the number of endoscopes to be reprocessed in a session and number of sessions</li> <li>• dirty returns area for storage and delivery</li> <li>• clean storage area and type and design of cabinets</li> </ul> </li> <li>2. Staff training is essential to underline the risks of cross-contamination during endoscope decontamination and storage.</li> <li>3. Within the decontamination area, only include the essential equipment required to clean and treat endoscopes. If possible, water-supply equipment should be housed in a separate room.</li> <li>4. Allow sufficient storage for single-use items and other spares and connectors.</li> </ol>

5. Allow for the storage of decontaminated endoscopes in a clean environment, preferably a drying cabinet.
6. Make sure endoscopes are stored securely when the unit is unmanned.
7. If electronically-generated peracetic acid is selected as the disinfection chemical, allowance may be required to house the generator in the decontamination room.
8. If RO-treated or a specialist treatment unit for the water is required, the unit may need to be installed in the decontamination room.
9. It is recommended that concentrated chemicals for the AER are stored in dedicated chemical cabinets designed for purpose, such cabinets should be positioned in an appropriate place within the facility. The organisation should carry out a COSHH assessment to ensure the chemicals are used and stored in a safe manner.
10. Position a spills kit near to the AERs, but not in the same room.
11. Work out the decontamination method for trolleys and transportation devices.
12. There should be sufficient storage space for cleaning equipment.
13. There should be sufficient space for transport trolleys and their cleaning regimes.
14. There should be sufficient hand wash facilities in all relevant areas. Consult the infection control team.
15. There should be staff changing facilities and PPE changing.
16. There should be storage for the endoscopes drying cabinets, ensuring good access.
17. Air compressors need space for some designs of drying cabinets. Check requirements and plan the space if they are required. Compressors should be correctly specified, fit for purpose and oil free.

**Table 2: Checklist of engineering considerations when setting up a new endoscope reprocessing unit or upgrading an existing room (this table should be read in conjunction with Chapter 3, 'Engineering services')**

#### Note

It is essential to consider exposure limits and COSHH regulations for individual chemicals used during both the manual and automated processes when planning/designing a new decontamination unit or refurbishing an existing one. Additionally, consideration should be given to possible ventilation system upgrades as a result of future changes in process chemicals resulting from manufacturers compatibility or equipment replacement programmes.



# Chapter 2 Water quality and water treatment

## Summary

The role of water use during the processing of flexible endoscopes is covered in this section. In particular, the quality of the final rinse-water is discussed in detail with recommendations for the upper limits of certain chemicals, organic matter and bacteria. Guidance is given on water treatment options, depending on the water source. As water storage and biofilm have a great influence on the quality of the final rinse-water, guidance on these subjects is included.

Where a service is provided for a broad range of clinical applications, risk considerations should reflect **hazard** to the most at-risk patient group.

Water supplies in all healthcare premises and actual locations in each building can differ and fluctuate. Hence there is a real need to monitor the supply on a constant basis.

## Water quality

2.1 Water is used for several purposes in an AER:

- initial rinse-water;
- intermediate rinse-water;
- final rinse-water;
- as a diluent for chemicals.

### Initial and intermediate rinse stages

2.2 For acceptable hardness levels, see [Table 3](#).

2.3 The intermediate rinse stage between cleaning and disinfection may be omitted if the disinfectant and cleaning agents are known to be compatible and the disinfectant preparation is used only for a single cycle.

2.4 The quality of the intermediate rinse-water is not as critical as the final rinse; therefore the AER may have a separate water inlet for this grade of water. It is important during installation to make sure the correct grade of water is supplied to the correct connection on the AER.

2.5 Hardness may be an important parameter when examining water supply to the rinse stages. The manufacturer's specifications should be consulted

for the detergent to be used. The advice of the water supplier should be sought, where appropriate.

### Final rinse-water

2.6 The grade of water used for the final rinse should be high; as some residual water from a reprocessed endoscope can be transferred into the patient if the endoscope is used within the 3 hour rule and not effectively dried out (endoscopes are not dry at the end of an AER cycle unless stored in a drying cabinet). Therefore any residual water should not harm the patient. This is important in terms of ensuring a satisfactory patient experience of care. For practical purposes, the levels of contaminants described for potable water are sufficient unless an endoscope is to be used in a normally sterile area of the body. Therefore the final rinse-water should not contain any harmful chemicals or organisms. [Table 3](#) in this document and [Table 2](#) in WHTM 01-06 Part E 'Testing methods' give details of the maximum levels of specific chemicals and organisms suitable for final rinse-water. The level of purity is also described in BS EN ISO 15883-1.

### Note

Final-rinse residual water could be present when samples are taken. If this water is contaminated with environmental mycobacteria, these organisms will appear similar to *Mycobacterium tuberculosis* in tissue and may cause misdiagnosis.

### Chemical process residues

2.7 The level of chemical process residues may be of concern depending on the chemical additives and quality of water used during the cycle. Flexible endoscopes come into contact with mucus membranes or internal body tissues during use. In addition, if hard final rinse-water is used, this may damage the AER and the flexible endoscope. Compatibility statements for use by the AER and endoscope manufacturer should be obtained for any chemicals used and validated to the process. Any changes must be revalidated and agreed by all the manufacturers concerned.

- 2.8 The chemical additives used during the process, detergents, etc., may not be completely removed by the rinsing process. The residual level that may be tolerated will depend upon the nature of the chemical. The supplier of any chemical agent used should provide data on the composition of the chemical agent and the biocompatibility of components of the chemical agent. Suppliers should also provide details of the detection method used to determine whether processed items are free from residuals at the specified levels.
- 2.9 Some AER process cycles add disinfectant to the final rinse-water to kill any contaminating organisms. The level of disinfectant at this stage should be shown to be non-toxic to patients. In addition, the AER manufacturer should supply data detailing a neutralising chemical that will neutralise the disinfectant ready for microbiological analysis. The sample of the final rinse-water quality should be as shown in [Table 3](#).

#### *How is quality achieved?*

- 2.10 Two of the most commonly used methods of providing water of the quality required for the final rinse are RO or other high quality filtration methods depending on the results obtained. Where active processes are used, it is important that these are monitored and the equipment is correctly maintained at regular intervals, as recommended.
- 2.11 The nature and extent of treatment will depend in part on the quality of the local water supply. Therefore when a new installation is being planned, analysis of the water supply will provide a useful guide for the plant and equipment required to treat the water (see [Figure 6](#)) and may include at least the following steps and options:
- water softeners (these will require great care and monitoring);
  - pre-filtration to remove larger particulate matter;
  - pre filters may require one or two filtration stages depending on the quality of water supplied, but the final stage should be with a filter that will retain particles of 5 µm or larger (see [Table 3](#));
  - filtration through pre-filter and a bacteria-retentive filter (0.22 µm);
  - water deionisation;
  - RO (reverse osmosis water);
  - specially designed high level filtration unit designed for the application, including carbon

filters for high levels of chlorine, especially if tank water is used as a feed;

- addition of non-toxic disinfectant (dosing system);
  - It is essential that maintenance of the installed system is carried out as illustrated by the manufacturer based upon local conditions. The potential for impurities within the water supply will be increased if such regimes are not adhered to.
- 2.12 For filtration, the operating system may include means to:
- monitor the integrity of the filter or warn of failure, for example, measurement of pressure differentials;
  - disinfect the filter and the downstream water distribution system at the start of the working day. In addition, self-disinfection should be set up on the AER to occur using a timer during periods when the AER is not used. This should preferably be by exposure to moist heat;
  - clean and disinfect filter housings and pipe work during routine filter changes;
  - maintain the filter with a constant flow of water (not left wet in static water);
  - inhibit microbial growth in water in the storage and distribution system downstream of the filter;
  - measure the addition of disinfectant, if used.
- 2.13 Owing to pressures on water resources, water supply companies may vary the source of water abstraction or alter the distribution supply network; therefore, analysis of water supplied over time should be obtained to ensure the range of water quality likely to be encountered can be determined. The sampling point should be as close to the endoscope decontamination site as possible.
- 2.14 If heated water storage is used, it will be necessary to cool the water supplied to the AER to ensure that the endoscopes are not damaged by exposure to too high a temperature (above 60°C).

#### **Water used to dilute chemicals**

- 2.15 The grade of water used to dilute chemicals in an AER should not affect the efficacy of the chemicals. Detergent, when diluted, should provide a good cleaning effect. Disinfectants, when diluted, should kill contaminating organisms. The hardness level shown in [Table 3](#) should be used as guide for this purpose.

## Key factors affecting the quality of water

2.16 Knowledge of the mains water characteristics supplied to endoscope decontamination units can be very useful. In many modern hospitals the water may be supplied via a storage tank. It is very possible that this tank could give rise to high bacterial numbers or high chlorine levels. The tank system will need monitoring as cleaning regimes need to be in place to ensure that the supply is as clean as possible. The design of tanks can lead to the water being stagnant below the water take off pipes. If water treatment is planned for the endoscopy unit, these properties can be allowed for.

Where it is known that there is a risk of stagnation in supply, appropriate treatments systems can be installed providing dosing is monitored, controlled and does not interact with process chemicals. In areas where the mains water is of good quality, and the supply to endoscopy units is taken from the incoming main, it is essential to have minimal take off points or services, and no dead legs. The distribution system should be engineered to maintain a frequent flow of the water supply.

Local assessment should verify which is the best supply/purification system based upon historical properties and results within each water supply.

- 2.17 The number, nature and quality of water supplies required are dependent on the size and type of AERs.
- 2.18 The quality of water (see [Table 3](#) of this document and Table 2 in WHTM 01-06 Part E ‘Testing methods’) used at all stages in the decontamination process is critical to the successful outcome of the process. Factors include:
- water hardness;
  - temperature;
  - ionic contaminants, for example, heavy metals, halides, phosphates and silicates;
  - microbial contamination;
  - water deposits;
  - bacterial endotoxins;
  - TOC.

### Water hardness

- 2.19 Hard water is caused by the presence of dissolved salts of alkaline earth metals, principally calcium, magnesium, barium and strontium, which have low solubilities. Although a guide level of calcium equivalent is given in this document, additional data will be required to determine if use of a particular water supply will result in deposits forming on processed items. Many detergents and disinfectants are seriously impaired in their activity by hard water (see [Table 3](#)).

Application	Requirements
Initial flush	Hardness less than 200 mg/L CaCO <sub>3</sub>
Intermediate flush	Hardness less than 200 mg/L CaCO <sub>3</sub>
Water for diluting disinfectants and detergents	Hardness levels to manufacturers’ data
Final rinse-water (These figures are for when RO water is used for final rinse)	Hardness less than 50 mg/L CaCO <sub>3</sub> TOC less than 1 mg/L Conductivity less than 40 µS/cm, unless disinfectant added
<p>Note: If any of the above parameters for the final rinse-water are above the stated limits, additional water analysis will be required to determine the source of the problem, for example, pH, chloride, heavy metals.</p> <p>The criteria and parameter limitations for other contaminants including salts not listed in this Table should accord with the rolling revision of the World Health Organisation’s ‘Guidelines for drinking water quality’. In light of the use of variable supply quality through the recently established national water grid, it is appropriate for providers to periodically discuss this issue with their water supplier.</p> <p>Tests for <b>hardness</b> and <b>electrical conductivity</b> are detailed in the WHTM 01-06 Part E.</p>	

**Table 3: AER water chemistry requirements - The figures shown will be based upon local conditions, chemicals used and AER manufacturers’ technical specification.**

- 2.20 Using hard water in the final rinse stages of an AER cycle is one of the major causes of deposits on load items. These deposits are not only unsightly and an unwelcome contaminant, but act as a focus for soiling and recontamination of the item in use. Such deposits may seriously impair the utility of the endoscope, particularly the optical system. Hard water may cause scaling on the edges of spray nozzles even when fed with only cold water. Detergent formulations intended for use only with soft water may give rise to precipitation if used with hard water. If these products are used diluted with hard water in an AER, serious damage to endoscopes may result.
- 2.21 The presence of hardness salts in water seriously impairs the efficiency of most detergents and disinfectants. If the use of hard water is unavoidable, it will be essential to use process chemicals that contain sequestering agents. This adds considerably to the cost of the process.

#### Note

Some AERs are fitted with integral water treatment systems that are designed to keep the fittings hygienic and the water clean.

#### Temperature

- 2.22 The temperature at which water is supplied to each stage of the process has a major effect on the efficacy of the process. Water at too high a temperature during the initial flushing stage may lead to the coagulation of proteins and thus serve to “fix” proteinaceous soil to the surface of the load items. The inflowing water should be maintained at a temperature lower enough to preclude the occurrence of protein coagulation.
- 2.23 Water for the initial flushing stage should be supplied from a cold supply. Many AERs will shut down if the supply water approaches 30°C. Water for other stages may be supplied from a different source and may be warm when the cycle has an elevated temperature stage. AER and process chemical manufacturers will advise on the temperatures required for the detergent and disinfectant, based upon both type test information and performance qualification data produced during installation.

Caution should be adopted if heated or warm water is to be supplied to an AER. As a requirement, it should be generated as close to the AER as possible to avoid bacteria from tanked service biofilms. Good engineering practice should be used to ensure a good design to minimise the risks.

- 2.24 The activity rate of chemical disinfectants generally increases with increased temperature. Water at too low a temperature during the washing stage of the cycle will often impair the ability of detergents used to remove soils composed largely of fats, oils or grease, and will cause failure to achieve the required microbial inactivation. However, too high a temperature with particular compounds can lead to degradation of the active components, evolution of toxic vapours or damage to the endoscopes being processed.
- 2.25 The maximum temperature of rinse-water should be compatible with the items being processed; flexible endoscopes are temperature-sensitive and may be damaged by temperatures above 60°C.

#### Ionic contaminants

- 2.26 Water used in the cleaning and disinfection of flexible endoscopes should have a chloride concentration between 0 and 120 mg/L chlorine to avoid the risk of corrosion. Chloride concentrations greater than 240 mg/L can cause pitting of some stainless steel and plastic components.
- 2.27 Water used for the final rinse should have a chlorine level no higher than 10 mg/L. Chlorine levels exceeding this level should be reduced using a carbon filter. In some AERs, a chlorine compound is added to the final rinse-water to prevent microbial contamination.
- 2.28 A measure of the ionic contamination of water can be gained by the measurement of conductivity (Table 3). If it is suspected that specific chemicals may contaminate the water source, other tests for individual compounds should be carried out.
- 2.29 For final rinse-water that contains a disinfectant, conductivity may be greater than 40 µS/cm. Guidance from the manufacturer will be required to ensure damage to flexible endoscopes does not occur with multiple use.
- 2.30 Some AERs incorporate a disinfectant that will have a chloride concentration greater than 120 mg/L. Assurance from the manufacturer should be obtained regarding materials compatibility, both for the AER and the endoscopes in use.

#### Microbial contamination

- 2.31 The purpose of the decontamination process is to remove soiling and reduce the microbial contamination to an acceptable level for the intended use of the items to be processed. The



water used at each stage of the AER process cycle should not increase the bioburden of the load items.

- 2.32 Flexible endoscopes are used without further decontamination processing. The nature and extent of the microbial contamination in the final rinse-water should not present a potential hazard to the patient, either through infection or by leading to an erroneous diagnosis (see [Table 3](#)). Appropriate treatment to control or reduce the microbial contamination in water may be required (see [paragraph 2.44](#), ‘[Water treatment options](#)’).

### Deposits from water

- 2.33 Mains water may well contain deposits originating from the water treatment plant or distribution system. Water used in an AER should be clear and colourless.
- 2.34 Water deposits should be removed by filtration; otherwise they may affect endoscope cleaning and disinfectant efficacy and leave deposits inside endoscopes on completion of the process cycle.
- 2.35 Pre-treatment should be used where required to protect RO units.

### Bacterial endotoxins

- 2.36 Bacterial endotoxins are thermostable toxic compounds derived from the cell walls of bacteria which, when introduced into the human body, can cause a fever-like reaction and other adverse effects. They are not readily inactivated by chemicals or removed by bacteria-retentive filters. Control of endotoxin exposure is important to outcomes and the care experience.
- 2.37 AER final rinse-water should not contain more than 30 endotoxin units/ml. above this level there is a small risk that the toxin may affect the patient after some procedures. Routine endotoxin testing is therefore not required unless there is evidence of a major water supply problem indicated by the TVC and TOC results (see [Table 3](#) in this document and [Table 2](#) in [WHTM 01-06 Part E](#)).
- 2.38 The identification of bacterial species is advised and the results presented to the microbiologist or infection control doctor for consideration. This information may aid identification of the contamination source and assist with any subsequent advice. The presence of *Pseudomonas* spp. may have direct patient-health implications (see note to [Table 2](#) in [WHTM 01-06 Part E](#)).
- 2.39 For endoscopy procedures that require very low bioburden final rinse-water, for example,

endoscopic retrograde cholangiopancreatography (ERCP), a risk assessment is recommended.

### Total organic carbon (TOC)

- 2.40 Where the risk assessment indicates TOC testing be used as a risk control indicator for the predisposition of a biofilm formation, testing will be required at intervals determined by the local decontamination group and by the results of a local risk assessment.
- 2.41 If the AER’s self-disinfection cycle is demonstrated to be effective, for example, by TVC monitoring, TOC testing can indicate the presence of a biofilm but the quantities measured may not be indicative of an actual problem. The frequency and need of the test can be determined by the consistency of the localised water supplies, any reported anomalies, e.g. excessive requirements for filter changing, chemical foaming during cycle or consistent TVC failures (see [paragraph 2.66](#), ‘[organic purity](#)’) Advice can be sought from the Microbiologist, NWSSP-FS or testing laboratories.

### Legionella and *Pseudomonas aeruginosa*

- 2.42 The presence of legionella in the final rinse-water of an AER is very unlikely, but possible. Legionella are normally found in contaminated water in association with other organisms and the presence of biofilm. The laboratory detection of legionella is in the order of 100 legionella per litre; therefore, at least a 1 L sample is required by the test laboratory.
- 2.43 Subject to risk assessment, testing the final rinse-water for legionella may not be required. If the detection of legionella is considered necessary, the method described in [WHTM 04-01](#) – ‘The control of Legionella, hygiene, ‘safe’ hot water, cold water and drinking water systems’ should be applied.
- 2.44 *Pseudomonas aeruginosa* has been reported to colonise some taps both in wash-hand basins and sinks used for cleaning or general tasks (See [WHTM 04-01](#): ‘Addendum *Pseudomonas aeruginosa* – advice for augmented care units’).

### Water treatment options

- 2.45 There are generally six methods of water treatment available for use on water supplies to be used in AERs. These can be used as individual treatments or in combination:
- water softeners;
  - water deionisers;
  - distillation;

- RO (reverse osmosis);
- filtration;
- disinfectant addition.

### Water softeners

- 2.46 Water softeners, or “base-exchange” (ion exchange) softeners, consist of an ion exchange column containing a strong cation resin in the sodium form. Calcium and magnesium ions in the water are replaced by sodium ions. The column may be regenerated by treatment with a solution of common salt (sodium chloride). These units allow bacterial growth so may cause a significant increase in the microbial content of the water.
- 2.47 Sodium salts, which remain after softening, do not readily form hard deposits to foul heat exchangers or spray nozzles, but if used as the final rinse, they will leave white deposits on the load items as they dry.
- 2.48 Water softeners are simple to operate with an automated in-line system, will handle water with varying levels of hardness, and are safe to regenerate. After regeneration, however, high levels of chloride ions may be present in the initial output from the softener, which should be run to waste.

#### *Integral water softener*

- 2.49 AERs are available with built-in base-exchange water softeners. Water softeners should be chosen based on the total demand of softened water in the unit.
- 2.50 In common with other water treatment systems, the base-exchange softener needs to run to a minimum volume of outflow if the required water quality is to be achieved. The manufacturer of the treatment plant should specify this volume. The output from the softener should be to a water tank, and the volume demanded each time additional water is fed to the tank should exceed the minimum flow (see WHTM 04-01 for guidance on water storage).

#### Note

**Good engineering design and understanding of the requirements are required as these softeners can be a cause of bacterial growth if installed incorrectly and not tested and managed on a regular basis.**

### Water deionisers

- 2.51 Deionisation or demineralisation systems can remove virtually all the dissolved ionic material by ion-exchange using a combination of cation and anion exchange resins either in a single column (mixed bed) or in a separate column. Their use for

treating the final rinse-water of an AER is not recommended.

- 2.52 Operating costs of mixed bed deionisers are usually higher than those for two-stage systems.
- 2.53 Routine maintenance (regeneration) of deionisation and demineralisation systems requires the use of a strong acid (hydrochloric acid) and a strong alkali (sodium hydroxide). For most types of installation, an exchange column service is available from the water treatment suppliers. The maintenance of these systems in line with the manufacturer’s requirements is essential to safeguard output quality.
- 2.54 Deionised water may become contaminated with microorganisms and the resin column colonised. Deionised water should not be used for the final rinse of products intended for invasive use without further decontamination processing by heating, filtration, etc. It is essential that a risk assessment in this area and related local policy establish a safe water supply appropriate for each stage of the process.
- 2.55 For a given output volume, the initial cost of providing deionisation equipment will be lower than for RO. However, the inconvenience and cost of the regeneration process for deionisers, and the better microbial quality of the RO process, makes it the preferred option.
- 2.56 The use of deionisation for AER water is not common, since AERs are only suitable for a water supply low in inorganic contaminants (otherwise the exchange or regeneration of cartridges is too frequent).

### Distillation

- 2.57 Distilled water may equal or exceed the purity of RO water but, despite the relatively low capital cost of the necessary plant, is very expensive to produce due to the high energy usage.

### Reverse osmosis (RO)

- 2.58 RO treatment plants remove almost all dissolved inorganic contaminants by passing the water, under pressure, through a semi-permeable membrane against an osmotic gradient. The process will also remove a high proportion of organic material, bacterial endotoxins and microorganisms. Some RO units are fitted with a final 0.2 µm filter to control bacterial numbers.
- 2.59 The initial capital cost of an RO plant is generally higher than for a deionisation system supplying a similar volume of water, but operational costs are lower. The water has a low TOC level and

microbial population. Measures are required to maintain the microbial quality of water during storage and distribution. The retention of this water quality requires a high level of understanding and maintenance.

2.60 The wastewater produced by properly RO plant may be designated as grey and reused appropriately.

2.61 Issues to be considered when installing RO systems include:

- The system removes bacteria, endotoxins and approximately 95% of chemical contaminants.
- The system and associated pipework needs to be sanitised regularly.
- The system provides processed water over a long period with minimal maintenance.
- Routine maintenance and membrane replacement are very important.
- The system provides water quality suitable for diluting AER chemicals and final rinse.
- The system usually requires a carbon filter to be fitted ahead of the RO unit to remove traces of chlorine from the water supply.
- RO units use large volumes of water, much going to waste, which can be used as grey water.
- Selecting an RO system will depend on the geographical area of the water source and its quality (see [Figure 6](#)).
- If the supply water is hard, a softening system will be required ahead of the RO unit.
- Water storage is required, as RO units supply moderate volumes of water over a long period. AERs need large volumes of water quickly during various stages of the cycle.

### Filtration

2.62 When water is treated by filtration, for example, through a 0.22 µm filter to remove microbial contaminants, rigorous controls are needed to ensure that the system works effectively. This should include:

- either maintaining the pressure drop across the filter throughout its working life – a decrease in differential pressure being cause for rejection of the process cycle and a change of filter – or a bubble point test (see BS 1752, ISO 4793). In the event of concerns in this area, a service agent should be consulted;
- a continuous recirculation system for RO water supplies. For a bank of filters, intermittent

chemical disinfection is appropriate to prevent a bioburden build-up;

- treatment of the circulating water to ensure that proliferation of microbial contamination is inhibited either by use of elevated temperature, for example, greater than 60°C, filtration through a suitable fine filter or by ultraviolet irradiation (wavelength 260 ± 10 nm; >2 J/m<sup>2</sup>) or chemical biocide.

### Note

Ultraviolet irradiation will only kill planktonic microbes; it has little effect on biofilm.

### Disinfectant addition

2.63 If a chlorine-based disinfectant is used, some providers are allowing a non-toxic disinfectant to be present in the final rinse-water (see the 'Process chemicals' section in WHTM 01-06 Part C). Confirmation is required to show these chemicals, in the concentrations used, are not toxic to the patient. Residual chlorine remaining in a reprocessed endoscope may reduce the possibility of biofilm formation and growth of contaminants.

### Water treatment plant

2.64 Despite the cost involved, treating water from the public supply is usually cost-effective. It is important that any water treatment plant is designed to be self-disinfecting with a system built-in to pump disinfectant around the complete treatment circuit on a regular basis, for example, during the AER's self-disinfection stage. A 5 µm filter should be fitted as a pre-treatment before an RO unit.

### Backflow prevention

The water supplied and distribution system to the AER should comply with the Water Fittings (Water Supply) Regulations and BS EN 1717.

### Note

Ensure that the type A air gap in line with the water regulations is integral with the AER when purchasing as part of the design. If the AER is not fitted with a type A air gap, then it is a requirement to fit one in the water supply line to the machine(s). This may lead to extra monitoring of the system as remote tanks/air gaps can lead to further growth in the system. It is recommended that such an air gap system is installed as close to the wash room as possible with easy access for cleaning and dosing if and when required. Fully check the water systems and zones for backflow protection.

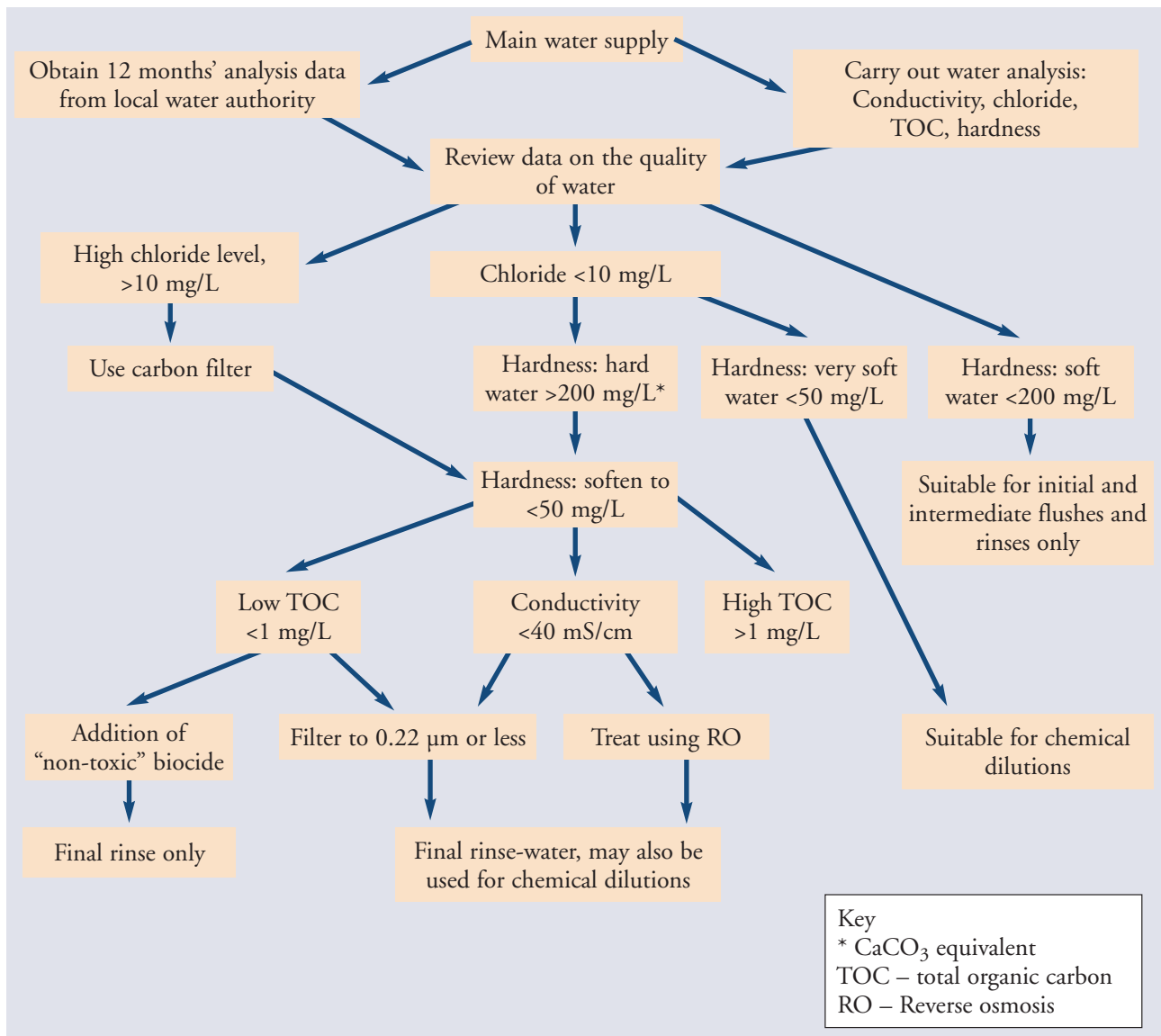

Figure 6: Selection of water treatment systems for AER final rinse

## Tests for purity levels

### Chemical purity

2.65 The chemical purity of water used in an AER is not critical as long as the quality is better than that of potable water with a hardness level below 200 mg/L CaCO<sub>3</sub>, except for chemical dilutions and final rinse where a maximum hardness of 50 mg/L CaCO<sub>3</sub> is acceptable. To determine whether the water supply is suitable for an AER's final rinse-water, a conductivity test is suitable (see paragraph 2.16, 'Key factors affecting the quality of water'). Where elevated process temperatures are used, particular care should be taken over contaminant levels; the equipment manufacturers should be consulted.

### Organic purity

- 2.66 Organic compounds dissolved in water may cause a problem, if in high levels, when mixed with detergents and disinfectants. In particular, high levels of organic compounds can cause a detergent to foam, reducing its cleaning effect.
- 2.67 A general measure of dissolved TOC is useful as a guide to water contamination. Organic compounds may be present in water at source due to the supply catchment area. In addition, organic compounds will be added to water if filters become overgrown with organisms. **Therefore, a TOC test can provide a useful guide to the state of the final rinse-water: a maximum TOC of 1 mg/L is acceptable.**

### Microbial purity

- 2.68 Potable water from the public supply has a low microbial content and has a requirement to be free from pathogenic organisms as it enters the premises, but may contain organisms that could cause opportunistic infections in immunocompromised patients if allowed to grow to high numbers
- 2.69 The microbial content may increase considerably in intercepting tanks and cisterns.
- 2.70 Attention is drawn to the requirement under the Health and Safety Executive's Approved Code of Practice and guidance on legionella (L8 and HSG 274 Part 2) that water in intercepting tanks (not RO holding tanks) should be stored below 20°C or above 60°C (see also WHTM 04-01)
- 2.71 Water stored at 60°C or above may be assumed not to have a proliferating microbial population.
- 2.72 AER final rinse-water should be provided by a water treatment system that generates bacteria-free or sterile water. A small volume of this water may remain in the endoscope at the point of use. Just before use, a surgeon may inject the endoscope with sterile water before starting a procedure to confirm all the lumens are clear.

### Pipework

- 2.73 The design of the pipework, tanks and sanitary fittings should avoid dead-legs and an area where microbial growth may proliferate is critical to the maintenance of the system from microbial contamination (see WHTM 04-01).
- 2.74 Pipework used to supply the various grades of water should be appropriate to the quality of water carried. Stainless steel or copper pipes or fittings are preferred for all qualities of purified water (see BS 6920-2.4).
- 2.75 Fittings and pipe connectors used to deliver the final rinse-water should have minimal dead space and be drained at the end of the process cycle.
- 2.76 The pipework, valves and pumps through which final rinse-water will pass should be subjected to an appropriate frequent sterilization/disinfection process. This is normally achieved by self-disinfection carried out daily.
- 2.77 Certain types of plastic pipe and tank material may, when first installed, give off organic carbon. Joining compounds used on some plastic pipework may also give a rise in TOC levels. Therefore, TOC measurements on new installations should be repeated over the commissioning period.

- 2.78 The growth of organisms in water is enhanced by the presence of organic carbon, which is used as a nutrient source. Biofilm (see [paragraph 2.80, 'Biofilm formation'](#)) often forms on plastic surfaces due to the presence of carbon.
- 2.79 For pipework and tanks, stainless steel is preferred for this reason. Some systems add biocide to the rinse-water, which will control bacterial growth and the development of biofilm (see [paragraph 2.80, 'Biofilm formation'](#)).

### Biofilm formation

- 2.80 Biofilm is a layer of growth that forms due to organisms sticking to solid surfaces.
- 2.81 *Pseudomonas* spp. are a common finding in AERs. If allowed to form, a layer of growth of other organisms will grow over the top of *Pseudomonas* spp., increasing the thickness of the biofilm. Biofilm can be present over the long term and is very adherent to the surface on which it forms. The removal of biofilm takes considerable effort and may require the use of aggressive chemical agents and physical means.
- 2.82 Biofilm can form in the crevices of valves and pipe junctions, particularly plastic. Therefore, the inside of an AER should have no dead spaces where biofilm can form. A delay in delivery of an AER after manufacture and testing will allow biofilm to form within the machine. This may require the replacement of all the flexible pipework when first commissioned to allow the bacterial count in the final rinse-water to pass microbiological tests.
- 2.83 The addition of a non-toxic biocide, under controlled dilutions, to the final rinse-water may help prevent the formation of biofilm.

### Water supply regulations and services

- 2.84 See WHTM 04-01 and [Chapter 3 'Engineering services'](#).



# Chapter 3 Engineering Services

## Summary for all Health Boards / Trusts and healthcare establishments

The engineering aspects of each service supplied to an AER are discussed in this chapter. In addition, guidance is included on the particular aspects of these services that apply to AER installation, operation and maintenance. Attention is drawn to the information provided by AER manufacturers on the engineering services required for AER operation. Guidance is also provided on ventilation, both in the decontamination suite and in relation to the AER.

Quality inspectorates should ensure that sound arrangements are in place to ensure servicing in keeping with the guidance provided here.

- 3.1 An AER will require the following services: electricity, water, drainage, ventilation and chemical additive (detergent, disinfectant, etc.) supply. Exceptionally, clean positive pressure air supply may be needed. The manufacturer's product data sheets will show which services are required for each model. It should be determined which of these are available at the proposed site and the capacities of each service. It may be necessary to plan for a new service, which would add significantly to the cost of the installation.
- 3.2 The manufacturer should make clear at an early stage which services will be needed and give detailed requirements for each service (see [Table 4](#)).
- 3.3 For most AERs, the water and drainage services are the most critical although for User comfort and safety the ventilation and extraction system are also important.
- 3.4 If the services are to be installed by a contractor, other than the contractor installing the AER, care should be taken to ensure that the size and location of terminations are agreed before the contracts are placed.

## Ancillary equipment

- 3.5 Ancillary equipment, for instance water treatment plant, should whenever practicable be installed and

commissioned before validation of the AER begins.

- 3.6 When the checks on ancillary equipment require the AER to be in operation, the Competent Person (Decontamination) (CP(D)) should carry them out in cooperation with the contractor for the AER.
- 3.7 The contractor for the AER is not responsible for the correct functioning of services and ancillary equipment unless this was agreed in the purchase contract.

## Water services

- 3.8 Water supplies to the AER may be derived from:
  - mains water supply;
  - the healthcare facility's header tank supply;
  - the healthcare facility's softened supply;
  - local softened water supply;
  - RO water supply.

For general water supplies for use in a department refer to the Chief Medical Officer's letter, CMO(2010)13 Water sources and potential for cross infection from taps and sinks.

- 3.9 It is important that the organisation responsible for the AER water supply is known. Any problems found during installation or operational tests due to the water supply need to be resolved quickly, otherwise commissioning could be delayed.
- 3.10 An analysis of the supply water quality should be carried out at an early stage of upgrading or when designing a new installation (see [paragraph 2.1, 'Water quality'](#)). A request for a copy of the water analysis report from the local water supply company may give the water quality data required. From this data, the design of the water treatment plant can be made (see [Figure 6](#)). If water supplied to an endoscopy department is stored within the building and treated locally before distribution, information on this treatment will be needed from the estates and facilities department. In addition, knowledge of the supply pipe layout would be useful to determine whether any dead-legs are present.

Electrical supply
<ol style="list-style-type: none"> <li>1. number of phases (normally one or three) and whether neutral is required for a three-phase supply;</li> <li>2. supply voltage and frequency including nominal and acceptable minimum and maximum values;</li> <li>3. maximum continuous power demand in kilowatts (kW) or kilovolt-amperes (kVA);</li> <li>4. recommend protective device size and type;</li> <li>5. data connection provision required.</li> </ol>
Water
<ol style="list-style-type: none"> <li>1. the acceptable range of supply pressures;</li> <li>2. the flow at minimum pressure;</li> <li>3. the volume used per cycle;</li> <li>4. the acceptable temperature range for incoming water (see <a href="#">Chapter 2 'Water quality and water treatment'</a>);</li> <li>5. confirmation that the supply water is of potable standard (possibly carried out by a third party (see <a href="#">Chapter 2, 'Water quality and water treatment'</a>));</li> <li>6. the quality of water required when relevant – the maximum permissible hardness expressed as mg/L CaCO<sub>3</sub> (see <a href="#">Chapter 2, 'Water quality and water treatment'</a>);</li> <li>7. the acceptable range of pH (see <a href="#">Chapter 2, 'Water quality and water treatment'</a>);</li> <li>8. the maximum permissible conductivity (see <a href="#">Chapter 2, 'Water quality and water treatment'</a>);</li> <li>9. the maximum acceptable microbial population (see <a href="#">Chapter 2, 'Water quality and water treatment'</a>).</li> <li>10. the maximum flow of effluent to the drain;</li> <li>11. the maximum temperature of the effluent on leaving the AER;</li> <li>12. the maximum effective diameter of the discharge orifice from the AER chamber; the drain and associated system should be sealed to prevent aerosols, splashes, droplets and vapours being released into the room.</li> </ol>
Ventilation
<ol style="list-style-type: none"> <li>1. if the AER uses thermal self-disinfection, the peak value during a cycle and the average value throughout a cycle of the heat (in watts) transmitted to the environment when the AER is operated in still air at an ambient temperature of 23 ± 2°C;</li> <li>2. ventilation requirements for removal of fumes or gases from hazardous chemicals used in the process;</li> <li>3. for double-ended AERs, air passage between wash room and clean room, via openings around the AERs, should be minimised to limit pressure loss if there is a differential pressure between the wash room and clean room.</li> </ol>

**Table 4: Information on services to be obtained from the AER manufacturer**

- 3.11 Some water authorities require a Class A air gap for water supplied to medical devices, even if the water is fed from the healthcare facility's main tank.
- 3.12 AERs may be supplied with both hot and cold water. When warm water is required as part of the operating cycle, it is generally advantageous to supply hot water to the AER to dilute with cold water for use, rather than heat cold water to the required temperature within the AER, as this may reduce cycle time. The quality of water used at all stages in the decontamination process is critical to the successful outcome of the process.
- 3.13 General guidance on AER water supplies is given in [Chapter 2, 'Water quality and water treatment'](#). (See also [Table 2](#) for a checklist on water supply).

### Electrical services

- 3.14 The electrical power requirements will depend on a number of factors, such as the type of AER and the method used to heat water. Some AERs will need a three-phase supply. The manufacturer should provide details of the type of supply, number of phases, frequency and voltage, with tolerances and loading.

3.15 Each AER should be connected via an isolator. The type of isolator will depend on the nature of the supply and its location. For instance, in some locations exposed to a risk of water spray, the ingress protection (IP) rating should be considered.

- For small AERs and bench-top AERs with a maximum current demand not exceeding 13 A on a single-phase supply, isolation may be provided by a switched fused connection unit with a flex outlet. Where several machines are located on the same bench, the connection unit should be labelled to show which machine it is controlling.
- If a three-phase and neutral supply is required or when the maximum demand from a single-phase supply is more than 13 A, the AER should be wired directly to an isolator. The cable from isolator to AER should be fixed and protected from the effects of heat and water.

3.16 Within the loading area, an additional switch should be provided so that the operator can electrically isolate the AER or group of AERs in the event of an emergency. The switch should be placed at a convenient height between the normal operating position and the exit door and labelled "Emergency switch for AERs" to show its function.

3.17 For multiple installations, it may be necessary for the switch to control a contactor, which isolates the distribution board supplying the AERs.

3.18 It is not normally necessary for AERs to be connected to the essential supplies circuit. Exceptions might include the decision to ensure that one AER within the endoscopy unit remains on the essential supplies circuit. Guidance on the supply of electricity in the event of failure of the normal supply is given in WHTM 06-01 – 'Electrical services: supply and distribution'.

### 3.19 Other requirements

- All electrical installations should conform to BS 7671. Further guidance is given in WHTM 06-01 Parts A and B and WHTM 06-02 'Electrical safety guidance for low voltage systems'.
- The artificial lighting installation should conform to CIBSE Lighting Guide02: Hospitals and Health Care Buildings.
- Emergency escape lighting should conform to BS 5266. Consideration should be given to the provision of high risk task lighting area for emergency lighting in the unit/room(s) as part

of the emergency escape lighting provision in accordance with BS 5266.

- Fire alarm provision should be in accordance with WHTM 05-03 Part B 'Fire detection and alarm systems' and BS 5839. Location of devices should be selected and positioned in relation to the risks present in the room whilst avoiding false alarms. Noisy environments may require the provision of audible alarms.

## Drainage

3.20 All effluent from an AER is potentially contaminated and should be disposed of to the main drain.

3.21 Effluent may originate from each of the stages of the process, which may include:

- flushing to remove gross contamination;
- washing with detergent and/or enzymatic cleaners;
- rinsing, with or without the addition of a neutraliser;
- chemical disinfection;
- post-disinfection rinsing;
- drying.

3.22 Effluent from the initial stages, (a) and (b) above, of the process may contain significant concentrations of organic contaminants and potentially infective microorganisms. Effluent from the middle stages, (b), (c) and (d) above, may also contain some organic contaminants and potentially infective microorganisms and high concentrations of process chemicals.

3.23 Effluent from AERs should pass via an air gap into a tundish or tank before being discharged to drain. The air gap should be preserved at all times to prevent the AER and its associated pipework being contaminated by reverse flow from the drainage system.

3.24 When a tank supplies water to a pump on the AER, the overflow discharge from the tank should also include an air gap.

3.25 The drainage system from the installation should be trapped and designed to pass the flow-rate of water, air and condensed steam specified by the manufacturer, with account taken of the peak output during the operating cycle.

3.26 The drainage system should be designed to pass and maintain in suspension the solids removed from the load during the flushing process. The minimum diameter of the drainage system should



be greater than the maximum diameter of the most restricted section of the discharge from the AER chamber.

- 3.27 Means should be provided to prevent, as far as possible, toxic gases being liberated into the atmosphere, particularly into the work area.
- 3.28 If thermal self-disinfection is used, the discharge temperature from an AER may be as high as 85°C. The materials used for the construction of the discharge system should be chosen to withstand temperatures up to 100°C.
- 3.29 The materials used for the construction of the discharge system should be chosen to withstand temperatures up to 100°C. Attention is drawn to the requirement of an organisation to comply with temperature restrictions identified in local water regulations. Historically the temperature of any liquid to be emptied into the public sewer or communicating drain was not to exceed 43°C. This should be interpreted as referring to the main building connection to the sewer and not to the internal building drain. However, if the installation is in a small medical unit, the drains may well connect directly to the main sewers and will therefore be subject to the temperature restriction.
- 3.30 The drain system will need to withstand the action of chemicals used in the AER process. RO water, possibly used in the final rinse stage, may corrode materials.

## Hazardous effluents

- 3.31 The discharge of soil from AERs should be regarded as being no more, but no less, hazardous than the discharge from any other sanitary appliance, for example, a WC.
- 3.32 The discharge of process chemicals, including detergents and disinfectants, may require special attention. The local water company should be consulted before such chemicals are discharged into the drainage system, as it may be necessary to neutralise or inactivate them before discharge.
- 3.33 A sealed and vented drain should be used for the discharge of chemicals with a significant vapour pressure, determined at the maximum attainable temperature of effluent in the drain, which may be hazardous to health or a nuisance. Possible backflow from the drain should be prevented by the inclusion of a check valve and a vacuum breaker. The discharge of toxic gases from the drain system into the work area should be avoided.

## Ventilation

- 3.34 Ventilation of the area near AERs may be needed to remove excessive heat and humidity, and also vapours from disinfectants such as peracetic acid.
- 3.35 Electrical systems used in ventilation installations should take account of the high levels of humidity that may be discharged and the potential for this to condense within the ventilation system.
- 3.36 All ventilation systems should meet the ventilation requirements of the Workplace (Health, Safety and Welfare) Regulations.
- 3.37 The AER, including any special ventilation equipment necessary for its safe operation, will be subject to the COSHH Regulations. These regulations introduced controls on biological agents, which are of relevance to purchasers of AERs.
- 3.38 Detailed guidance on ventilation systems is provided in WHTM 03-01 'Specialised ventilation for healthcare premises'.

### General room ventilation

- 3.39 The ventilation system to an area of endoscope cleaning and AER loading should be at a pressure below atmospheric.
- 3.40 If the endoscope decontamination area is divided into clean and dirty areas or rooms, the ventilation system should be designed accordingly for the dirty wash area and clean processing or storage to the recommendations given in Appendix 2 of WHTM 03-01, Part A. (See also [Table 1](#) in this WHTM).
- 3.41 In designing the ventilation system, several factors are of particular importance:
- the provision of adequate airflow to prevent the build-up of toxic gases given off when the AER lid or door is opened to remove the load;
  - the provision of adequate cooling so that working conditions remain comfortable for staff;
  - correct sizing of the room ventilation system and/or interlocking with extract fans on AERs and other extraction systems in the area to ensure correct operation of both the room ventilation system and the machine/process specific extraction system(s) when extraction fans on AERs and/or local extraction is in operation;
  - the air-flow should be from clean to dirty areas.

## AER ventilation

### *Air quality*

- 3.42 The quality of air may be critical for some applications, and some AERs will incorporate appropriate filters. When the purchaser is to be responsible for the provision of filtered air, the CP(D) should ensure that the quality of air available meets the AER manufacturer's specification or the requirements given below.
- 3.43 Air that could come into direct contact with the load, such as air used for drying the load or testing the free-passage of lumens, should be oil-free (that is, should have no more than 0.5 mg of oil per cubic metre of free air measured at 1013 mbar and 20°C; (see ISO 554), be filtered to an efficiency of at least 95% when tested in accordance with BS 3928 and be free of bacteria (see WHTM 02-01 'Medical gas pipeline systems').
- 3.44 Air for control purposes should be free of liquid water, filtered to 25 µm (5 µm for precision controls) and lubricated with micro-fog oil particles of 2 µm or less.

### *Air pressure*

- 3.45 AERs may run under a slight negative pressure in the chamber to minimise the potential for the discharge of chemical vapours into the environment.

### *Air extraction system*

- 3.46 AERs not equipped with an air extraction system may require an extraction device to be mounted above the door or lid to reduce chemical vapours entering the workspace.
- 3.47 The air extracted from AERs operating a heated self-disinfection stage will normally have a high moisture level during this stage. The extraction system should, therefore, be equipped with a drain to discharge the condensate and should be designed and constructed so that it may be cleaned periodically. The drainage system should be constructed with a continuous fall to discharge, without any upstand at the point of connection to the ventilation system to prevent pooling.
- 3.48 The output from an extraction system may contain chemical vapours and should be discharged away from opened windows, air intake systems, general ventilation extraction systems or where down-draughts occur. It is important that adequate dispersal is achieved and roof-level discharge is preferred. The extract from two or more AERs should not use common ducting unless provision is made to ensure that there is no risk of cross-connection. AER manufacturers

should provide advice on the COSHH implications of any system upgrade or new installation in alignment with localised ventilation systems installed.

- 3.49 The extraction ductwork connected to the AER is an efficient transmission system for noise originating within either the AER or extraction plant. Care is needed in the design and construction of the ducting to ensure that noise does not become a problem. This may require the use of sound attenuators as part of the ductwork design. Additional guidance is given in Part A of WHTM 03-01 and WHBN 13.

## Chemical additives

- 3.50 Safe storage provision is needed for containers of chemical additives used in the AER (see 'Safety of AER chemicals' in WHTM 01-06 Part C 'Operational management').

## Infectious materials

- 3.51 All AERs have the potential to process infectious materials. The User should therefore ensure that personnel working on AERs wear appropriate protective clothing and are fully informed of any hazards that may be present. In case of doubt, the microbiologist should be consulted. External maintenance and test engineers should obtain a permit-to-work before entering the endoscopy unit.
- 3.52 Any test equipment and tools used on an AER should be regarded as potentially infectious. Therefore such items should be handled with care and be disinfected after use, unless they have been processed by a complete AER cycle.

## Engineering services checklist

- 3.53 Check that the following requirements have been met:
1. The engineering services have been installed correctly; they are adequate to meet the demands of the AER; they do not leak and all necessary isolating valves/switches and test points have been installed.
  2. Drains remove effluent effectively when all plant in the vicinity, including the AER, is connected and operating.
  3. The water treatment plant, if fitted, operates correctly and the quality of water supplied for each stage of the process is in accordance with the specification.
  4. The provision for storage, handling and connection to the AER for all process

chemicals meets the requirements for safe handling of potentially hazardous chemicals.

5. The exhaust ventilation unit fitted to the AER is adequate to remove the air evolved from the washing, disinfection, drying and unloading processes.
6. AERs employing chemicals that are volatile require exhaust ventilation to maintain the environmental concentration below any limit specified for occupational exposure and to ensure that the discharge is to a safe place.
7. Subject to local policy related to throughput, it is recommended that data connection points (ethernet) be provided at carefully considered locations to permit the capture of information for appropriate device tracking (see 'Tracking, traceability and audit trail' in WHTM 01-06 Part C).

# References

## Acts and Regulations

*The acts and regulations shown below can be accessed from the [www.legislation.gov.uk/](http://www.legislation.gov.uk/) website*

Carriage of Dangerous Goods and Transportable Pressure Equipment Regulations

Control of Substances Hazardous to Health Regulations (COSHH)

Medical Devices Regulations

Water Supply (Water Fittings) Regulations

Workplace (Health, Safety and Welfare) Regulations

## British Standards Institution

<http://shop.bsigroup.com/en/>

**BS 5266** Emergency lighting

**BS 5839-1** Fire detection and fire alarm systems for buildings

**BS 6920-2.4** Suitability of non-metallic products for use in contact with water intended for human consumption with regard to their effect on the quality of water  
Methods of test

**BS 7671** Requirements for electrical installations. IET Wiring Regulations.

**BS 1752:1983, ISO 4793:** 1980 Specification for laboratory sintered or fritted filters including porosity grading

**BS EN ISO 13485** - Medical devices. Quality management systems. Requirements for regulatory purposes

**BS EN ISO 15883-1** Washer-disinfectors. General requirements, terms and definitions and tests

**BS EN ISO 15883-4** Washer-disinfectors. Requirements and tests for washer-disinfectors employing chemical disinfection for thermolabile endoscopes

**BS EN 1717** Protection against pollution of potable water in water installations and general requirements of devices to prevent pollution by backflow

## CIBSE

<http://www.cibseknowledge>

Lighting Guide 02: Hospitals and Health Care buildings

## Health & Safety Executive (HSE)

[www.hse.gov.uk/](http://www.hse.gov.uk/)

Legionnaires' disease. The control of legionella bacteria in water systems. Approved Code of Practice and guidance (L8)

<http://www.hse.gov.uk/pubns/books/l8.htm>

Legionnaires' disease. Technical guidance HSG274  
<http://www.hse.gov.uk/pubns/books/hsg274.htm>

## International Organization for Standardization (ISO)

<http://www.iso.org/iso/home/about.htm>

ISO 554:1976 Standard atmospheres for conditioning and/or testing -- Specifications

## NHS Wales Shared Services Partnership - Facilities Services

The publications below are available from the NHS Wales Shared Services Partnership - Facilities Services websites

Intranet: [howis.wales.nhs.uk/whe](http://howis.wales.nhs.uk/whe)

Internet: [www.wales.nhs.uk/whe](http://www.wales.nhs.uk/whe)

*Welsh Health Building Notes (WHBN)*

WHBN 00-09 – Infection control in the built environment

WHBN 00-10 Part A -Flooring

WHBN 00-10 Part B - Walls and ceilings

WHBN 00-10 Part C - Sanitary assemblies

WHBN 13 – Sterile service department

*Welsh Health Technical Memorandum (WHTM)*

WHTM 01-06 Decontamination of flexible endoscopes, Part A: Policy and management

WHTM 01-06 Decontamination of flexible endoscopes, Part C: Operational management

WHTM 01-06 Decontamination of flexible endoscopes, Part D: Testing methods

WHTM 01-06 Decontamination of flexible endoscopes, Part E: Validation and verification

WHTM 02-01 –Medical gas pipeline systems Part A: Design, installation, validation and verification

WHTM 02-01 – Medical gas pipeline systems Part B: Operational management

WHTM 03-01 – Specialised ventilation for healthcare premises Part A: Design and validation

WHTM 03-01 – Specialised ventilation for healthcare premises Part B: Operation management performance verification

WHTM 04-01 - The control of Legionella, hygiene, 'safe' hot water, cold water and drinking water systems, Part A: Design, installation and testing

WHTM 04-01 - The control of Legionella, hygiene, 'safe' hot water, cold water and drinking water systems, Part B: Operational management

WHTM 05 – Firecode suite

WHTM 05-03: Part B – Fire detection and alarm systems

WHTM 06-01 – Electrical services supply and distribution Part A

WHTM 06-01 – Electrical services supply and distribution Part B

WHTM 06-02 – Electrical safety guidance for low voltage systems

## Welsh Government

[www.wales.gov.uk](http://www.wales.gov.uk)

### *Building Regulations Approved Documents*

<http://wales.gov.uk/topics/planning/buildingregs/publications/?lang=en>

Approved Document B – Fire safety

<http://wales.gov.uk/topics/planning/buildingregs/publications/part-b-fire/?lang=en>

### *Chief Medical Officer*

<http://wales.gov.uk/topics/health/cmo/?lang=en>

CMO (2010)04 Decontamination of medical devices – automated endoscopy reprocessors and potable water  
[howis.wales.nhs.uk/sites3/Documents/254/CMO%202010%2004.pdf](http://howis.wales.nhs.uk/sites3/Documents/254/CMO%202010%2004.pdf) (*Facilities Services Intranet only*)

CMO(2010)13 Water sources and potential for cross infection from taps and sinks

## World Health Organisation

[http://www.who.int/water\\_sanitation\\_health/dwq/guidelines/en/](http://www.who.int/water_sanitation_health/dwq/guidelines/en/)

Guidelines for drinking water quality