

# HEALTH TECHNICAL MEMORANDUM 08-01

## Acoustics

2011

***STATUS IN WALES***

***APPLIES***

This document has been created from the  
Space for Health website content manual

It will eventually be superseded by a new  
Welsh Health Technical Memorandum



Partneriaeth  
Cydwasaethau  
Gwasanaethau Cyfleusterau  
Shared Services  
Partnership  
Facilities Services

For queries on the status of this document contact  
[info@whe.wales.nhs.uk](mailto:info@whe.wales.nhs.uk) or telephone 029 2031 5512

Status Note amended March 2013



GIG  
CYMRU  
NHS  
WALES

Partneriaeth  
Cydwasaethau  
Gwasanaethau Cyfleusterau

Shared Services  
Partnership  
Facilities Services

# Acoustics: Technical design manual

## Version:0.3:Wales





# Contents

		<i>page</i>
<b>Overview</b>	<b>100 v1.2</b>	<b>p5</b>
<b>Introduction</b>	<b>4034 v1.2</b>	<b>p6</b>
<b>Acoustic criteria</b>	<b>4035 v1.2</b>	<b>p7</b>
Internal noise levels from external sources	4046 v1.2	p8
Pre-design noise survey	4047 v1.2	p8
Noise intrusion	4048 v1.2	p8
Sporadic events	4049 v1.2	p10
Rain noise	4050 v1.2	p10
Internal noise from mechanical and electrical services		
	4051 v1.2	p12
Normal operating conditions	4052 v1.2	p12
Medical equipment	4053 v1.2	p13
Emergency plant	4054 v1.2	p13
Materials	4055 v1.2	p14
Pneumatic tube systems	4056 v1.2	p14
Nurse-call systems	4057 v1.2	p14
Plantrooms	4058 v1.2	p14
Services and sound insulation	4059 v1.2	p15
External noise levels	4062 v1.2	p16
Internal sound insulation	4066 v1.2	p17
Long-term accommodation	4068 v1.2	p23
Doors	4069 v1.2	p24
Examples of design conflicts to be considered		
	4070 v1.2	p25
Openable windows	4071 v1.2	p27
Movable/folding partitions	4072 v1.2	p29
Structure-borne sound and lightweight constructions		
	4073 v1.2	p30
Controlling background sound	4074 v1.2	p31
Sound-flanking paths	4075 v1.2	p32
Height of partitions	4076 v1.2	p37
Bathroom pods	4077 v1.2	p38
Impact sound insulation	4078 v1.2	p39

Room acoustics	4079 v1.2	p40
Audio systems for public announcements	4080 v1.2	p42
Audiology facilities	4081 v1.2	p43
Vibration	4082 v1.2	p44
Continuous vibration	4083 v1.2	p45
Intermittent vibration	4084 v1.2	p45
Vibration-sensitive equipment	4085 v1.2	p46
<b>Construction noise and vibration</b>	<b>4036 v1.2</b>	<b>p47</b>
<b>Temporary healthcare facilities</b>	<b>4037 v1.2</b>	<b>p48</b>
<b>Refurbished accommodation</b>	<b>4038 v1.2</b>	<b>p49</b>
<b>Inspecting works during construction</b>	<b>4039 v1.2</b>	<b>p50</b>
<b>Testing and validation</b>	<b>4040 v1.2</b>	<b>p51</b>
Sound insulation	4100 v1.2	p52
Noise levels generated by mechanical and electrical services	4121 v1.2	p53
Intrusive noise	4123 v1.2	p54
Audio system intelligibility	4125 v1.2	p55
Environmental noise	4127 v1.2	p56
Audiometric testing rooms	4181 v1.2	p57
General comments	4184 v1.2	p58
Failure to meet criteria	4186 v1.2	p59
Commissioning results	4189 v1.2	p60
<b>Checklists</b>	<b>4041 v1.2</b>	<b>p61</b>
<b>Partition and floor sound insulation</b>	<b>4042 v1.2</b>	<b>p63</b>
Example 1. Lightweight partition – absorbent ceilings	4213 v1.2	p66
Example 2. Concrete floor – absorbent ceilings	4219 v1.2	p67
Example 3. Lightweight partition – non-absorbent ceilings	4222 v1.2	p68
Example 4. Lightweight partition – absorbent ceilings – different room uses	4223 v1.2	p69
Example 5. Lightweight partition – absorbent ceilings – small non-sensitive room	4225 v1.2	p71
<b>Calculation of equivalent absorption area</b>	<b>4043 v1.2</b>	<b>p73</b>
Method A	4228 v1.2	p73
Method B	4229 v1.2	p73
<b>Worked examples of vibration performance criteria</b>	<b>4044 v1.2</b>	<b>p75</b>
<b>Glossary</b>	<b>4298 v1.2</b>	<b>p77</b>

# Overview

100

7619

7715

This manual has been written for healthcare professionals to understand acoustic requirements and to help those involved in the development of healthcare facilities.

It sets out acoustic criteria for the design and management of new healthcare facilities. The manual does not give solutions to meet the acoustic criteria; designers on each individual project should develop these.

A specialist acoustic adviser should be used to take a holistic approach to the acoustic design. Therefore detailed acoustic theory is not included in this manual, although sufficient detail is given for a basic understanding of the acoustic issues. It would be unwise to design a healthcare development without specialist acoustic advice right from the outline design stage.

Acoustic design is fundamental to the quality of healthcare buildings. Sound affects us both physiologically and psychologically. Noise, which can be defined as “unwanted sound”, can increase heart rate, blood pressure, respiration rate and even blood cholesterol levels. Pleasant sounds help create a sense of well-being. Music can be used to treat depression, to reach autistic people and to calm and relax tense patients.

Good acoustic conditions improve patient privacy and dignity, and promote essential sleep patterns. Such conditions are key to healing. Good acoustic design brings other benefits in terms of patient and staff comfort and morale, as well as improved efficiency and usability of equipment.

# Introduction

4034

4033

This manual covers the acoustic design criteria that are important for healthcare premises, and addresses issues such as the provision of temporary healthcare facilities, refurbishments and the control of noise and vibration during construction.

Testing during and after construction, which is essential for quality assurance, is explained. Checklists are included of the most important acoustic issues that need to be considered in the design of any healthcare facility.

Examples are also included, at the end of the guidance, of some of the required calculations.

The document recommends acoustic criteria for:

- \* noise levels in rooms – both from mechanical services within the building and from noise coming from outside. It is important to create an acoustic environment that allows rooms to be used for resting, sleeping, treatment, consultation and concentration. There are also statutory limits for noise levels that individuals can be exposed to whilst working;
- \* external noise levels – noise created by the healthcare building and operation should not unduly affect those that live and work around it;
- \* sound insulation between rooms – allows rooms to exist side by side. Noisy activities should not interfere with the requirements of adjacent rooms, and private conversations should not be overheard outside the room. The guidance given now allows for raised voices being commonly expected for hearing-impaired patients and staff;
- \* impact sound insulation – prevents footfall noise of people walking over rooms interfering with the use of rooms below;
- \* room acoustics – guidance is given on quantities of acoustically-absorbent material to provide a comfortable acoustic environment;
- \* audio systems – announcements to patients, visitors and staff should be intelligible;
- \* audiology facilities – without proper acoustic conditions the hearing-test facilities cannot function;
- \* vibration caused by plant, medical equipment and activities should not affect the use of the building. Some medical equipment is sensitive to vibration, and so are people.

# Acoustic criteria

4035

4240

It is important to set appropriate acoustic design criteria for healthcare premises. This manual sets out the minimum recommended criteria. Each development has special features, and these criteria may not be appropriate for all projects.

A statement of acoustic criteria should be prepared for each project. This will set out the acoustic requirements and the particular acoustic issues that affect the development. The presumption will be that these criteria will equate to those listed in this manual. The onus will be on designers to identify whether the acoustic criteria given can be achieved and to set out an argument for changing them.

The parameters to be considered include:

- \* equivalent continuous sound pressure level ( $L_{Aeq}$ );
- \* noise rating (NR) curves;
- \* vibration dose value (VDV);
- \* weighted standardised level difference ( $D_{nT,w}$ );
- \* weighted standardised impact sound pressure level ( $L'_{nT,w}$ );
- \* room acoustics; and
- \* speech transmission index (STI).

Noise criteria for mechanical services should be specified in terms of an NR value for each area under consideration. Appropriate values are quoted for various locations.

Sound insulation of external façades depends on external noise levels and how quiet the rooms inside need to be. Appropriate noise levels in rooms are recommended.

Sound insulation of internal partitions is linked to the degree of privacy that is necessary, and the need to reduce noise from other rooms. The increasing implications of the loss of privacy on the NHS have also been considered. Therefore acoustic requirements are included to allow for the raised speech that a hearing-impaired person could experience. It is, however, impractical to design internal sound insulation to achieve full speech privacy if shouts and screams occur.

## Internal noise levels from external sources

4046

### Pre-design noise survey

4047

The design should include decisions on the layout of the site to optimise acoustic performance.

Usually, noise should be measured at site before starting the design. Ambient noise levels will be needed in the design process. Vibration measurements may also be needed (for example where the site is near a railway line or when there is equipment sensitive to vibration).

As a minimum, the survey should cover highest daytime noise (and vibration) levels. As the facilities and associated plant usually operate at night, the night-time lowest noise levels will also need to be measured.

A Competent Person (see 'Glossary') should carry out the noise measurements at appropriate locations and times.

The design should be based upon noise levels that take account of anticipated changes on and around the site. For example, if the site will attract more road traffic, the increase in noise level should be predicted and added to measured levels. Changes in road traffic caused by other factors (such as natural growth in road traffic, other new developments etc) should also be included as far as reasonably practicable.

Noise produced by any buildings that are to be retained, and the effect of the new development on them, should be evaluated.

The noise levels on site may dictate ventilation strategy, space planning, building shape and layout.

### Glossary

### Noise intrusion

4048

Table 1 sets out recommended criteria for noise intrusion for the completed building (including normal furniture).

Room type	Example	Criteria for noise intrusion to be met inside the spaces from external sources (dB)
Ward – single person	Single-bed ward, single-bed recovery areas and on-call room, relatives' overnight stay	40 $L_{Aeq, 1hr}$ daytime 35 $L_{Aeq, 1hr}$ night 45 $L_{Amax, f}$ night
Ward – multi-bed	Multi-bed wards, recovery areas	45 $L_{Aeq, 1hr}$ daytime 35 $L_{Aeq, 1hr}$ night 45 $L_{Amax, f}$ night
Small office-type spaces	Private offices, small treatment rooms, interview rooms, consulting rooms	40 $L_{Aeq, 1hr}$
Open clinical areas	A&E	45 $L_{Aeq, 1hr}$
Circulation spaces	Corridors, hospital street, atria	55 $L_{Aeq, 1hr}$
Public areas	Dining areas, waiting areas, playrooms	50 $L_{Aeq, 1hr}$
Personal hygiene (en-suite)	Toilets, showers	45 $L_{Aeq, 1hr}$
Personal hygiene (public and staff)	Toilets, showers	55 $L_{Aeq, 1hr}$
Small food-preparation areas	Ward kitchens	50 $L_{Aeq, 1hr}$
Large food-preparation areas	Main kitchens	55 $L_{Aeq, 1hr}$
Large meeting rooms (>35 m <sup>2</sup> floor area)	Lecture theatres, meeting rooms, board rooms, seminar rooms, classrooms	35 $L_{Aeq, 1hr}$
Small meeting rooms (≤35 m <sup>2</sup> floor area)	Meeting rooms, seminar rooms, classrooms, board rooms	40 $L_{Aeq, 1hr}$
Operating theatres	Operating theatres	40 $L_{Aeq, 1hr}$ 50 $L_{Amax, f}$
Laboratories	Laboratories	45 $L_{Aeq, 1hr}$

Table 1 Criteria for noise intrusion from external sources

**Notes:**

Night is defined as the hours between 23.00 and 07.00.

A  $L_{Amax, f}$  limit for short-term events is included for sleeping areas and operating theatres. The intention is that this should apply to events that occur several times during the night (for example passing trains) rather than sporadic events (see 'Sporadic events' below).

Where windows have trickle vents, the criteria would normally apply with the windows closed but trickle vents open. If natural ventilation is provided by means other than trickle vents, the acoustic criteria are to be achieved while the required amount of ventilation is supplied.

To achieve the acoustic criteria on noisy sites, acoustically treated trickle vents or mechanical ventilation may be required. Sealed façades may be necessary for the

noisiest sites. The acoustic adviser should liaise with the services designer to establish what constitutes the required amount of ventilation, the size of trickle vents, and the acoustic implications of natural ventilation.

Noise from a service yard and other similar activities should be designed not to disturb noise-sensitive accommodation or noise-sensitive receptors outside the site. Where possible, the service yard should be kept away from accommodation, and canopies and other acoustic screening methods should be considered. Without these, it is unlikely that noise-sensitive rooms overlooking a service yard can use trickle vents or openable windows for ventilation. A sealed façade and mechanical ventilation are therefore likely to be required in these locations.

The intrusive noise criteria do not include plant noise from adjacent hospital buildings. This should be considered as mechanical service noise (see 'Internal noise from mechanical and electrical services').

### Internal noise from mechanical and electrical services

## Sporadic events

4049

Hospitals are often affected by noisy but sporadic events such as vehicle sirens, helicopters and aircraft. Each source has to be considered separately and an appropriate strategy devised.

A policy of no sirens on site (unless essential) is recommended.

It is unlikely that the criteria in Table 1 will be achievable with helicopter movements included, so helicopters may cause some disturbance. Careful planning of the hospital layout and flight path can, however, reduce the effects of helicopter noise.

## Rain noise

4050

Rain noise should not result in undue disturbance in internal spaces. Some noise from rain is acceptable in most types of room, and indeed can be comforting to occupants.

Indoor ambient-noise levels during “heavy” rainfall should not exceed the intrusive noise criteria in Table 1 by more than 20 dB(A) or should not be more than 65 dB(A), whichever is lower. “Moderate” and “heavy” rainfall is as described in BS EN ISO 140-18

Suitable lightweight roof constructions that provide sufficient attenuation will probably consist of many layers.

Laboratory-measured data is needed to assess the noise level that will result inside the building. Calculations of the expected noise level based on the laboratory test data will normally be sufficient to prove the performance.

Ideally, noise from rainwater pipes within the building needs to meet the service-noise criteria given in Table 2 (see 'Internal noise from mechanical and electrical services') under “moderate” rainfall conditions [“moderate” and “heavy” rainfall is as described in BS EN ISO 140-18]. Some acoustic treatment to internal pipework may be required.

#### Internal noise from mechanical and electrical services

## Internal noise from mechanical and electrical services

4051

### Normal operating conditions

4052

The criteria in Table 2 refer to the total noise from mechanical and electrical services (including rainwater pipes draining under “moderate” rainfall conditions, noise from plantrooms and from plant areas in other parts of the building or site), excluding medical equipment. The noise rating (NR) should take account of the noise in the octave band range from 63 Hz to 4 kHz.

The limits are defined in terms of  $L_{90}$  and are to be achieved in the completed building (including normal furniture). For design purposes, it can be assumed that the  $L_{eq}$  of plant noise is the same value as the  $L_{90}$  for continuously operating plant. Noise generated by services should be steady, with no periodic change in noise level or character.

Continuous sound generated by services can provide useful masking noise for public areas. It is therefore not advisable to over-attenuate service-noise in these areas.

Area type	Example	Noise from mechanical and electrical services
Ward areas, sleeping areas	Single-bed ward, multi-bed ward, on-call rooms, relatives' overnight stay Recovery rooms	NR 30
		NR 35
Small office-type spaces	Private offices, treatment rooms, interview rooms, consulting rooms	NR 35
Open clinical areas	A&E	NR 40
Circulation spaces	Corridors, hospital street, atria	NR 40
Public areas	Waiting areas, dining, playroom	NR 40
Personal hygiene (en-suite)	Toilets, showers	NR 40
Personal hygiene (general access)	Toilets, showers	NR 45
Small food-preparation areas	Ward kitchens	NR 40
Large food-preparation areas	Main kitchens	NR 50 (NR 55 below extract hoods)
Large meeting rooms (>35 m <sup>2</sup> floor area)	Lecture theatres, meeting rooms, seminar rooms, board rooms, classrooms	NR 30
Small meeting rooms (≤35 m <sup>2</sup> floor area)	Meeting rooms, seminar rooms, board rooms, classrooms	NR 35
Operating theatres (excluding laminar-flow theatres)	Operating theatres	NR 40
Laminar-flow theatres	Ultra-clean theatre	NR 50
Laboratories		NR 40 when laboratory has no fume cupboards NR 60 at 1 m from fume cupboards with open sash
Utility rooms	Clean utility, dirty utility	NR 40

**Table 2 Criteria for internal noise from mechanical and electrical services**

## Medical equipment

4053

The criteria in Table 2 do not include values for medical equipment. Such equipment is usually procured and installed separately to the other services. The noise from medical equipment should be considered when it is selected. Ideally, it should be chosen so that it does not adversely affect the use of its surrounding space.

Quiet equipment should be chosen.

In sleeping areas, intermittent noise or increased background noise levels can disturb sleep. In other areas (for example X-ray rooms), small increases in noise caused by medical equipment may be acceptable.

Whether any increase above the background levels in Table 2 is acceptable can only be established on a case-by-case basis.

## Emergency plant

4054

An increase in internal and external noise levels of up to 10 dB(A) over the noise criteria is normally considered acceptable, provided regular testing only takes place during the daytime on a weekday.

Audible alarms need to be sufficiently noisy to attract the attention of the relevant people.

## **Materials** 4055

Where clinically necessary, acoustic treatments to control noise generated by mechanical and electrical services should incorporate bagged and sealed acoustic media.

## **Pneumatic tube systems** 4056

Noise breakout from pneumatic tube transport systems should be assessed, and pipes routed carefully to avoid sensitive spaces. Some acoustic treatments may be required.

## **Nurse-call systems** 4057

Nurse-call systems can disrupt sleep; therefore non-audible systems should be considered, especially at night. The most appropriate systems should be selected for each project.

Audible alarms intended for staff should be located such that they cause minimum disruption to patients (see 'Bedhead services' for further guidance on nurse-call systems).

[Bedhead services: Technical design manual](#)

## **Plantrooms** 4058

Noise levels in plantrooms should allow normal maintenance without the need for ear protection. This means that selection of quiet versions of plant and/or noise control packages (including enclosures) should be given high priority. The Control of Noise at Work Regulations 2005 require noise levels to be reduced as far as reasonably practicable.

If it is not reasonably practicable to reduce noise levels below the limits where hearing protection is required (for example generator plantrooms), appropriate warning signs, training, procedures to enforce the wearing of hearing protection etc must be provided as indicated in the current legislation.

Reducing noise in plantrooms also benefits by reducing the sound-insulation requirements of the building structure.

Major items of plant, such as generators, chillers, boilers, and combined heat and power (CHP) systems (which may all be in an energy centre), should be as remote as possible from the hospital accommodation. Otherwise significant noise control will be needed on noisy plant. Note, however, that the need for noise control may be driven by environmental noise limits (see 'External noise levels').

[External noise levels](#)  
[Control of Noise at Work Regulations 2005](#)

## Services and sound insulation

4059

The installation of services can dramatically affect sound insulation. Air-transfer grilles are a major cause of acoustic weakness, as are poorly sealed penetrations, common ducts etc. Architects, service engineers and acoustic designers should ensure that the layout of services is appropriate and that their installation does not downgrade acoustic performance.

Crosstalk attenuation is likely to be required in ducted ventilation systems that link rooms requiring sound insulation. The sound-insulation criteria between rooms (see Table 5 under 'Sound insulation for rooms') should apply to noise transfer via all routes – including ducts.

Sockets, switches, medical-gas outlets, integrated plumbing system (IPS) panels etc should not be back-to-back in partitions intended to provide sound insulation.

High-performance partitions may also need to incorporate acoustic backing boxes on sockets. Stood-off IPS panels and surface-fixed sockets and switches are preferable from an acoustic perspective.

WC cisterns and wastes, hand-wash basin waste etc should not be mounted within the cavity of lightweight partitions where the partition separates a bathroom from a “medium” or “sensitive” noise-sensitivity room (see Table 3 under 'Sound insulation for rooms'), except for an en-suite serving its own single bedroom.

Bathroom pods need to incorporate sufficient sound insulation to meet the criteria in 'Internal sound insulation'. If they are to be installed back-to-back, it is preferable to install imperforate, acoustically-rated partitions between pods. This might affect construction sequences and space planning. Otherwise this means considering the envelope of the pod, especially the roof, where there are often penetrations. Access to the roof to install sound-insulating material is difficult on site.

Where a bathroom pod is a part of a single bedroom, it should be considered an integral part of the bedroom and should provide the same sound insulation to other rooms as a single bedroom (see 'Sound insulation for rooms').

### Sound insulation for rooms

## External noise levels

4062

4117

Noise from healthcare premises can affect properties outside the site. This should be considered when stipulating environmental noise criteria for the project. These external criteria should be agreed with the local authority and should include any differences allowed for emergency equipment.

The following provisions should apply, with the most stringent taking precedence:

- \* Noise levels at the site boundary should meet reasonable standards required by the local authority or other relevant body.
- \* Noise outside the buildings should be controlled to allow the internal noise criteria to be achieved (with windows or trickle vents open for ventilation if the space is naturally ventilated).
- \* Open external areas should be protected. Noise from services should not exceed the existing daytime background noise level or 50 dB  $L_{A90}$ , whichever is the higher. This limit should be achieved in any areas normally occupied by staff (except maintenance staff, notwithstanding the requirements of the Control of Noise at Work Regulations 2005) or the public (for example open courtyards and accessible landscape areas). This means that noisy plantrooms should not face normally occupied external areas unless adequate acoustic control is provided.

A relaxation of acoustic criteria for emergency situations and sporadic events (for example standby generators and helicopter flights) can be considered. This is subject to agreement by the local authority or other relevant body.

**Control of Noise at Work Regulations 2005**

## Internal sound insulation

4066

4116

Appropriate sound insulation needs to be set for each room. Noisy activities should not interfere with the need for quiet in adjacent rooms.

Private conversations should not be overheard. The right to privacy for hearing-impaired patients and staff has been taken into account.

This manual therefore takes into account the noise from raised voices, which is commonly expected in a healthcare environment.

Acoustic requirements for partitions and floors are set out in Tables 3 and 4. Table 3 gives the privacy of a source room, anticipated levels of noise generation and the sensitivity of the spaces. For “partition” also read “floor”.

Room	Privacy requirements for source room	Noise generation of the source room	Noise sensitivity of receiving room
<b>Clinical areas</b>			
Single-bed/on-call room	Confidential	Typical	Medium
Multi-bed room	Moderate	Typical	Medium
Children & older people (single bed)	Private	High	Medium
Children & older people (multi-bed)	Moderate	High	Medium
Consulting room	Confidential	Typical	Medium
Examination room	Confidential	Typical	Medium
Treatment room	Confidential	Typical	Medium
Counselling/bereavement room	Confidential	High	Medium
Interview room	Confidential	Typical	Medium
Operating theatre suite	Private	Typical	Sensitive
Nurseries	Moderate	Very high	Medium
Birthing room	Private	Very high	Medium
Laboratories	Moderate	Typical	Medium
Dirty utility/sluite	Not Private	High	Not sensitive
Clean utility	Not Private	Low	Not sensitive
Speech and language therapy	Confidential	High	Sensitive
Snoezelen/multi-sensory room	Confidential	High	Sensitive
<b>Public areas</b>			
Multi-faith/chapel	Private	High	Sensitive
Corridor (no door)	Not private	Typical	Not sensitive
Atrium	Not private	High	Not sensitive
Dining	Not private	High	Not sensitive
Toilets (not cubicles)	Moderate	Typical	Not sensitive
Waiting (large >20 people)	Not private	High	Not sensitive
Waiting (small ≤20 people)	Not private	Typical	Not sensitive
<b>Staff areas</b>			
Toilets (not cubicles)	Moderate	Typical	Not sensitive
Main kitchen	Not private	Very high	Not sensitive
Ward kitchen, pantry	Not private	Typical	Not Sensitive
Storeroom	Not private	Low	Not sensitive
Rest room	Moderate	High	Medium
Locker/changing room	Moderate	Typical	Not sensitive
Large training/seminar (>35 m <sup>2</sup> )	Private	High	Medium
Small training/seminar (≤35 m <sup>2</sup> )	Private	Typical	Medium
Lecture theatre	Private	High	Sensitive
Library/archiving room	Moderate	Low	Sensitive
Single-person office	Private	Typical	Medium
Multi-person office (2–4 people)	Moderate	Typical	Medium
Open-plan office (≥5 people)	Not private	Typical	Medium
Boardroom	Confidential	High	Medium
Large meeting room (>35 m <sup>2</sup> )	Private	High	Medium
Small meeting room (≤35 m <sup>2</sup> )	Private	Typical	Medium

Table 3 Sound-insulation parameters of rooms

Table 4 is then used to select the standard of sound insulation required based on these parameters in terms of the weighted standardised level difference ( $D_{nT,w}$ ). This parameter is measured on site.

The sound-insulation requirement is assessed between a pair of rooms in each direction (room A to room B and room B to room A) using the privacy requirement for the source room, the noise generation of the source room and the noise sensitivity of the receiving room (see Table 4). Examples of how to calculate this are given in 'Partition and floor sound insulation'.

Manufacturers of building materials provide data for their products in terms of the weighted sound reduction index ( $R_w$ ), which is measured in a laboratory. The required partition  $R_w$  needs to be calculated (using the equations below) in each direction and the higher  $R_w$  rating used for selecting the partition from manufacturers' data. The  $R_w$  is normally higher than the on-site  $D_{nT,w}$  figure, and this difference can be significant.

If a specific room type is not listed, the sound insulation requirements can be derived. The performance required will depend on the privacy requirement and level of noise generation in the source room, and the sensitivity of the receiving room.

The criteria in Table 4 are for the overall installed performance in terms of  $D_{nT,w}$ , taking account of all sound-transfer paths. To achieve these standards, partitions need a laboratory performance ( $R_w$ ) significantly higher than the site performance stipulated in the table (see 'Partition and floor sound insulation'). Construction details and quality of workmanship are vitally important to achieve an on-site sound-insulation performance. Sound-flanking up, over and around partitions and floors (including penetrations) should not prevent the requirements being achieved (see 'Sound-flanking paths').

For lightweight partitions and floors,  $R_w$  should normally be at least 5 dB higher than  $D_{nT,w}$ , even if flanking is very well-controlled. It is recommended that the difference between  $R_w$  and  $D_{nT,w}$  is assumed to be at least 7 dB, to allow for many common construction/services details. The equations below assume this 7 dB difference.

For masonry walls and concrete floors, the difference between  $R_w$  and  $D_{nT,w}$  is more likely to be 4 dB, providing gaps between blocks are fully filled.

An additional allowance should also be made for the room dimensions and the area of the separating wall/floor.

a. To calculate the  $R_w$  required to meet a given  $D_{nT,w}$  the following relationships should be used:

(i) For lightweight walls/floors:

$$R_w D_{nT,w} + 10 \log (S/V) + 14.$$

(ii) For masonry walls/floors:

$$R_w D_{nT,w} + 10 \log (S/V) + 11.$$

Where:

$S$  = common area of separating element being considered ( $m^2$ ).

$V$  = volume of receiving room ( $m^3$ ).

b. For cuboid-shaped receiving rooms, where the separating element is the whole of one surface, this can be simplified to:

(i) For lightweight walls/floors:

$$R_w D_{nT,w} - 10 \log d + 14.$$

(ii) For masonry walls/floors:

$$R_w D_{nT,w} - 10 \log d + 11.$$

Where:

$d$  = dimension of receiving room perpendicular to separating element being considered (height of room for floor, width or depth of room for partitions, depending on which is perpendicular to the partition being considered).

### Note

means “is equivalent to”.

The figures given in Table 3 and Table 4 are for typical room types. Special constructions to control flanking sound are likely to be required if a performance of  $D_{nT,w}$  52 dB and above is required. Layout planning should therefore avoid adjacencies where  $D_{nT,w}$  52 dB and above is needed.

If a receiving room does not have the minimum absorption area as per 'Room acoustics', 3 dB should be added to the values in Table 4 and Table 5.

Privacy requirement for source room	Noise generation of the source room	Noise sensitivity of receiving room		
		Not sensitive	Medium sensitivity	Sensitive
<b>Confidential</b>	Very high	47	52	52
	High	47	47	52
	Typical	47	47	47
	Low	42	42	47
<b>Private</b>	Very high	47	52	52
	High	42	47	52
	Typical	42	42	47
	Low	37	42	42
<b>Moderate</b>	Very high	47	52	52
	High	37	42	47
	Typical	37	37	42
	Low	No rating	No rating	37
<b>Not private</b>	Very high	47	52	52
	High	No rating	42	47
	Typical	No rating	No rating	42
	Low	No rating	No rating	37

Table 4 Sound-insulation ratings (dB DnT,w) to be achieved on site

**Notes:**

\* = These adjacencies should be avoided by layout planning. Where this is not possible,  $D_{nT,w}$  57 dB needs to be achieved as a minimum. In practice this is extremely difficult, as it would need very wide partitions and place onerous demands on the building structure to control flanking noise sufficiently.

Note that for:

**Confidential** – raised speech would be audible but not intelligible, and normal speech would be inaudible.

**Private** – normal speech would be audible but not intelligible.

**Moderate** – normal speech would be audible and intelligible but not intrusive.

**Not private** – normal speech would be clearly audible and intelligible.

**Sensitive** – room cannot accommodate any noticeable noise from rooms next door.

**Medium sensitivity** – room generally needs to be free from noise of other rooms.

**Not sensitive** – noise from other rooms does not affect the use of the receiving room.

Raised voices are to be reasonably expected in rooms where medical consultation takes place.

For everyone to retain adequate privacy (including those with hearing impairment), bedrooms, consulting rooms, examination rooms and treatment rooms have been

classed “confidential”. Raised speech would be audible but not intelligible in adjacent rooms.

A door in a partition will significantly downgrade the partition’s performance. There is no benefit in specifying a partition performance with an  $R_w$  that is more than 10 dB higher than the  $R_w$  of the doorset within it. As a typical doorset will have an  $R_w$  of 30–35 dB, this means that where there is a door, there is no acoustic benefit in providing partitions with an  $R_w$  higher than 40–45 dB, unless especially high performance doorsets or lobbied doors are used. Requirements for doors are covered in 'Doors'.

Where observation windows are included between adjacent rooms, partitions (including the glass) should ideally achieve the target ratings given in Tables 4 and 5. However, it can be difficult to fit windows that meet the full acoustic specification into the width of partitions. In this case, as a minimum, the glazing configuration alone should achieve an  $R_w$  that is no more than 10 dB below that of the required  $R_w$  for the partition alone. This will reduce the sound insulation by an amount that depends on the size of the observation window in relation to the size of the partition.

If a reduction in sound insulation is likely to cause operational difficulties (for example where a sleep-study observation room is separated from the bedroom by a partition with a large window), the appropriate level of sound insulation should be decided, depending on the circumstances.

This does not apply to windows next to doors or in corridor walls that have doors, where the glazing does not normally need to perform to this extent (due to the reduction in overall sound insulation caused by the doorset). See 'Doors'.

A summary matrix of key areas is given in Table 5. The data in Table 5 shows the installed sound-insulation performance ( $D_{nT,w}$ ) required. For guidance on indicative laboratory performance ratings ( $R_w$ ) to achieve these, see 'Partition and floor sound insulation'.

[Table5.pdf](#)

[Doors](#)

[Room acoustics](#)

[Partition and floor sound insulation](#)

## Long-term accommodation

4068

4115

Spaces used for patients' long-term living and sleeping (for example residential areas of mental health units and residential care homes) should be designed to meet the sound-insulation criteria for "rooms for residential purposes" as defined in Approved Document E of the Building Regulations.

## Doors

4069

4114

Doors are inevitably a weakness in a partition and will reduce the overall acoustic performance of most constructions.

Reasonable acoustic performance cannot be achieved without seals around the whole door perimeter, including threshold and meeting stiles. It is recognised that there can be significant restrictions on the use of door seals; therefore, doors should be sealed as far as practically possible.

Possible conflicts with the desired acoustic performance include opening force (including under emergency conditions), infection control, patient safety (for example if double-swing doors are required) and ventilation regimes. Designers should make an informed decision about the provision of door seals when the other restrictions are considered.

Solid-core door blanks (minimum 21 kg/m<sup>2</sup>) should be used for access from corridors, and these are capable of achieving an acoustic performance in the range  $R_w$  30–35 dB. If seals can be accommodated, the entire doorset is capable of achieving this level of sound insulation. If seals are not to be provided, the overall performance of the doorset will be in the range  $R_w$  20–25 dB.

Doorsets should be designed so that air gaps between the door blank and the frame are closed (for example by using stops on the door frame).

The type of door used for non-sensitive rooms such as storerooms is not acoustically important.

Where doors have glazed vision panels, these should not reduce the sound insulation of the doorset (after taking account of the seals that may be applied around the door).

Even if doors can be sealed on all edges, it is still likely that a determined eavesdropper could overhear conversations when the background noise level outside the room is low and/or the room's occupants are talking in raised voices.

If it is determined that seals to all edges will not be provided, it should be recognised that sound insulation and speech privacy will be reduced further. For this reason, “private” or “confidential” (see Table 3 under 'Sound insulation for rooms') rooms should not be located near areas where there are likely to be people who could overhear. Careful space planning is required to avoid, for example, waiting areas close to doors of consulting rooms or private offices. Sound-masking

could also be considered to improve the level of privacy (see 'Controlling background sound').

Similarly, rooms with “high” or “very high” noise generation should not be located too near to rooms that are classed as “sensitive” or “medium sensitivity” (see Table 3).

The construction of doors and edge detailing also needs to be considered to achieve the required sound insulation between rooms.

Interconnecting doors between consulting rooms should be discouraged on acoustic grounds. The sound insulation will be degraded and speech privacy will not be sufficient.

Doors to “confidential” or “private” rooms should be located as far apart as possible, and not directly opposite each other.

Doors should be fitted with soft-action closers when located in noise-sensitive areas such as speech and language therapy, audiology (see 'ENT and audiology'), and mental health accommodation, as well as general ward, consulting and treatment areas.

If acoustic doorsets with a high rating are used, it may be difficult for a person in the room to hear someone knocking on the door. An intercom may be required for such a room if people regularly need to enter whilst it is in use.

### Sound insulation for rooms

#### Controlling background sound

#### ENT and audiology

## Examples of design conflicts to be considered 4070

The infection control team should be consulted to ascertain whether there is a conflict between the need for seals and the infection control regime.

- \* Doors that need to swing both ways (for example on rooms that must have antibarricade properties) should be considered to find out whether they can accommodate effective acoustic seals.
- \* The possibility of using attenuated “up-and-over” duct links above the ceiling, instead of having gaps under doors, should be considered.
- \* Acoustically-effective seals on meeting stiles need to be either “wiper blade” or compression seals. With some seals, the door may need an opening force that is not consistent with accessibility regulations. Power-assisted doors may be required if these needs cannot be reconciled.
- \* Compression seals require a rebate on the door and thus a door coordinator device, which may cause operational difficulties. The most appropriate type of threshold seals are likely to be drop-down or wiper-blade seals (which would mean that doors need

appropriate hinges), because a raised threshold strip fitted to the floor is likely to cause serious operational difficulties (for example trolley traffic, trip hazards etc).

## Openable windows

4071

4113

Open windows can affect room-to-room sound insulation and lead to privacy problems if external areas are accessible by staff and patients. The design should take account of this so that privacy is achieved. Access to external areas close to openable windows in private areas may therefore need to be controlled.

Care should also be taken to reduce the risk of sound transfer between spaces by direct reflections off open windows (see figure below).

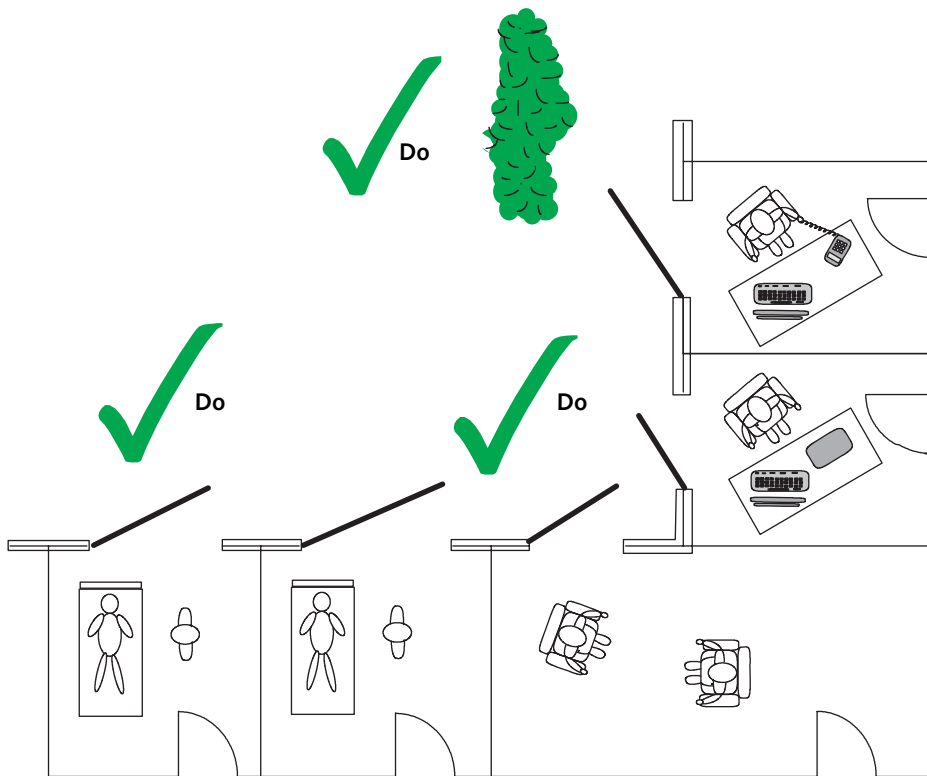
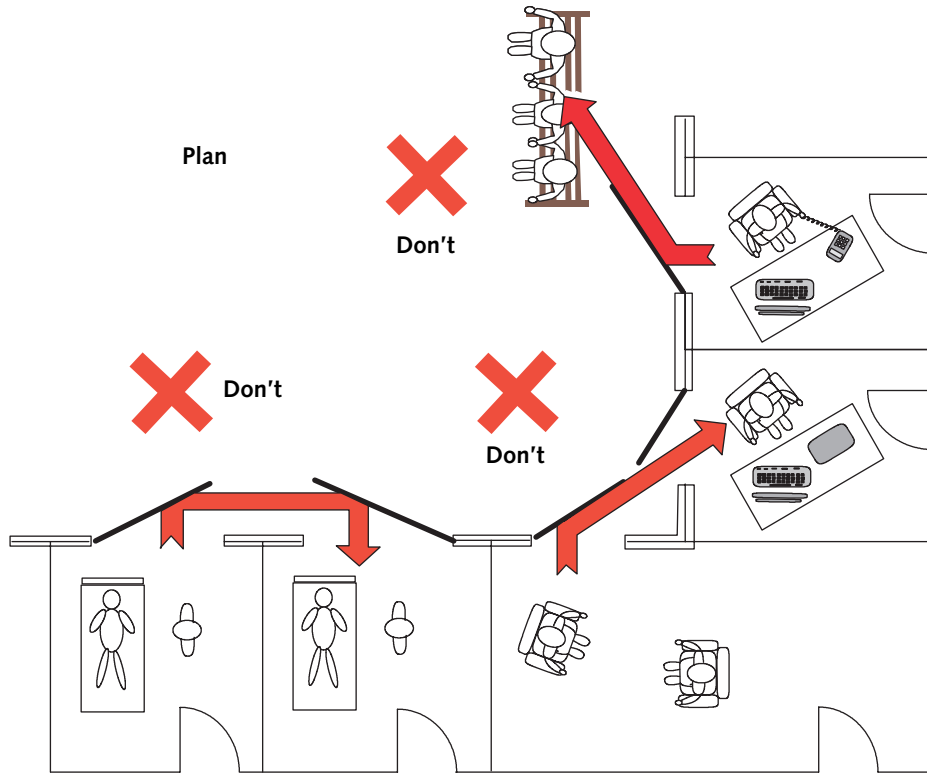

**Reflected sound from openable windows**

## Movable/folding partitions

4072

4112

Movable/folding partitions may be beneficial for operational reasons, but the acoustic performance of these partitions is limited. They are not recommended where speech privacy is required and/or where it will not be acceptable to have any noise disturbance from one room to another.

## Structure-borne sound and lightweight constructions

4073

4111

Activities may result in significant structure-borne sound being transferred to the wall surface (for example showers, toilets, kitchens, workshops). If lightweight constructions are used around these spaces in sensitive locations, the transfer of structure-borne noise should be controlled. This may include the use of twin stud frames, resilient board mountings, or spacing the source of impact away from the wall.

Resilient fixings may be necessary for pipework fixed to lightweight partitions. For example, rainwater pipes and WC waste pipes should not be rigidly fixed.

## Controlling background sound

4074

4110

Background sound levels affect privacy. Where speech privacy is important, high-quality electronic sound-masking systems should be considered. These require careful commissioning to work effectively. A reduction in the required level of sound insulation of up to 5 dB would be appropriate for spaces where such systems are in use, subject to local agreement. A radio or TV can be used to similar effect, although the degree of control possible is lower.

Sound-masking could be considered for:

- \* open-plan clinical areas (for example A&E, multi-cubicle treatment rooms);
- \* multi-bed wards (should have easily adjustable volume for daytime and night-time operation, which can be controlled centrally);
- \* waiting areas;
- \* office areas;
- \* consulting and examination rooms;
- \* areas close to birthing rooms (no down-rating of the partition should be used in this case as very high sound levels are often generated in birthing rooms);
- \* rooms in very quiet sites or areas where intrusive noise levels are low.

## Sound-flanking paths

4075

4107

Sound-flanking around partitions should be controlled so that sound-insulation requirements between rooms can be met. Vertical and horizontal flanking routes should be considered, including the effect of junction details on the overall sound insulation between spaces. Junctions of acoustic partitions with other walls are common potential weaknesses because of flanking sound transfer along the inner skin.

Similar problems can occur with external walls, particularly where partitions and floors about glazing/curtain walling. The internal lining to a lightweight external wall should not be continuous across an acoustic partition or floor. Ribbon or shared windows or full-height glazing cause particular problems and are not recommended for “private” or “confidential” privacy rooms and/or “high” or “very high noise” generation rooms (see diagrams below).

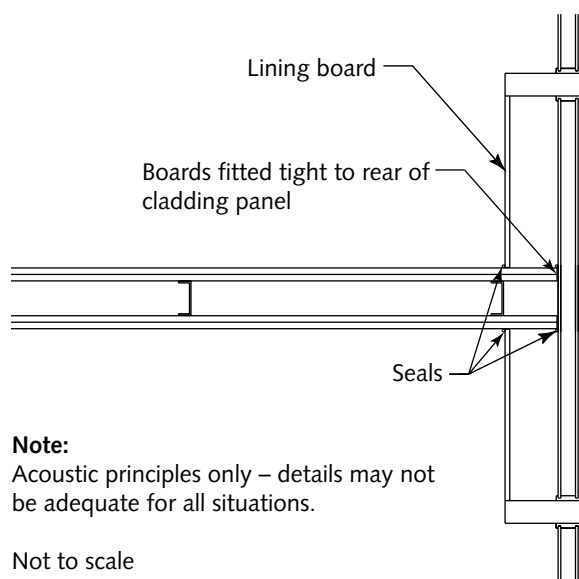

**Schematic of partition meeting cladding panel**

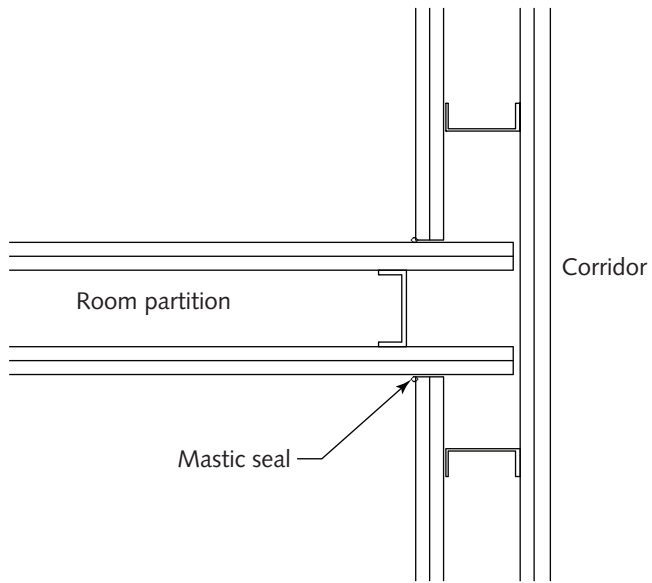

**Typical schematic detail at junction of acoustic partitions with corridor walls (preferred)**

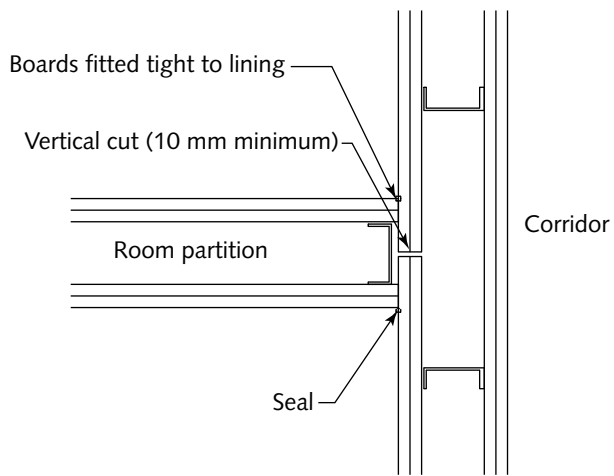

**Typical schematic detail at junction of acoustic partitions with corridor walls (alternative)**

**Scenario**

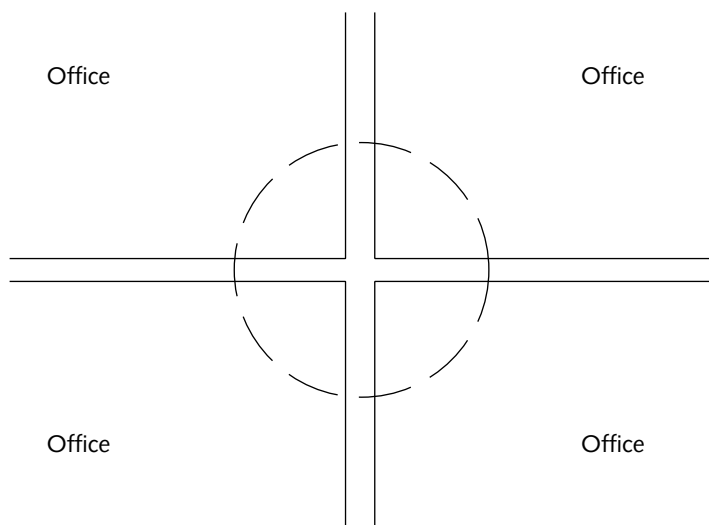

**Detail**

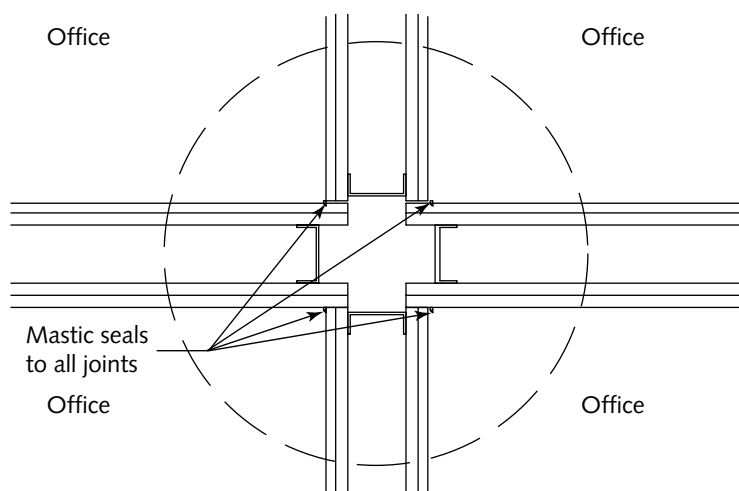

**Typical schematic detail at junction of four acoustic partitions**

Crosstalk attenuation is likely to be required where ducts connect “private”, “confidential” or “sensitive” rooms. Crosstalk attenuation may be provided by proprietary attenuators in the ducts or internally-lined acoustic flexible duct. The amount of crosstalk attenuation required can be reduced by incorporating bends in the duct connecting the grilles, remembering that too many bends will cause pressure drops, and bends which are too tight will cause regenerated noise (see diagrams below).

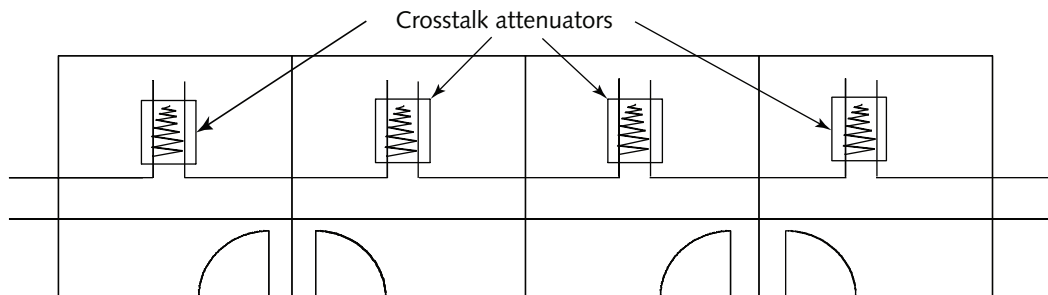

**Typical room layout with main duct penetrating acoustic partitions**

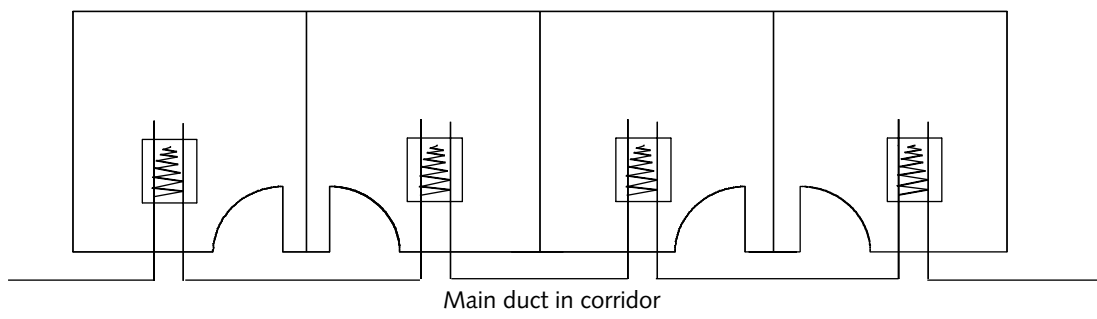

**Typical room layout with main duct in corridor**

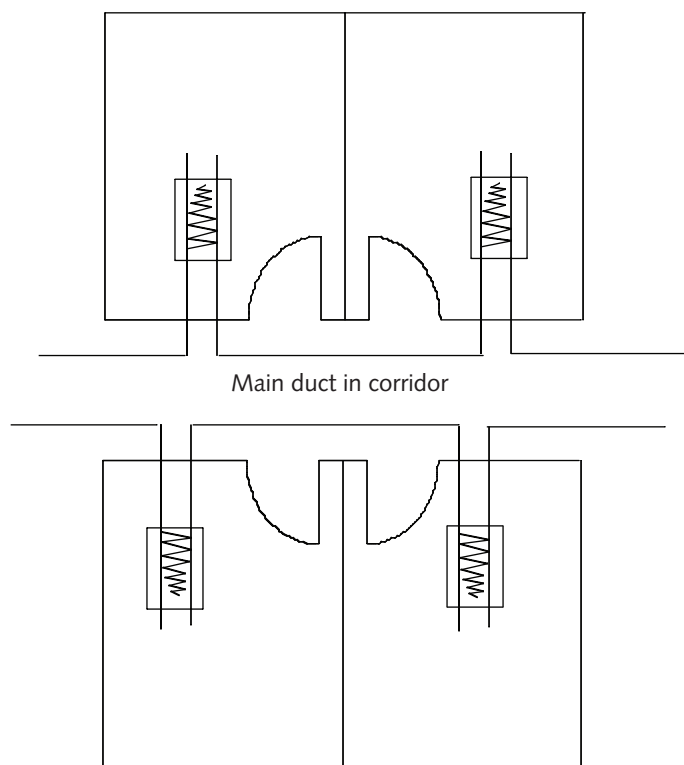

**Typical room layout with rooms both sides of corridor duct**

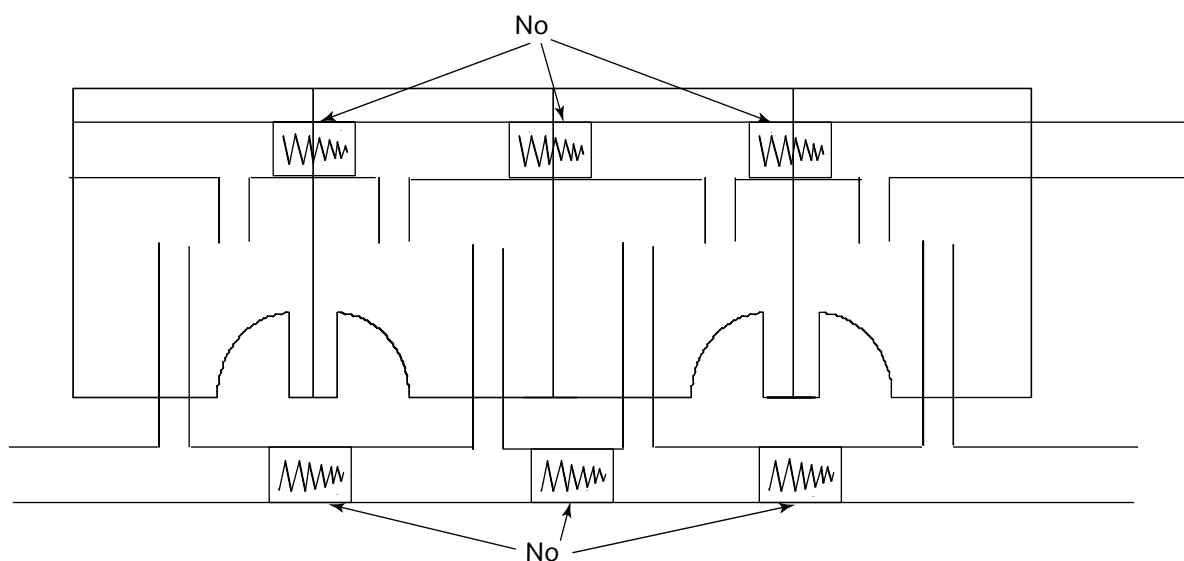

**Layout showing attenuators in series – not recommended**

The junction at the head of partitions should be carefully sealed. Particular care is required where the slab is profiled.

Service penetrations (for example power sockets) and IPS panels can also significantly degrade the sound insulation of a partition, particularly where these are back-to-back. In many cases, the sound insulation required cannot be achieved with back-to-back services (see also 'Services and sound insulation' under 'Internal noise from mechanical and electrical services').

**Internal noise from mechanical and electrical services**

## Height of partitions

4076

4106

For optimum performance, an acoustic partition should extend from slab to soffit (of the floor slab/roof above). If a raised access floor is required, the partition should ideally extend through the floor to the slab below. However, with careful acoustic design and material selection, the partition can be built off a raised floor. This is likely to achieve only the lower levels of sound insulation given in Table 4 under 'Sound insulation for rooms'.

Similarly, if the partition extends only just beyond the ceiling, careful acoustic detailing will be necessary. The ceiling should give sufficient sound insulation (for example solid plasterboard). If under a lightweight roof, the partition should be fixed to a solid underlining, again giving sufficient sound insulation.

### Sound insulation for rooms

## Bathroom pods

4077

4105

Sound insulation between bathroom pods can be significantly reduced by poor designs. For more information, see 'Sound insulation for rooms'.

[Sound insulation for rooms](#)

## Impact sound insulation

4078

4104

Impact noise should be controlled at source wherever possible. Healthcare planning should separate heavily trafficked corridors from sensitive spaces such as wards.

Wards should not be under heavily-trafficked corridors. If this is unavoidable, impact isolation treatments should be provided.

A weighted standardised impact sound pressure level ( $L'_{nT,w}$ ) of 65 dB is considered a reasonable maximum value for floors over noise-sensitive areas. Individual situations that may require extra impact sound insulation should also be considered (for example floors over multi-sensory/Snoezelen rooms).

## Room acoustics

4079

4103

Appropriate acoustic treatments can have a dramatic effect on the acoustic comfort in a room. However, the treatments have to be used with care because of the potential implications of infection control, cleaning, impact damage etc.

Sound-absorbent treatment should be provided in all areas (including all corridors), except acoustically unimportant rooms (for example storerooms etc), where cleaning, infection-control, patient-safety, clinical and maintenance requirements allow.

The absorbent treatment will normally be a ceiling. However, floor finishes (for example carpet) or wall panels may also be considered.

Washable, acoustically-absorbent materials will be required in some areas within the infection-control regime.

Acoustic treatments are likely to be needed where speech intelligibility is a requirement.

Acoustically-absorbent materials should have a minimum absorption area equivalent to a Class C absorber (as defined in BS EN ISO 11654:1997) covering at least 80% of the area of the floor, in addition to the absorption that may be provided by the building materials normally used. If a Class A or B absorbent material is used, less surface area is needed. (See 'Calculation of equivalent absorption area' for an example of how to calculate the absorption area required for materials with different absorption class.)

For rooms requiring optimum acoustic conditions (such as lecture theatres), specialist advice should be sought.

Acoustic absorption is likely to be needed in large open spaces such as atria, particularly in localised areas within it (for example reception areas and cafeterias). A reverberation-time criterion should be agreed depending on the specific requirements for use of the space.

Absorption can take the form of acoustically-absorbent ceiling tiles, perforated boards (for example timber or plaster), acoustic panels fixed to walls or hung from above, soft floor coverings, soft furnishings etc. However, requirements related to fire safety (for example reaction to fire, fire resistance, smoke emissions etc) should be considered.

The need for public address and voice alarm systems to be intelligible may put extra acoustic requirements on the room. (See 'Audio systems for public announcements').

**Calculation of equivalent absorption area**  
**Audio systems for public announcements**

## Audio systems for public announcements

4080

4101

Audio systems should meet a minimum STI of 0.5 or equivalent standard.

The intelligibility should be assessed to BS EN 60268-16 using measurements made at a representative range of evenly spaced locations in relevant spaces.

The audibility and intelligibility of alarms and public address (PA) announcements in noisy or partitioned areas should be assessed, and additional sounders/loudspeakers provided so that messages are audible and intelligible.

In areas where acoustically-absorbent materials cannot be used, adequate intelligibility may be difficult to achieve. Therefore a public address system may not be appropriate for emergency announcements, and other indicators may be necessary. This may also apply in areas with high noise levels (for example plantrooms) or with particularly high standards of sound insulation (for example audiology booths). The needs of people with hearing impairment should also be considered when designing alarm systems.

Additional requirements will apply for systems that are intended for emergency use as set out in IEC 60849.

## Audiology facilities

4081

4102

The acoustic performance of hearing-test rooms within audiology facilities is critical to their clinical performance. Individual test rooms need to be very quiet, at the same time as other hearing-test rooms in the department may create very high noise levels. The rooms should have carefully controlled room acoustics.

Health Building Note 12 – 'Out-patients department – Supplement 3: ENT and audiology clinics, hearing aid centre' recommends detailed acoustic criteria for audiological testing rooms, and should be referred to.

For parts of the audiology department that are not covered by Health Building Note 12 – 'Out-patients department – Supplement 3: ENT and audiology clinics, hearing aid centre', the advice within this manual applies.

**Health Building Note 12 – 'Out-patients department – Supplement 3: ENT and audiology clinics, hearing aid centre'**

## Vibration

4082

4289

Vibration caused by plant, medical equipment and activities within the building should not affect the use of the building. Some medical equipment is sensitive to vibration, and so are people. Excessive vibration can lead to adverse comment from the building occupants and can impair the operation of sensitive equipment.

A competent structural engineer should design the building structure and floors so that the criteria in 'Continuous vibration' and 'Intermittent vibration' below are achieved. The criteria have a low probability of adverse comment with respect to human comfort. They have been shown to be adequate for medical equipment commonly used in wards and treatment rooms.

Requirements for particularly sensitive equipment are considered in 'Vibration-sensitive equipment' below.

Plant vibration should be assessed in conjunction with the structural vibration characteristics in order to meet the vibration criteria. Structure-borne noise from plant also needs to be designed so that mechanical-service noise limits (Table 2 under 'Internal noise from mechanical and electrical services') are met.

Worked examples of vibration assessment are given in 'Worked examples of vibration performance criteria'.



**Audiology testing room (photograph courtesy of Industrial Acoustics Company)**

**Worked examples of vibration performance criteria**  
**Internal noise from mechanical and electrical services**

## **Continuous vibration**

**4083**

Continuous vibration should be assessed in terms of the root mean square (RMS) value (averaged over one second) of the frequency-weighted acceleration on the floors of occupied areas.

The frequency weighting should be  $W_g$  as specified in BS 6841.

The base value of frequency-weighted acceleration is  $0.005 \text{ m s}^{-2}$ .

Multiplying factors relative to the specified base values are found by dividing the weighted RMS acceleration by the base value.

Multiplying factors for different types of accommodation corresponding to a low probability of adverse comment are as follows:

Operating theatre, precision laboratory, audiometric testing booth	1
Wards	2
General laboratories, treatment areas	4
Offices, consulting rooms	8

## **Intermittent vibration**

**4084**

Intermittent vibration may conservatively be assumed to be continuous.

Alternatively, if the duration and frequency of occurrence of events are known, the

vibration dose value (VDV) may also be used. VDV is defined in BS 6472, and values corresponding to a low probability of adverse comment for different types of accommodation are given below.

Wards	0.2 m s <sup>-1.75</sup>
General laboratories, treatment areas	0.4 m s <sup>-1.75</sup>
Offices, consulting rooms	0.8 m s <sup>-1.75</sup>

In the case of operating theatres and precision laboratories, it is not appropriate to make allowance for intermittent events, and the maximum frequency-weighted acceleration should be within the limits set for continuous vibration.

### Vibration-sensitive equipment

4085

Some specialist medical equipment (for example scanners and some microscopes) is particularly sensitive to vibration. Meeting the vibration criteria above does not guarantee that such equipment will not be affected by vibration.

A specialist should assess the suitability of a proposed site for such equipment. This will require reference to vibration performance requirements supplied by the manufacturer of the equipment. The specialist should consider all likely sources of vibration, which might include footfalls, plant, nearby vehicular traffic or railways, loading, unloading and other facilities-management activities.

It should also be noted that laboratory furniture can often amplify ambient vibration, depending on design, and special bench designs may be required for sensitive microscopes, balances etc.

# Construction noise and vibration

4036

4093

A strategy should be drawn up to control construction noise and vibration where this is likely to affect an existing healthcare facility or residential areas (see BS 5228).

Each project will have different and specific requirements, so only outline information can be given here.

The strategy should include:

- \* policy for operating hours;
- \* policy for planning noisy activities and agreeing systems for liaison between contractors and healthcare staff;
- \* policy for emergency situations where work has to proceed outside the agreed time slots;
- \* acoustic treatment to fixed plant;
- \* location of temporary access roads and access to the site;
- \* equipment for cutting and breaking concrete;
- \* control of vibration transfer from construction areas to occupied areas;
- \* use of temporary screening;
- \* unacceptable construction equipment (for example driven piles, untreated temporary generators etc);
- \* noise-monitoring policy.

# Temporary healthcare facilities

4037

4095

Temporary facilities provided during the construction process ideally need to meet the standards set out in this manual as far as practicable. There may be practical limitations to the acoustic performance achievable within some types of temporary accommodation.

It is important to understand the implications of this and agree specific acoustic requirements. Areas where it is not possible to achieve the standards within this manual should be identified, and a decision made on the type of temporary building required.

# Refurbished accommodation

4038

4097

Refurbished buildings ideally need to meet the criteria set out in this manual. There may be practical limitations to the acoustic performance achievable within existing buildings.

It is important to investigate what elements of the existing building are part of the refurbishment and agree specific acoustic requirements. Areas where it is not possible to achieve the criteria within this manual should be identified, and a decision made on the extent of the refurbishment.

4098

## Example 1

Flanking sound in retained structures may limit the sound insulation achievable between rooms. Unless existing structures, services etc are also to be upgraded, there can be limited benefit in providing high performance partitions.

## Example 2

If an existing ventilation system is to be retained without any changes, the noise criteria in Table 2 (see 'Internal noise from mechanical and electrical services') may not be achievable.

## Example 3

If the existing windows are to be retained, the intrusive noise criteria given in Table 1 (see 'Internal noise levels from external sources') may not be achievable.

[Internal noise from mechanical and electrical services](#)

[Internal noise levels from external sources](#)

# Inspecting works during construction

4039

4099

To ensure that the construction is acoustically robust, an acoustic specialist should monitor the installation by regular visits to site. The specialist should ensure that workmanship is of sufficient standard to meet the target acoustic performances, and help train site personnel to spot and deal with acoustic issues. This provides opportunities to improve construction methods before acoustic testing.



Site inspection (photograph courtesy of Sound Research Laboratories Ltd)

# Testing and validation

4040

4118

A testing programme should be agreed before construction. This should include the following:

- \* Sound insulation
- \* Noise levels generated by mechanical and electrical services
- \* Intrusive noise
- \* Audio system intelligibility
- \* Environmental noise
- \* Audiometric testing rooms
- \* General comments
- \* Failure to meet criteria
- \* Commissioning results

## Sound insulation

4100

4179

Test procedures should be in accordance with BS EN ISO 140-4 and BS EN ISO 140-7.

Tests should be carried out by a body accredited by the United Kingdom Accreditation Service (UKAS) or the Association of Noise Consultants (ANC) for doing such tests.

Performance should be rated in accordance with BS EN ISO 717-1 and BS EN ISO 717-2.

- \* Airborne sound insulation testing of a random selection of partition and floor types: to include typical wards, consulting rooms and maternity facilities as a minimum. These tests should be done at the earliest opportunity (preferably in a complete mock-up on site) to identify potential weaknesses before these are replicated in numerous areas.
- \* Impact sound insulation testing of a random selection of floor types: to include typical floors over wards as a minimum, plus other sensitive areas identified during the design as needing additional impact sound insulation.
- \* A typical test regime would be airborne tests on eight partitions of each construction type plus airborne and impact tests on four floors of each construction type: to include a selection of flanking arrangements (for example internal walls, external cladding, masonry walls).

**United Kingdom Accreditation Service (UKAS)**

**Association of Noise Consultants (ANC)**

## Noise levels generated by mechanical and electrical services

4121

4120

Services should be operating at their maximum normal design duty before the following checks take place:

- \* noise levels should be measured in randomly selected areas, particularly those close to plantrooms. This should include measurements of noise levels during start-up where this is a noisy operation;
- \* testing should include measurements in at least five clinical rooms served by each ventilation system;
- \* the rooms selected should have the lowest NR criterion for that system and/or be closest to the branch off the main duct. In addition, measurements should be made in representative clinical rooms adjacent to plantrooms and external plant areas;
- \* tests should be undertaken before medical equipment is installed or operational, unless there has been agreement that this equipment should also meet the criterion;
- \* tests should be carried out when the rooms are furnished but unoccupied. If it is not possible to test when rooms are furnished, an allowance may be made for the expected difference in reverberation time when the room becomes furnished;
- \* reductions in the number of tests may be acceptable if, for example, there is repetition of design;
- \* the measurements in each room should be spatially averaged, with each measurement position representing the use of the room (minimum of three measurements per room);
- \* the measurement time period selected should represent the use of the room and/or the operation of the plant/equipment;
- \* other test requirements should be taken from the ANC's guidelines – 'Noise measurement in buildings'.

Association of Noise Consultants (ANC)

## Intrusive noise

4123

4122

The following measurements should be taken from a sample of rooms during daytime and night-time:

- \* a typical requirement would be for spatially averaged measurements in representative rooms on each façade (and at a number of floor levels if the external noise level varies with height on the façade);
- \* during measurements, windows and trickle ventilators should be open as required to achieve the required amount of ventilation;
- \* measurements should be made for a period of time that represents the use of the room and the external noise sources;
- \* the measurements in each room should be spatially averaged, with each measurement position representing the use of the room (a minimum of three measurements per room);
- \* if the external noise sources are sufficiently constant, measurement time periods of less than one hour are acceptable;
- \* tests should be done when the rooms are furnished but unoccupied;
- \* if it is not possible to test when rooms are furnished, an allowance may be made for the expected difference in reverberation time when the room becomes furnished;
- \* other test requirements should be taken from the ANC's guidelines – 'Noise measurement in buildings';
- \* due to the practical problems for measuring rain noise on a completed building, it will normally be acceptable to prove the performance by calculations based on the laboratory-measured rain-noise data for the roof system used.

**Association of Noise Consultants (ANC)**

## Audio system intelligibility

4125

4124

An STI to BS EN 60268-16 (or equivalent parameter and standard as identified in 'Sporadic events' and 'Rain noise' under 'Internal noise levels from external sources') should be measured for each audio system. The following should be taken into account:

- \* reductions in the number of tests may be acceptable if, for example, there is repetition of design;
- \* measurements should be made at locations that represent the room use;
- \* tests should be done when the rooms are furnished but unoccupied;
- \* if it is not possible to test when rooms are furnished, an allowance may be made for the expected difference in reverberation time when the room becomes furnished;
- \* other test requirements should be taken from the ANC's guidelines – 'Noise measurement in buildings'.

Internal noise levels from external sources  
Association of Noise Consultants (ANC)

## Environmental noise

4127

4126

All plant should be operating at its maximum normal design duty. The following should also be taken into account:

- \* suitable measurements should be made to check compliance with planning conditions etc as appropriate;
- \* appropriate locations and times should be selected, noting that measurements will probably be needed at night;
- \* where agreement has been made for relaxing noise criteria for emergency plant, it should be tested separately.

## Audiometric testing rooms

4181

4182

Airborne sound insulation, impact sound isolation, intrusive noise and service-noise measurements should be carried out in all audiology rooms/booths:

- \* testing should be done when the facility is operational, otherwise worst-case expected operational noise levels should be re-created;
- \* specialist sound-level-measuring equipment will be needed to measure low noise levels in testing rooms;
- \* due to the practical limitations of measuring accurate reverberation times in small rooms (particularly at low frequencies), normally the performance should be proved by calculations based on the laboratory-measured absorption data for the materials/furnishings used.

## General comments

4184

4183

Noise and vibration measurements should be made using suitable instrumentation in accordance with BS EN 61672 Parts 1 and 2, following the British and International standards or other appropriate standards where relevant. The equipment used should have calibration certification traceable to national standards.

Personnel chosen to carry out the commissioning tests should be suitably trained in the test procedures and relevant Standards.

## Failure to meet criteria

4186

4185

In the event of a failure to meet the project's acoustic criteria:

- \* elements that do not meet the agreed performances set out in the acoustic strategy document should be remedied;
- \* test failures that indicate poor workmanship or design should normally result in testing of other areas, to show whether they meet the standards;
- \* the responsibility for failures may be due to more than one party, depending on individual circumstances;
- \* an acoustic specialist representing interested parties may decide to allow small individual failures, and this will depend on individual circumstances. Generally, 1 dB or 2 dB is considered negligible in acoustic terms, as this difference is undetectable to normal human hearing. However, this does not justify planned under-design of the building.

## Commissioning results

4189

4187

The following measurement results should be presented:

- \* airborne-sound-insulation ratings (in terms of  $D_{nT,w}$ );
- \* impact sound insulation (in terms of  $L'_{nT,w}$ );
- \* noise levels generated by mechanical services (in terms of NR);
- \* intrusive noise levels (in terms of  $L_{Aeq,1hr}$  and  $L_{Amax,t}$  as appropriate);
- \* speech intelligibility ratings (in terms of STI or equivalent);
- \* environmental noise levels (in terms of the appropriate parameter);
- \* audiometric testing rooms – all results as required in 'Audiometric testing rooms';
- \* comparison of all commissioning results with design criteria, statement of acceptability, details of remedial measures and subsequent changes in results.

### Audiometric testing rooms

# Checklists

4041

4203

The following are suggested as an initial check of the most important acoustic issues, but are not intended to be an exhaustive list.

## Checklists

The following are suggested as an initial check of the most important acoustic issues, but are not intended to be an exhaustive list.

Planning	Check
Imaging equipment is located on a ground-bearing slab where possible (airborne noise and vibration can be generated)	
Vibration-sensitive equipment is located away from sources of vibration and structures with appropriate vibration characteristics	
The helipad is located as far away from local residences and ward areas as possible (within operational constraints)	
Energy centre, generators, service yards, delivery areas are located away from sensitive areas within and outside the site boundary	
Noisy roof plant is not over sleeping areas, and noise to atmosphere outside the site is appropriately controlled	
Waiting areas are not next to doors into "private", "confidential" or "sensitive" areas	
"Sensitive" or "medium sensitivity" areas with openable windows are located away from noisy areas or areas where external seating is provided	
Heavily trafficked corridors are not above sensitive spaces	
Interconnecting doors between private areas are avoided	
Laundries, sterile services departments etc are located away from sensitive areas	
Noise-sensitive accommodation is under a roof that will adequately control rain noise	
Internal acoustics	Check
There is adequate sound-absorption provision in all occupied spaces	
Ceiling tiles are sufficiently absorbent and cleanable	
Sound-absorbent materials used in acoustic treatments have encapsulated acoustic materials where necessary	
Sound absorption is provided in patient areas where this does not conflict with cleaning and maintenance strategies	
Atria are provided with acoustic treatment	
Absorption is provided around nurse stations to minimise noise transfer	
Internal sound insulation and privacy	Check
"Confidential" or "private" rooms with openable windows are located and designed to minimise sound directly reflecting into other open windows	
External areas near openable windows in "private", "confidential" or "sensitive" rooms are not easily accessible from outdoors	
Crosstalk via ducting has been controlled	
Noise transmission via flanking elements has been controlled (for example, internal linings on external walls are not continuous between rooms; partition junctions have been designed to minimise flanking)	
Full-height partitions (that is, to the soffit) have been provided where required	
Sources of structure-borne sound are adequately controlled	
Sound-masking has been considered for high-privacy areas, with adjustable volume in multi-bed wards	
Potential conflicts for door requirements have been considered and resolved	
Waiting areas are not immediately outside "confidential" or "private" rooms	
Acoustic doors are operable by disabled users	
Impact noise has been controlled where necessary	

[Checklist.pdf](#)

# Partition and floor sound insulation

4042

4207

The target sound insulation between rooms is specified in terms of the in-situ room-to-room weighted standardised level difference  $D_{nT,w}$ . Partition constructions required, however, should be determined based on laboratory-tested weighted sound-reduction index values  $R_w$ . The difference between the two values depends on a number of factors, including:

- \* the surface area of the separating wall/floor ( $m^2$ );
- \* the volume of the receiving room ( $m^3$ );
- \* the standard of workmanship;
- \* the acoustic integrity of flanking constructions, junction details and service penetrations.

As described in the text, values of 7 dB (lightweight construction) and 4 dB (masonry construction) are typical to allow for a reasonable standard of workmanship and a small amount of flanking (that is, a lightweight partition on site is likely to be at least 7 dB below its laboratory-tested performance).

a. To calculate the  $R_w$  required to meet a given  $D_{nT,w}$ , the following relationships should be used:

(i) For lightweight walls/floors:

$$R_w \text{ is equivalent to } D_{nT,w} - 10 \log (T/T_r) + 10 \log (ST/0.16V) + 7.$$

(ii) For masonry walls/floors:

$$R_w \text{ is equivalent to } D_{nT,w} - 10 \log (T/T_r) + 10 \log (ST/0.16V) + 4.$$

Where:

$S$  = common area of separating element being considered ( $m^2$ );

$V$  = volume of receiving room ( $m^3$ );

$T$  = measured reverberation time in receiver room as per BS EN ISO 140-4;

$T_r$  = the reference reverberation time, to be taken as 0.8 seconds.

This simplifies to:

(i) For lightweight walls/floors:

$R_w$  is equivalent to  $D_{nT,w} + 10 \log (S/V) + 14$ .

(ii) For masonry walls/floors:

$R_w$  is equivalent to  $D_{nT,w} + 10 \log (S/V) + 11$ .

b. For cuboid-shaped receiving rooms, where the separating element is the whole of one surface, this can be further simplified to:

(i) For lightweight walls/floors:

$R_w$  is equivalent to  $D_{nT,w} - 10 \log d + 14$ .

(ii) For masonry walls/floors:

$R_w$  is equivalent to  $D_{nT,w} - 10 \log d + 11$ .

Where:

$d$  = dimension of receiving room perpendicular to separating element being considered (height of room for floor, width or depth of room for partitions, depending on which is perpendicular to the partition being considered).

For very small receiving rooms that do not produce noise and are not sensitive to noise (such as a linen store), the sound insulation derived from the above equations is unnecessarily high, owing to the small dimensions. Provided the receiving room is not normally occupied (and when it is, only by staff), the receiving room may be assumed to have the same dimensions as the source room. If someone were to spend time in the linen store (in this example), the level of privacy from the adjacent room would be low. See the detailed examples that follow and the figures below for more details.

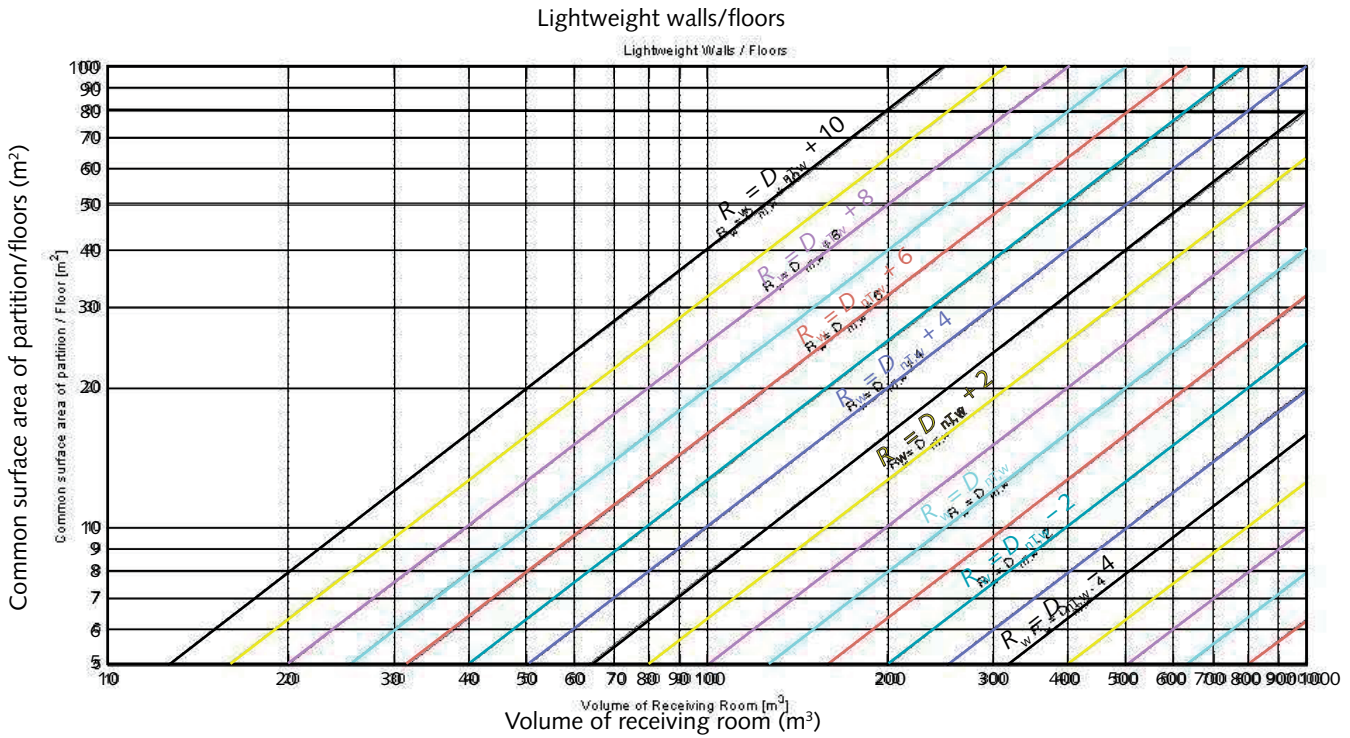

Figure A1 Calculation of  $R_w$  from  $D_{nT,w}$  for lightweight constructions

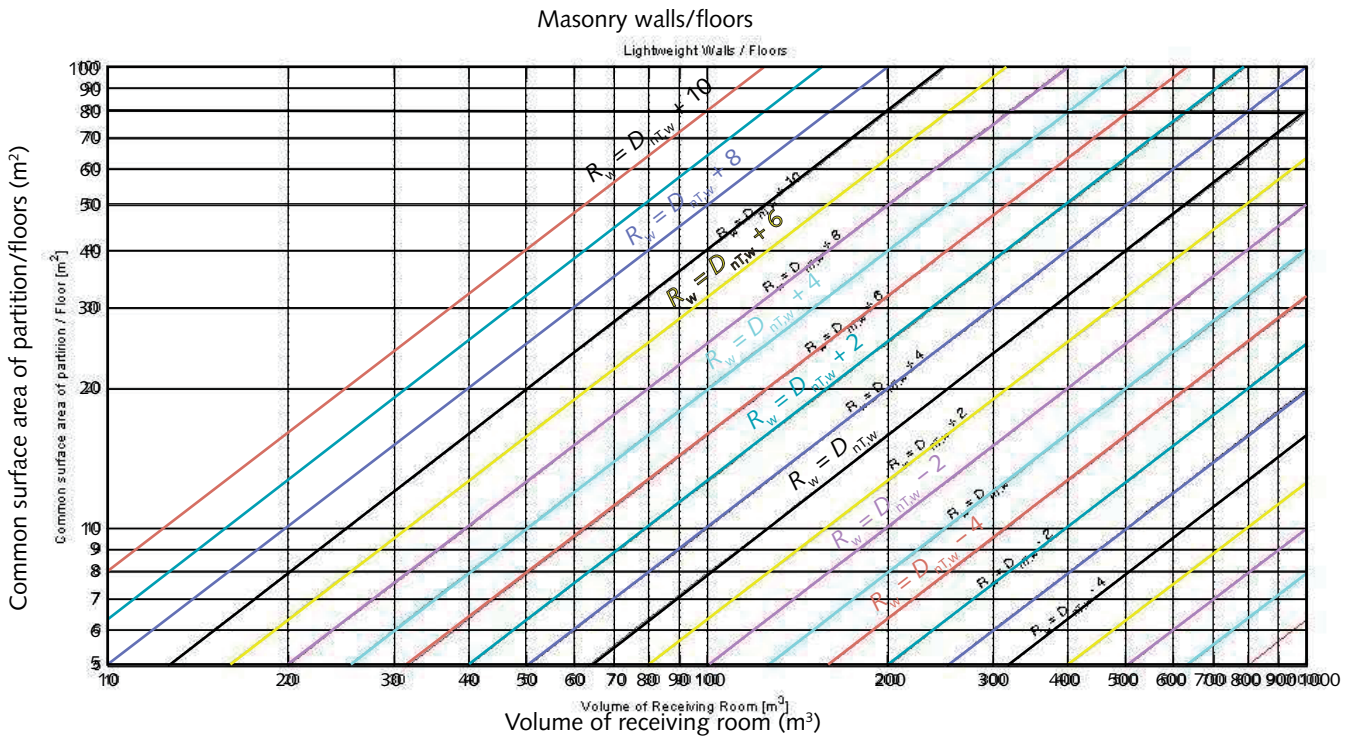

Figure A2 Calculation of  $R_w$  from  $D_{nT,w}$  for masonry construction

## Example 1. Lightweight partition – absorbent ceilings

4213

Consulting room 1 is next to consulting room 2. The lightweight partition between the rooms is 11 m<sup>2</sup>; this area is common to both consulting rooms. Each consulting room has a volume of 34 m<sup>3</sup>, and both rooms have a Class C ceiling covering at least 80% of the floor area.

**Consulting room 1 to consulting room 2 (from Tables 3 and 4 under 'Sound insulation for rooms'):**

Source: Confidential, typical

Receiver: Medium

$D_{nT,w}$  required: 47 dB.

Using Figure A1 or equations in the paragraph above (for lightweight constructions):

$$R_w = D_{nT,w} + 9 \text{ dB}$$

$$= 56 \text{ dB.}$$

From consulting room 2 to consulting room 1:

Calculation is the same as above, so:

$$R_w = 56 \text{ dB.}$$

A partition rated at  $R_w = 56$  dB (or above) should be selected from manufacturers' certified test data.

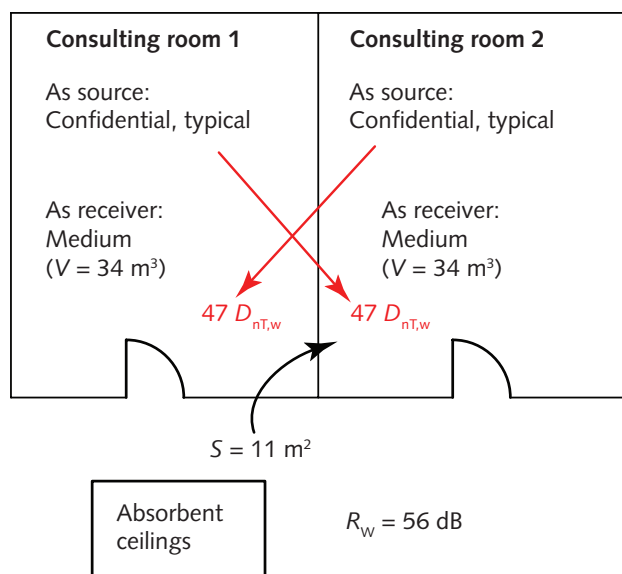

Figure A3 Example 1

### Sound insulation for rooms

#### Example 2. Concrete floor – absorbent ceilings 4219

Bedroom A is above part of bedroom B. The common area of concrete floor between the rooms is 20 m². Bedroom A has a volume of 72 m³ and bedroom B has a volume of 60 m³. Both rooms have a Class C ceiling covering at least 80% of the floor area.

#### Bedroom A to bedroom B (from Tables 3 and 4 under 'Sound insulation for rooms'):

Source: Confidential, typical

Receiver: Medium

$D_{nT,w}$  required: 47 dB.

Using Figure A2 or equations above (for masonry constructions):

$S = 20$  m² and  $V = 60$  m³

$R_w = D_{nT,w} + 6$  dB

= 53 dB.

#### From bedroom B to bedroom A:

Source: Confidential, typical

Receiver: Medium

$D_{nT,w}$  required: 47 dB

Using Figure A2 or equations above (for masonry constructions):

$S = 20 \text{ m}^2$  and  $V = 72 \text{ m}^3$

$R_w = D_{nT,w} + 5 \text{ dB}$

= 52 dB.

A floor/ceiling construction rated at  $R_w = 53 \text{ dB}$  (or above) should be selected.

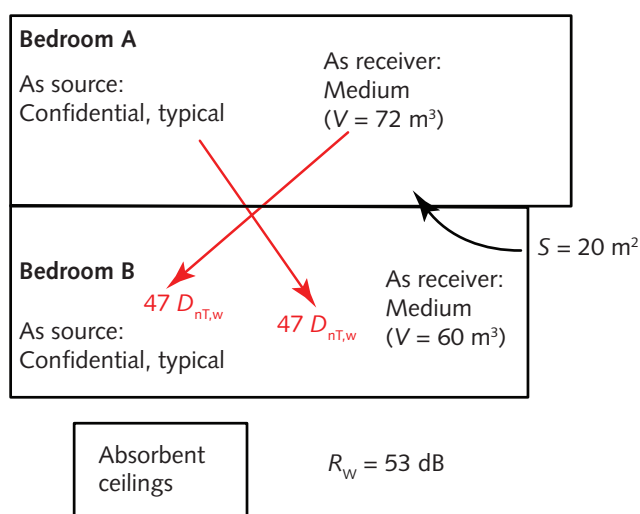

Figure A4 Example 2

Sound insulation for rooms

**Example 3. Lightweight partition – non-absorbent ceilings**

4222

Operating theatre 1 is next to operating theatre 2. Due to hygiene and washability requirements, it is agreed that the theatres cannot accommodate acoustic absorption material. The lightweight partition between the rooms is  $15 \text{ m}^2$  and this area is common to both theatres. Each theatre has a volume of  $60 \text{ m}^3$ .

**Theatre 1 to theatre 2 (from Tables 3 and 4 under 'Sound insulation for rooms'):**

Source: Private, typical

Receiver: Sensitive

$D_{nT,w}$  required:  $47 \text{ dB} + 3 \text{ dB}$  (due to lack of absorption material) =  $50 \text{ dB}$ .

Using Figure A1 or equations above (for lightweight constructions):

$$R_w = D_{nT,w} + 8 \text{ dB}$$

$$= 58 \text{ dB.}$$

**Theatre 2 to theatre 1 (from Tables 3 and 4):**

Source: Private, typical

Receiver: Sensitive

$D_{nT,w}$  required: 47 dB + 3 dB (due to lack of absorption material) = 50 dB.

Using Figure A1 or equations above (for lightweight constructions):

$$R_w = D_{nT,w} + 8 \text{ dB}$$

$$= 58 \text{ dB.}$$

A partition rated at  $R_w = 58 \text{ dB}$  (or above) should be selected from manufacturers' certified test data.

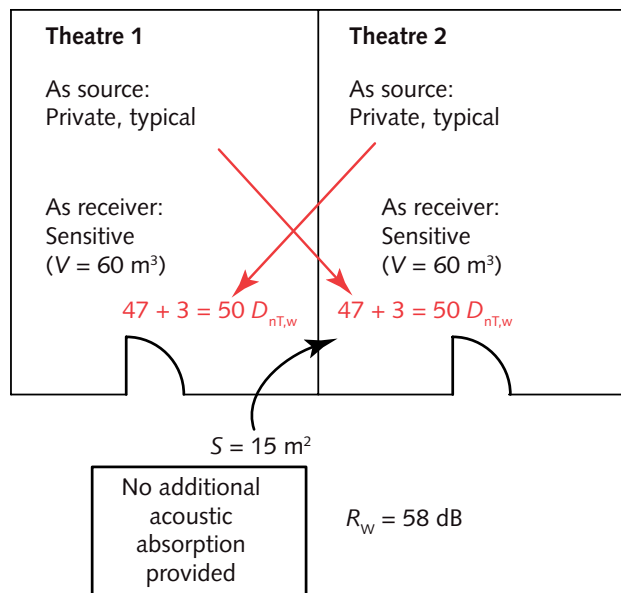

Figure A5 Example 3

### Sound insulation for rooms

## Example 4. Lightweight partition – absorbent ceilings – different room uses

4223

A dirty utility is next to a consulting room. The dirty utility has a volume of  $18 \text{ m}^3$ ; the consulting room volume is  $60 \text{ m}^3$ , and the common lightweight partition

between them is 6 m<sup>2</sup>. Both rooms have a Class C ceiling covering at least 80% of the floor area.

**Consulting room to dirty utility (from Tables 3 and 4 under 'Sound insulation for rooms'):**

Source: Confidential, typical

Receiver: Not sensitive

$D_{nT,w}$  required: 47 dB.

Using Figure A1 or equations above (for lightweight constructions):

$S = 6 \text{ m}^2$  and  $V = 18 \text{ m}^3$

$R_w = D_{nT,w} + 9 \text{ dB}$

= 56 dB.

**Dirty utility to consulting room (from Tables 3 and 4):**

Source: Not private, high

Receiver: Medium

$D_{nT,w}$  required: 42 dB.

Using Figure A1 or equations above (for lightweight constructions):

$S = 6 \text{ m}^2$  and  $V = 60 \text{ m}^3$

$R_w = D_{nT,w} + 4 \text{ dB}$

= 46 dB.

A partition rated at  $R_w = 56 \text{ dB}$  (or above) should be selected from manufacturers' certified test data.

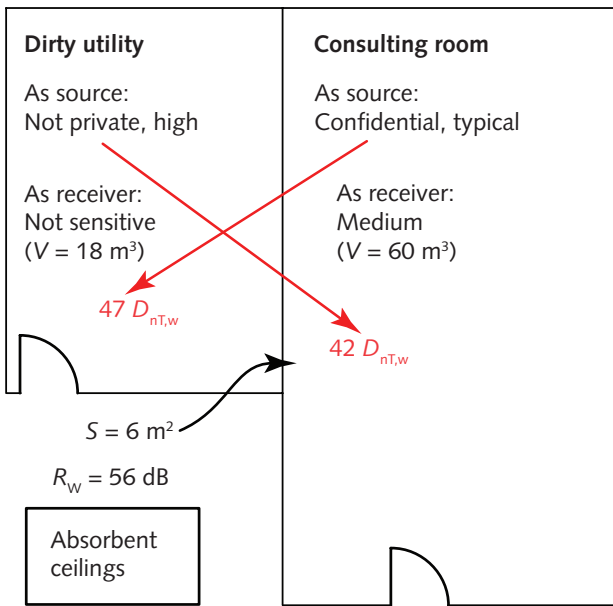

Figure A6 Example 4

Sound insulation for rooms

**Example 5. Lightweight partition – absorbent ceilings – small non-sensitive room** 4225

A bedroom is next to a linen store. The linen store has a volume of 10 m³; the bedroom's volume is 50 m³ and the common lightweight partition between them is 3.5 m². Both rooms have a Class C ceiling covering at least 80% of the floor area.

**Bedroom to linen store (from Tables 3 and 4 under 'Sound insulation for rooms'):**

Source: Confidential, typical

Receiver: Not sensitive

$D_{nT,w}$  required: 47 dB.

Using Figure A1 or equations above (for lightweight constructions):

$S = 3.5 \text{ m}^2$  and  $V = 10 \text{ m}^3$

$R_w = D_{nT,w} + 9 \text{ dB}$

= 56 dB.

**Linen store to bedroom (from Tables 3 and 4):**

Source: Not private, low

Receiver: Medium

$D_{nT,w}$  required: No rating

Following the normal rules set out, a partition rated at  $R_w = 56$  dB (or above) should be selected from manufacturers' certified test data. However, the text above describes what to do in this situation. Assuming that the linen store is not normally occupied, and when it is, by staff only, the dimensions of the receiving room can be taken to be the same as those of the source room:

**Bedroom to linen store (from Tables 3 and 4):**

Source: Confidential, typical

Receiver: Not sensitive

$D_{nT,w}$  required: 47 dB.

Using Figure A1 or equations above (for lightweight constructions):

$S = 3.5 \text{ m}^2$  and  $V = 50 \text{ m}^3$

$R_w = D_{nT,w} + 2 \text{ dB}$

$= 49 \text{ dB}$ .

This gives a more realistic requirement for  $R_w$  of 49 dB.

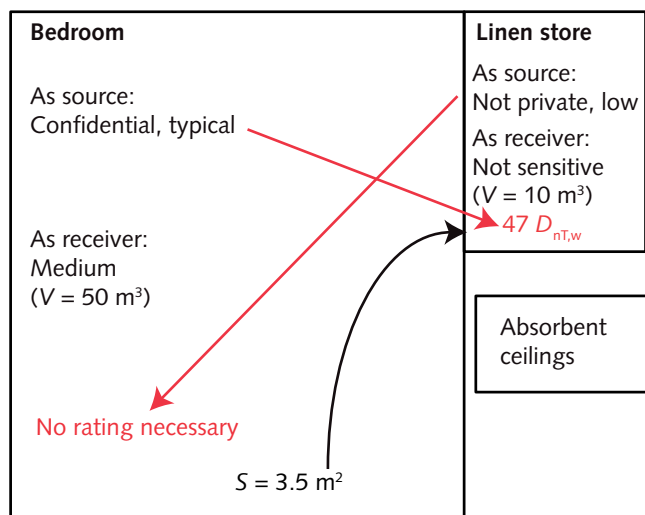

$R_w = 49$  dB following recommended calculation methods for small, non-occupied, non-sensitive rooms

Figure A7 Example 5

Sound insulation for rooms

# Calculation of equivalent absorption area

4043

4227

'Room acoustics' describes how acoustic absorption should be incorporated in occupied spaces to enhance the acoustic environment.

## Room acoustics

### Method A

4228

Acoustically-absorbent materials should have a minimum absorption area equivalent to a Class C absorber covering an area of at least 80% of the room's floor area. It will normally be convenient to cover the ceiling with this absorption, provided suitable ceiling tiles are selected that meet hygiene and washability requirements.

### Method B

4229

If materials with a better absorption class (Class A or Class B) are used, the required minimum surface area of the absorption material is reduced. The required surface area of material should be calculated as follows:

Room floor area =  $A$  m<sup>2</sup>.

Minimum 80% to be covered with Class C absorber =  $0.8A$ .

Absorption area required = Class C absorption coefficient  $\times 0.8A$  at octave band frequency.

Required surface area of absorbent material =

Absorption area required

Absorption coefficient of selected material

The following example illustrates the above procedure.

**The concrete soffit of an office is being left exposed, and an absorbent ceiling cannot be fitted. The floor area of the office is 25 m<sup>2</sup>. What surface area of an alternative absorbent material should be used?**

<b>Step 1. Calculate the minimum absorption area required</b>						<b>Line</b>
Floor area of 25 m <sup>2</sup> × 0.8 = 20 m <sup>2</sup>						<b>1</b>
Octave band frequency (Hz)	250	500	1000	2000	4000	<b>2</b>
Absorption coefficient of typical healthcare Class C ceiling	0.35	0.55	0.7	0.8	0.9	<b>3</b>
20 m <sup>2</sup> × Class C coefficient = absorption area required (m <sup>2</sup> )	7	11	14	16	18	<b>4</b>
<b>Step 2. Calculate the absorption area provided by selected materials</b>						
Thin carpet (25 m <sup>2</sup> ) absorption coefficient	0.03	0.06	0.15	0.30	0.40	<b>5</b>
Thin carpet absorption area (25 m <sup>2</sup> × line 5)	0.75	1.5	3.75	7.5	10	<b>6</b>
<b>Step 3. Determine whether there is sufficient absorption area</b>						
Extra absorption area required (m <sup>2</sup> ): (line 4 – line 6)	6.25	9.5	10.25	8.5	8	<b>7</b>
<b>Step 4. Try adding extra absorption with wall panels to make up shortfall</b>						
Wall-panel absorption coefficient	0.65	1.0	1.0	1.0	0.95	<b>8</b>
Required surface area of wall panel = Extra absorption area required/ Wall panel absorption coefficient [that is, (line 7 ÷ line 8)]	9.6	9.5	10.25	8.5	8.4	<b>9</b>
<b>Therefore, in this example, 10.25 m<sup>2</sup> of wall panel with the stated absorption coefficient is required</b>						

**Calculation of equivalent absorption area**

# Worked examples of vibration performance criteria

4044

4233

A waste compactor runs four times a day for three minutes. The compactor will produce vibration that affects a nearby room. The structural engineer calculates that the vibration will be sinusoidal with a frequency of 16 Hz and an RMS acceleration of  $0.05 \text{ m s}^{-2}$ . [Structural engineers might use various methods to calculate the acceleration levels in a particular building. The most appropriate method should be determined in each case.] There will be no other significant vibration in the room. What can the room be used for?

- \* Step 1 – calculate the frequency-weighted acceleration level:

RMS acceleration  $\times$  frequency weighting of  $W_g$  (BS 6841) at 16 Hz

$$= 0.05 \text{ m s}^{-2} \times 0.500$$

$$= 0.025 \text{ m s}^{-2}$$

- \* Step 2 – calculate the multiplying factor:

Frequency-weighted acceleration level

Base value ( $0.005 \text{ m s}^{-2}$ )

$$= 0.025 \text{ m s}^{-2}$$

$$0.005 \text{ m s}^{-2}$$

$$= 5$$

Although the vibration is intermittent, it should be considered continuous when assessing whether it is acceptable for an operating theatre or precision laboratory. As the multiplying factor is greater than 1, this room would not be suitable for an operating theatre or precision laboratory.

To assess the suitability of the intermittent vibration for other room types, the vibration dose value (VDV) should be used. The VDV can be calculated using the methods in BS 6472.

In this example, the VDV can be calculated using the full integration method in BS 6472 and is found to be  $0.14 \text{ m s}^{-1.75}$ . As this is less than  $0.2 \text{ m s}^{-1.75}$ , the room may be used as a ward.

Using the simpler method in BS 6472 to estimate the VDV (eVDV), the result is:

$eVDV = 1.4 \times \text{frequency-weighted acceleration level} \times t^{0.25}$  (where  $t$  is the total duration of vibration exposure in seconds).

Therefore:

$$VDV = 1.4 \times 0.025 \text{ m s}^{-2} \times (3 \text{ minutes} \times 4 \text{ times per day} \times 60)^{0.25}$$

$$= 0.18 \text{ m s}^{-1.75}$$

In this case, the two methods give the same outcome, even though the results are different.

A proposed layout has a corridor located at midspan. The structural engineer<sup>1</sup> calculates that for people walking at a brisk pace (2.4 steps per second), the floor slab in an adjacent room vibrates with an RMS acceleration of  $0.015 \text{ m s}^{-2}$  at a frequency of 7.2 Hz. People walking at a less hurried pace (1.8 steps per second) within the room itself generate vibration in the floor slab with an RMS acceleration of  $0.009 \text{ m s}^{-2}$ , also at a frequency of 7.2 Hz. What can the room be used for?

\* Step 1 – calculate the frequency-weighted acceleration level:

RMS acceleration  $\times$  frequency weighting of  $W_{eg}$

(BS 6841) at 7.2 Hz

$$= 0.015 \text{ m s}^{-2} \times 1.000$$

$$= 0.015 \text{ m s}^{-2}$$

\* Step 2 – calculate the multiplying factor:

Frequency weighted acceleration level

Base value ( $0.005 \text{ m s}^{-2}$ )

$$= 0.015 \text{ m s}^{-2} / 0.005$$

$$= 3$$

Assuming the vibration is continuous, compare the calculated multiplying factor to the values in 'Continuous vibration' (under 'Vibration'). This room is not suitable for an operating theatre or a ward. It is suitable for use as a general laboratory, treatment area or consulting room.

**Vibration**

# Glossary

4298

4297

**Absorption area:** the surface area of material (in m<sup>2</sup>) multiplied by its absorption coefficient.

**Absorption coefficient:** a measure of the proportion of sound not reflected when striking a surface.

**Airborne sound insulation:** the reduction of sound that is in the air on passing through a building element.

**ANC:** Association of Noise Consultants.

**Attenuator:** device that reduces noise, particularly plant noise and crosstalk – often colloquially (and incorrectly) known as a silencer.

**Audiometric facilities:** rooms used for hearing tests and associated activities.

**Bathroom pod:** a pre-fabricated bathroom.

**Background noise level ( $L_{A90}$ ):** the A-weighted noise level exceeded for 90% of the measurement period. Commonly regarded as the background noise level.

**Background noise level ( $L_{90}$ ):** the linear (not A-weighted) noise level exceeded for 90% of the measurement period. Used as the parameter for measuring service-noise NR levels.

**Competent Person:** someone with appropriate training, qualifications, experience and skill. The person will normally have a diploma or degree in acoustics or a related subject.

**Crosstalk:** noise transfer between rooms, often via ventilation ductwork.

**dB(A):** a single-figure rating to a sound, which represents the human-ear frequency response.

**Decibel (dB):** the unit used for many acoustic qualities to indicate the level with respect to a reference level. For sound pressure, the reference value is normally 20 Pa.

**Equivalent continuous sound pressure level ( $L_{Aeq}$ ):** commonly regarded as the A-weighted “average” noise level over a period of time.

**Equivalent continuous sound pressure level ( $L_{eq}$ ):** the linear (not A-weighted) equivalent continuous sound-pressure level.

**Frequency (Hz):** the number of sound waves to pass a point in one second.

**Frequency-weighted acceleration:** the acceleration multiplied by a specified weighting value.

**Impact sound insulation:** the reduction of sound created by impacts (for example footfalls) on floor slabs over a room.

**IPS panels:** integrated plumbing systems – pre-plumbed and pre-fabricated panels often used for toilets, hand-wash basins, showers etc.

$L_{Amax,t}$ : the highest A-weighted sound-pressure level measured during a given period.

**Mechanical-service noise:** noise generated by mechanical and electrical services.

**Noise intrusion:** noise from external noise sources.

**Noise rating (NR) curves:** a set of curves based on the sensitivity of the human ear. Used to give a single figure for noise levels at a range of frequencies. In this document, NR is intended to be defined between 63 Hz and 4 kHz.

**Octave bands:** a convenient division of the frequency scale, identified by their centre frequency. Typically 63, 125, 250, 500, 1000, 2000, 4000, 8000 Hz.

**Reverberation time:** the time that is taken for sound in a space to decrease by 60 dB. A high reverberation time means the room is echoic. A low reverberation time means the room is acoustically dead.

**RMS:** root mean square.

**Snoezelen room:** a room used to stimulate the various senses as desired.

**Speech intelligibility:** how easily speech can be understood.

**Speech transmission index (STI):** a measure of how intelligible speech is.

**UKAS:** the United Kingdom Accreditation Service.

**Vibration dose value (VDV):** a value that reflects the exposure to vibration over time.

**Warble tones:** sounds used in audiometric testing, normally played over loudspeakers in paediatric test rooms.

**Weighted sound level difference ( $D_w$ ):** unit for rating airborne sound insulation on site (see BS EN ISO 140-4).

**Weighted sound reduction index ( $R_w$ ):** unit for rating airborne sound insulation in a laboratory (see BS EN ISO 140-3).

**Weighted standardised level difference ( $D_{nT,w}$ ):** unit for rating airborne sound insulation on site (see BS EN ISO 140-4).

**Weighted standardised impact sound pressure level ( $L'_{nT,w}$ ):** unit for rating impact airborne sound insulation on site (see BS EN ISO 140-7).

Association of Noise Consultants (ANC)  
United Kingdom Accreditation Service (UKAS)