

HEALTH TECHNICAL MEMORANDUM 06-03

Electrical safety guidance for high voltage systems

2006

STATUS IN WALES

APPLIES

This document should be read in conjunction with ...

It shares a number of model forms with *HTM 06-02: Electrical safety guidance for low voltage systems*. When completing the forms Health Boards and Trusts should consider ways of clearly distinguishing between Low Voltage and High Voltage forms particularly when the two systems are present on the same site.

It replaced
HTM 2021 - Electrical safety code for high voltage systems
(Encode HV), 1993



GIG
CYMRU
NHS
WALES

Partneriaeth
Cydwasaethau
Gwasanaethau Cyfleusterau
Shared Services
Partnership
Facilities Services

For queries on the status of this document contact
info@whe.wales.nhs.uk or telephone 029 2031 5512

Status Note amended May 2021

Electrical services

Health Technical Memorandum

06-03: Electrical safety guidance for high voltage systems

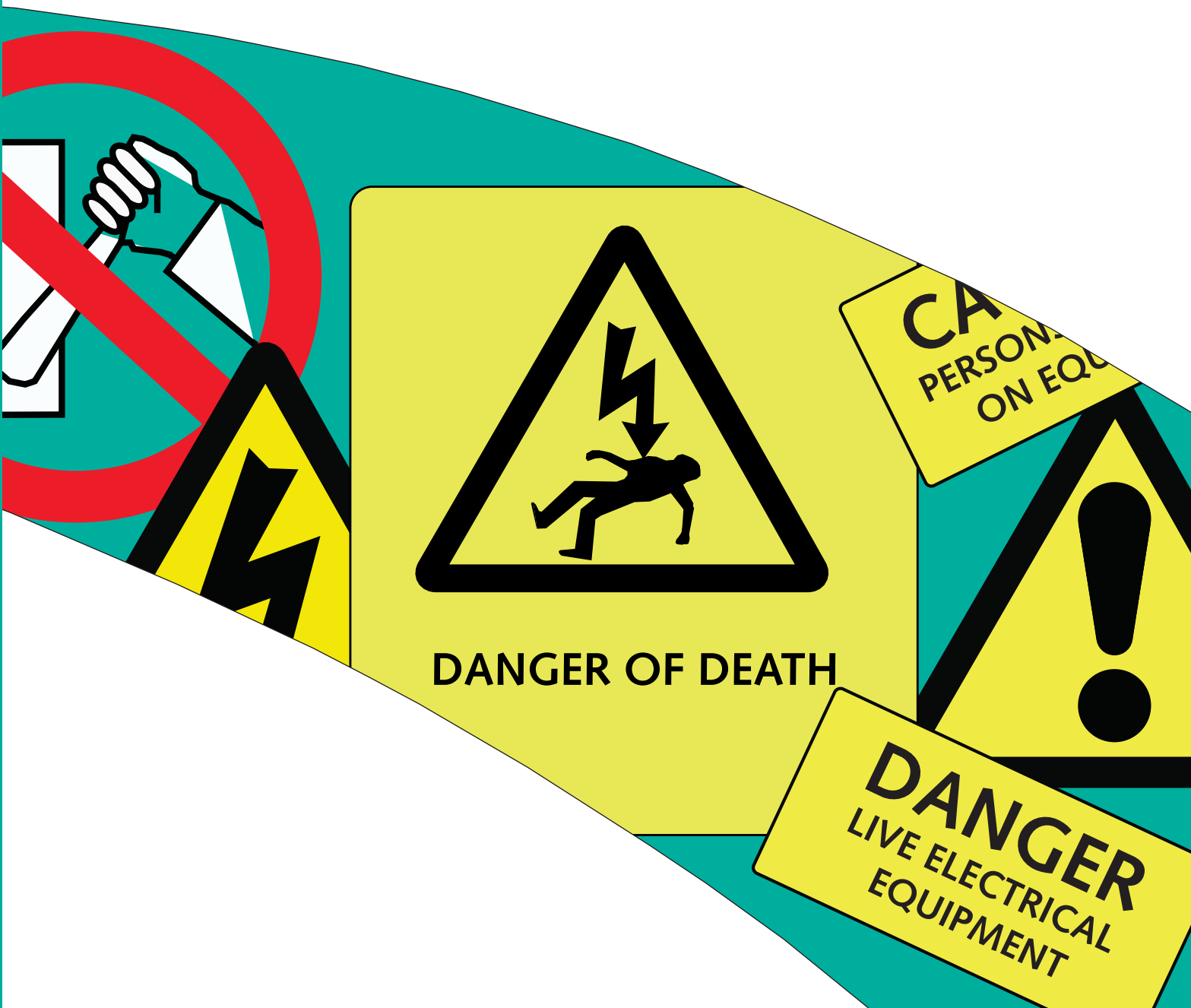

Policy	Estates	
HR / Workforce	Performance	
Management	IM & T	
Planning	Finance	
Clinical	Partnership Working	
Document Purpose	Best Practice Guidance	
ROCR Ref:	Gateway Ref:	7181
Title	HTM 06-03 Electrical Safety Guidance for high voltage systems	
Author	DH Estates and Facilities Division	
Publication Date	October 2006	
Target Audience	PCT CEs, NHS Trust CEs, Care Trust CEs, Foundation Trust CEs , Medical Directors, Directors of Nursing, PCT PEC Chairs, NHS Trust Board Chairs, Special HA CEs	
Circulation List	Department of Health libraries, House of Commons library, Strategic Health Authority, UK Health Departments, Directors of Estates and facilities	
Description	This document covers safe systems of work and safety procedures for operation and management of high voltage (11Kv) electrical installations in healthcare premises. It is supported by safety control and record documents and a concise safety handbook for issue to all authorised persons (HV) engaged on the HV electrical systems.	
Cross Ref	HTM 06-01 and HTM 06-02	
Superseded Docs	HTM 2021 Health Guidance Note "High Voltage Safety Training"	
Action Required	n/a	
Timing	n/a	
Contact Details	Chris Holme, Principal Engineer Department of Health Finance and Investment Directorate Estates and Facilities Division Quarry House Leeds LS2 7UE Chris.holme@dh.gsi.gov.uk	
For Recipient's Use		

Electrical services

Health Technical Memorandum

**06-03: Electrical safety guidance for high
voltage systems**



Published by TSO (The Stationery Office) and available from:

Online

www.tsoshop.co.uk

Mail, Telephone, Fax & E-mail

TSO

PO Box 29, Norwich NR3 1GN

Telephone orders/General enquiries 0870 600 5522

Fax orders 0870 600 5533

E-mail customer.services@tso.co.uk

Textphone 0870 240 3701

TSO Shops

123 Kingsway, London WC2B 6PQ

020 7242 6393 Fax 020 7242 6394

68–69 Bull Street, Birmingham B4 6AD

0121 236 9696 Fax 0121 236 9699

9–21 Princess Street, Manchester M60 8AS

0161 834 7201 Fax 0161 833 0634

16 Arthur Street, Belfast BT1 4GD

028 9023 8451 Fax 028 9023 5401

18–19 High Street, Cardiff CF10 1PT

029 2039 5548 Fax 029 2038 4347

71 Lothian Road, Edinburgh EH3 9AZ

0870 606 5566 Fax 0870 606 5588

TSO Accredited Agents

(see Yellow Pages)

and through good booksellers

© Crown copyright 2006

Published with the permission of the Estates and Facilities Division of the Department of Health, on behalf of the Controller of Her Majesty's Stationery Office.

This document/publication is not covered by the HMSO Click-Use Licences for core or added-value material.

If you wish to re-use this material, please send your application to:

Copyright applications

The Copyright Unit

OPSI

St Clements House

2–16 Colegate

Norwich NR3 1BQ

ISBN 0-11-322758-2

978-0-11-322758-7

First published 2006

Printed in the United Kingdom for The Stationery Office

The paper used in the printing of this document (Revive Silk) is 75% made from 100% de-inked post-consumer waste, the remaining 25% being mill broke and virgin fibres. Recycled papers used in its production are a combination of Totally Chlorine Free (TCF) and Elemental Chlorine Free (ECF). It is recyclable and biodegradable and is an NAPM and Eugropa approved recycled grade.



Preface

About Health Technical Memoranda

Engineering Health Technical Memoranda (HTMs) give comprehensive advice and guidance on the design, installation and operation of specialised building and engineering technology used in the delivery of healthcare.

The focus of HTM guidance remains on healthcare-specific elements of standards, policies and up-to-date established best practice. They are applicable to new and existing sites, and are for use at various stages during the whole building lifecycle:

Figure 1 Healthcare building life-cycle

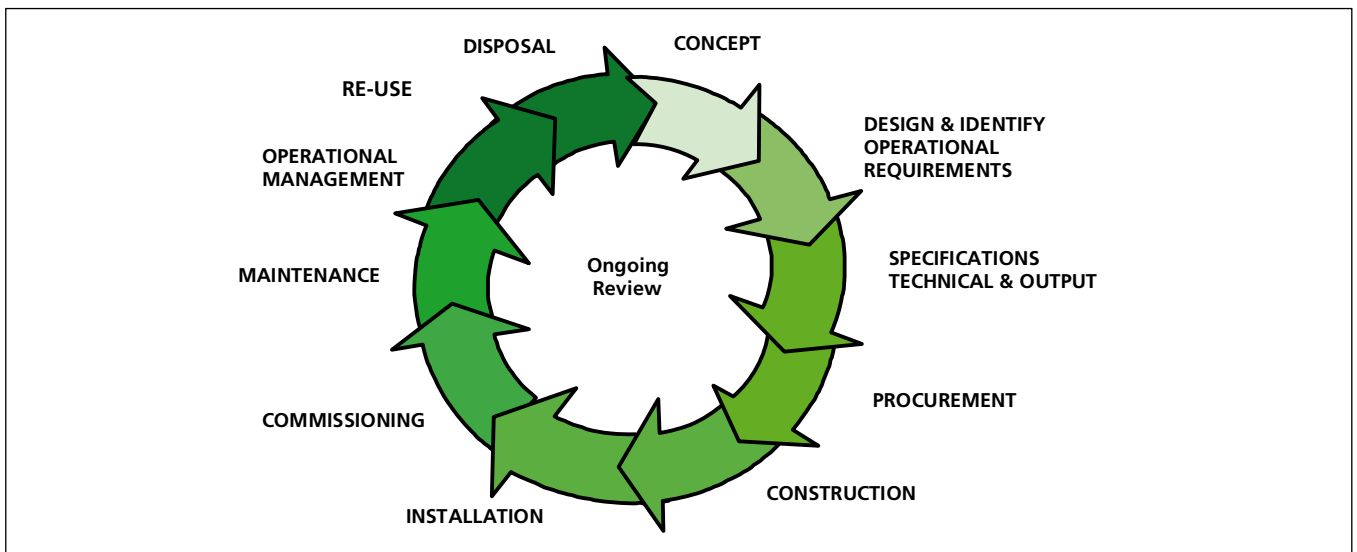

Healthcare providers have a duty of care to ensure that appropriate engineering governance arrangements are in place and are managed effectively. The Engineering Health Technical Memorandum series provides best practice engineering standards and policy to enable management of this duty of care.

It is not the intention within this suite of documents to unnecessarily repeat international or European standards, industry standards or UK Government legislation. Where appropriate, these will be referenced.

Healthcare-specific technical engineering guidance is a vital tool in the safe and efficient operation of healthcare facilities. Health Technical Memorandum guidance is the

main source of specific healthcare-related guidance for estates and facilities professionals.

The core suite of nine subject areas provides access to guidance which:

- is more streamlined and accessible;
- encapsulates the latest standards and best practice in healthcare engineering;
- provides a structured reference for healthcare engineering.

Structure of the Health Technical Memorandum suite

The series of engineering-specific guidance contains a suite of nine core subjects:

- Health Technical Memorandum 00
Policies and principles (applicable to all Health Technical Memoranda in this series)
- Health Technical Memorandum 01
Decontamination
- Health Technical Memorandum 02
Medical gases

Electrical services – HTM 06-03 Electrical safety guidance for high voltage systems

Health Technical Memorandum 03
Heating and ventilation systems

Health Technical Memorandum 04
Water systems

Health Technical Memorandum 05
Fire safety

Health Technical Memorandum 06
Electrical services

Health Technical Memorandum 07
Environment and sustainability

Health Technical Memorandum 08
Specialist services

Some subject areas may be further developed into topics shown as -01, -02 etc and further referenced into Parts A, B etc.

Example: Health Technical Memorandum 06-02 Part A will represent:

Electrical Services – Electrical safety guidance for low voltage systems

In a similar way Health Technical Memorandum 07-02 will simply represent:

Environment and Sustainability – EnCO₂de.

All Health Technical Memoranda are supported by the initial document Health Technical Memorandum 00 which embraces the management and operational policies from previous documents and explores risk management issues.

Some variation in style and structure is reflected by the topic and approach of the different review working groups.

DH Estates and Facilities Division wishes to acknowledge the contribution made by professional bodies, engineering consultants, healthcare specialists and NHS staff who have contributed to the review.

Figure 2 Engineering guidance

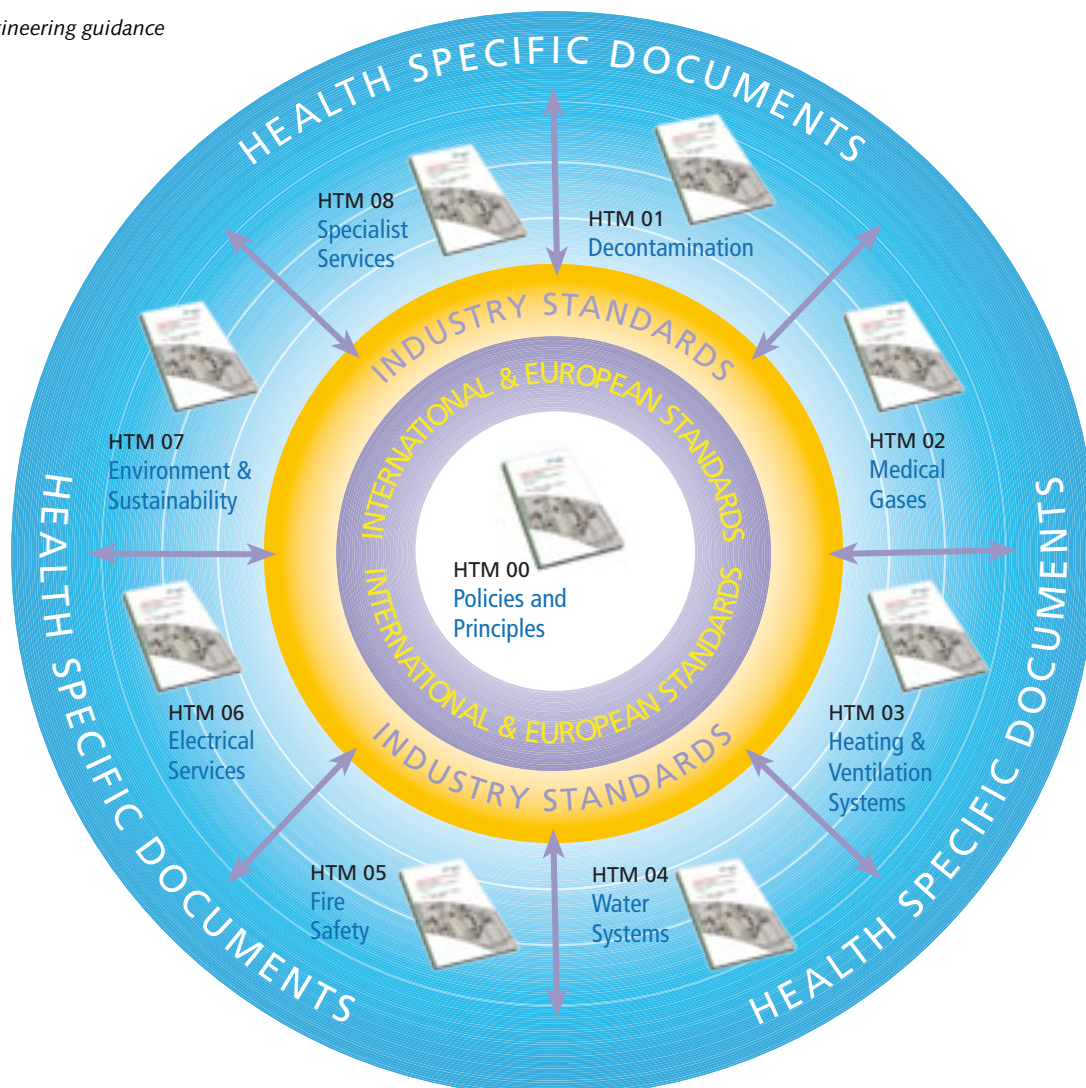

Executive summary

Status

Health Technical Memorandum 06-03 replaces and supersedes all previous versions of Health Technical Memorandum 2021 – ‘Safety code for high voltage systems’.

General

This Health Technical Memorandum gives operational guidance on electrical safety requirements for high voltage systems in healthcare premises.

Aim of this guidance

Guidance is intended to assist in meeting the requirements of the Electricity at Work Regulations 1989, which detail the precautions to be taken against risk of death or personal injury from electricity in work activities.

Who should read this guidance?

This document will be of interest and practical help to those involved in the design, purchase and construction of electrical systems and equipment.

Structure

Health Technical Memorandum 06-03 consists of this main guidance document and an “Authorised Person’s logbook for high voltage systems” (published separately).

This main guidance document provides information and statutory guidance for those responsible for meeting the requirements of the Electricity at Work Regulations 1989.

The management policy section outlines the overall responsibility of managers of healthcare premises and details their legal and mandatory obligations in setting up and operating reliable high voltage electrical safety procedures.

The “Authorised Person’s logbook for high voltage systems” should be issued to each Authorised Person (HV). The booklet contains extracts from this document.

Acknowledgements

Brian Godfrey	Health Estates, Northern Ireland
Chris Holme	Department of Health
John Bicknell	Trent Architecture and Design, Sheffield
Nigel Porter	Welsh Health Estates
Peter DesForges	Develop, Cramlington, Northumberland

Contents

Preface		
Executive summary		
Acknowledgements		
Chapter 1	Scope	1
	General	
	Purpose	
	Procedures	
	Standards	
	Duties	
	Security of information	
	Application of this guidance	
	Other safety guidance, related documents and procedures	
	Information and instruction	
	Issue of this safety guidance (HV)	
	Variation of safety guidance (HV)	
	Objections	
	Definition of “should”	
	Definition of “reasonably practicable”	
	Associated regulations and documents	
	Statutory	
	Guidance	
Chapter 2	Definitions	5
	Personnel	
	Designated Person	
	Duty Holder	
	Management	
	Authorising Engineer (HV)	
	Authorised Person (HV)	
	Duty Authorised Person (HV)	
	Competent Person (HV)	
	Accompanying Safety Person (HV)	
	Safety documents	
	Permit-to-work	
	Sanction-for-test	
	Limitation-of-access	
	Safety signs	
	Caution sign	
	Danger sign	
	Warning sign	
	Voltage range	
	General definitions	
Chapter 3	Management policy	9
Chapter 4	Appointment, roles and duties of personnel	11
	General	

	Roles and duties of the Designated Person (HV)	
	Role and duties of the Authorising Engineer (HV)	
	Roles and duties of the Authorised Persons (HV)	
	Role and duties of the Competent Person (HV)	
	Role and duties of the Accompanying Safety Person (HV)	
	Appointment of an Authorising Engineer (HV)	
	Appointment and re-appointment of an Authorised Person (HV)	
	Review of an Authorised Person (HV)'s appointment	
	Refresher training for an Authorised Person (HV)	
	Suspension of an Authorised Person (HV)'s duties	
	Appointment of a Competent Person (HV)	
	Appointment of a Competent Person (HV) via a certificate of appointment	
	Suspension of a Competent Person (HV)'s duties	
	Contractor's Competent Persons (HV)	
Chapter 5	Demarcation of responsibilities between the management and others	18
	General	
	Where the management has control of the danger for part of another organisation's system or installation	
	Where the management does not have control of the danger for a system or installation	
	Where contractors are to undertake installation work on an existing system or installation for which the management has control of the danger	
	For new work before the system or installation is accepted from the contractor	
	Where a distribution network operator (DNO) appoints a management Authorised Person to operate DNO equipment	
Chapter 6	General precautions	20
	Security and admittance to substations	
	Operational keys	
	Key-plate system	
	Key cabinets	
	Lockable document cabinet	
	Authorised Person (HV)'s key-box	
	Mimic diagram	
	Safety locks	
	Safety key-boxes	
	Operation of high voltage switchgear	
	Action in an emergency	
	High voltage enclosures	
	Dangerous occurrences	
	Operational restrictions	
	Circuit main earths	
	Earthing leads and connections	
	Procedure for the use of earthing leads	
	Earthing equipment	
	Location of underground cables	
	Fire protection equipment	
	Automatic control	
	Portable extinguishers	
	Coolant and arc-extinguishing media	
	Equipment containing sulphur hexafluoride (SF ₆)	
	Vessels containing oil or flammable liquids	
	Access to, and work in, underground chambers, vessels and confined spaces	
	Protective equipment	
	Test equipment	

Chapter 7	Safety precautions and procedures for work on high voltage equipment	27
	General	
	Identification and spiking of HV cables	
	Precaution prior to live voltage and phasing checks	
	Testing at high voltage	
	High voltage test enclosures	
	Withdrawable equipment	
	Work on remotely and automatically controlled electrical equipment	
	Electrical equipment which can be made live from a DNO's supply system	
	Work on busbar spouts of multi-panel switchboards	
	Work on feeder spouts, voltage transformer spouts or single-panel busbar spouts	
	Work on distribution transformers	
	Work on generators	
	Issuing of a permit-to-work or sanction-for-test	
	Summary	
Chapter 8	Operating records	33
	General	
	Site logbook	
	Substation logbook	
	Authorised Person (HV)'s logbook	
	Operational procedure manual	
	Operating and maintenance manuals	
	Maintenance records	
	Isolation and earthing diagram	
	Implementing the isolation and earthing diagram	
	Completion of the work or test	
	Safety programmes	
	General	
	Contents of safety programmes	
	Implementing safety programmes	
	Completion of safety programmes	
	Permits-to-work	
	General	
	Issue and acceptance of permits-to-work	
	Cancellation of the permit-to-work	
	Sanctions-for-test	
	General	
	Issue and acceptance of sanctions-for-test	
	Cancellation of the sanction-for-test	
	Limitation-of-access	
	General	
	Issue and acceptance of limitations-of-access	
	Cancellation of a limitation-of-access	
Chapter 9	Display of permanent posters and safety signs	42
	Display of posters	
	Design specification	
	Display of permanent safety signs	
	Display of temporary safety signs	
Chapter 10	Protective, test and earthing equipment	45
	General	
	Protective equipment	
	Protective equipment covered by a British Standard	
	Protective equipment not covered by a British Standard	

	Voltage test indicators	
	High voltage test equipment	
	Cable-locating devices	
	Earthing equipment	
	Substation earthing	
	Recommendations for the inspection, test and recalibration of protective, test equipment	
	Fire extinguisher installation and equipment	
Appendix 1	Safety documentation (model forms)	48
	Model form numbers	
	Isolation and earthing diagram	
	Safety programme	
	Permit-to-work	
	Limitation-of-access	
	Sanction-for-test	
	Logbook	
Appendix 2	Model procedures and letters	61
	Appointment procedure for an Authorising Engineer (HV)	
	Model letter for appointing an Authorised Engineer (HV)	
	Model letter for accepting an appointment as an Authorising Engineer (HV)	
	Appointment procedure for an Authorised Person (HV)	
	Part 1: Nomination procedure	
	Part 2: Personal details	
	Part 3: Certification of satisfactory training and familiarisation	
	Model letter for appointing an Authorised Person (HV) by management	
	Model letter for accepting an appointment as an Authorised Person (HV)	
	Certificate of appointment – Authorised Person (HV)	
	Part 1: Appointment record	
	Part 2: HV training record	
	Part 3: First-aid training record	
	Appointment procedure for a Competent Person (HV)	
	Part 1: Nomination procedure	
	Part 2: Personal details	
	Part 3: Approval and scope of appointment	
	Model letter for appointing or re-appointing a Competent Person	
	Model letter for accepting an appointment or re-appointment as Competent Person	
	Certificate of appointment as a Competent Person	
	Appointment record	
Appendix 3	Audit of safe system of work and safety procedures	77
	General	
	Validation audits by the Designated Person	
	Compliance audits by Authorising Engineers	
	Audit programme and progress reports	
	Compliance audits	
	Authorised person and documentation audit	
	Safety equipment	
	Mimic diagram and system keys	
	Substations and other installations	
	Non-compliances	
	Audit report	
	Action plan	
	Short notice compliance audits by Authorising Engineers	
	Compliance monitoring by Authorised Persons	
	Auditing aids	

	Authorising Engineer's audit checklist	
	Authorised Persons	
	Audit trail	
	Documentation	
	Safety equipment	
	Mimic diagram and system keys	
	Substations	
	Substation security	
	Substation structure	
	Substation posters and labels	
	HV switchgear	
	Fire precautions	
Appendix 4	Mimic diagram and key locker	82
	Mimic diagram	
	Keys	
Appendix 5	The Electricity Safety, Quality and Continuity Regulations 2002	83
Appendix 6	Typical single line diagram and switchgear and transformer schedules for a high voltage system	84
	Grading charts	
Appendix 7	Standard symbols for isolation and earthing diagram	88
	Switchgear	
	Operation	
	Switches/fused units	
	Circuit breakers	
Appendix 8	Poster	90
Appendix 9	Qualifications and training requirements	91
	Qualifications of an Authorising Engineer	
	Authorising Engineer (LV) initial training	
	Qualifications of Authorised Persons (LV)	
	Authorised Person (HV) initial training	
	Refresher training	
	Familiarisation training	
	On-site training	
	Approved courses	
	Initial training course for an Authorising Engineer (HV)	
	Training course profile for Authorised Person (HV) initial training	
	Training course profile for Authorised Person refresher training	
	Emergency first-aid training and equipment	
	Contractors' staff	
References		96
	Acts and regulations	
	British Standards	
	Department of Health publications	
	Other publications	

1 Scope

General

- 1.1 Guidance in this Health Technical Memorandum applies to all healthcare facilities containing a high voltage system.
- 1.2 Guidance is intended to assist Duty Holders (see [Chapter 2](#) for definitions) to meet the requirements of the Electricity at Work Regulations 1989 (“the Regulations”), which are made under the Health and Safety at Work etc Act 1974 (HSW Act 1974). It is not an authoritative interpretation of the regulations or other laws. Only the courts can make such interpretation.
- 1.3 Inadequate control and/or improper use of electricity is a danger to life and property. Owners, occupiers, general managers/chief executives and those responsible for electrical services as “Duty Holders” are accountable for ensuring control; they are also responsible for the safe management, design, installation, operation and maintenance of the electrical systems.
- 1.4 As an employer, the management of a healthcare facility has a legal responsibility to ensure that relevant regulations are complied with. Statutory instruments referred to within this document should be deemed to include any revisions or amendments which have occurred since the date of the original statute.
- 1.5 The reliance on electrical supplies has increased to a point where they are essential for the operation of any organisation. In hospitals, there has been a substantial increase in the use of modern technologies – diagnostic equipment, intensive care, computer systems and bed-head services to name a few. The loss of supplies to these services would be unacceptable, and most hospitals would be unable to function without electrical supplies. Health Technical Memorandum 06-01 – ‘Electrical services supply and distribution’ addresses the security of supply and emergency-generation issues; however, this would be of little use if the distribution circuits were compromised. This

document not only has procedural guidance on the correct isolation of electrical equipment but also includes guidance on ensuring the security of supplies.

- 1.6 The roles of the Authorising Engineer (HV) and Authorised Person (HV) are twofold: first, they should ensure that the electrical systems and equipment are fit for use; second, they should ensure the safety of personnel who are using, or who are near, such equipment.
- 1.7 To ensure systems are fit for use, the Authorising Engineer (HV) and the Authorised Person (HV) should be consulted before major alterations or the procurement of major plant (which could adversely affect the existing installation) are made.

Purpose

- 1.8 The provision of effective procedures and their formalising into written instructions is essential for ensuring a safe system of working where this involves work on conductors or equipment of high voltage systems. This document makes recommendations for the allocation of duties to personnel and the manner in which these duties should be performed.

Procedures

- 1.9 High voltage systems associated with healthcare and social services premises vary considerably in size and complexity. The procedures advocated in this document therefore cannot cover every circumstance and consequently may, in specific instances, need to be supplemented by local written procedures. These local arrangements should only be considered when, in the opinion of the Authorising Engineer (HV), the guidance given in this document is inadequate for the particular circumstances. Any such supplementary procedures must therefore maintain the same standards of electrical safety outlined in this guidance.

- 1.10 Because of the specialist nature of the risks, it is important that a carefully prepared procedure exists for dealing with the routine servicing of high voltage installations and with any emergencies that arise.
- 1.11 The consequences – in terms of patient safety and well-being – of undertaking electrical maintenance or switching operations must be fully considered following appropriate consultation with medical and administrative staff.

Standards

- 1.12 This document is primarily concerned with the safe operation and maintenance of high voltage equipment, but it is equally important that the high voltage equipment installed:
- complies with the appropriate British Standards and, where applicable, international and/or European Standards;
 - has been satisfactorily tested.
- 1.13 It is also important that operating and maintenance manuals (including “as-installed” drawings and switchgear and transformer (S&T) schedules) for the high voltage system must be available to those involved in its operation and servicing. In order to maintain their value, these documents must be regularly updated to include details of all modifications and extensions to plant and equipment as and when they occur.
- 1.14 Switchgear etc should be standardised as far as practicable to reduce variety and facilitate easier servicing. Where manufacturers produce special attachments to facilitate servicing and testing, these should be bought with the electrical equipment and placed with other safety equipment.

Duties

- 1.15 There is a legal obligation on all persons who may be concerned with the operation of, or who work on, the electrical equipment and systems at the managed premises to conduct their work so as to prevent danger or injury to themselves and/or others. They should also be thoroughly conversant with all regulations governing the work that they may have to undertake.

Security of information

- 1.16 The Electricity at Work Regulations 1989 highlight a need for the efficient recording of information

which, in the event of any proceedings legal or otherwise arising from any contravention of the regulations, may be used to form the basis of the Duty Holder’s main defence. Consequently, management should consider its policy for the retention of information and contemplate how it will maintain, if at all, back-up copies of documents.

Application of this guidance

- 1.17 The safety guidance (HV) as detailed in this document should be applied to:
- high voltage systems up to and including 36 kV;
 - the high voltage switchgear cables up to the first isolation point on the low voltage system;
 - associated electrical equipment under the ownership or control of the management under whose authority they have been issued.
- 1.18 Where operation of low voltage switchgear is associated with high voltage work, the requirement for safety documents as indicated in this Health Technical Memorandum does not apply, and reference should be made to Health Technical Memorandum 06-02 – ‘Electrical safety guidance for low voltage systems’.
- 1.19 This guidance should be considered as representing best practice for all persons (whether or not directly employed by the management) working on, working near, testing or operating electrical equipment and systems for which management is in control of electrical danger, unless the Authorising Engineer (HV) has deemed in writing that other guidance is equal and equivalent.
- 1.20 This guidance is designed to provide a safe framework within which work or testing can be carried out with safety on permanently connected electrical equipment (equipment which has been isolated via a switch or disconnect is considered to be permanently connected).
- 1.21 In case of an apparent conflict between this guidance and a statutory requirement, the latter should be followed, and the Authorising Engineer (HV) is to advise the Designated Person.
- 1.22 If it is necessary to depart from any requirement of this guidance, the Authorising Engineer (HV) is to agree such departure in writing with the Designated Person before it is implemented.

- 1.23 Where control of electrical danger is divided between management and others, **Chapter 4** of this guidance should be followed.
- 1.24 Further advice on the application of this guidance can be obtained from the Authorising Engineer (HV).

Other safety guidance, related documents and procedures

- 1.25 Where management employees are required to work near electrical systems and associated electrical equipment not owned or controlled by the management, this document (HV) and related procedures should be used as a guide to safe working practice.

Information and instruction

- 1.26 Arrangements should be made by management to ensure:
- that all employees concerned are adequately informed and instructed as to the systems and electrical equipment which are affected by a particular operation or work (whether or not they are owned or operated by the management) and which legal requirements, safety guidance, related documents and procedures should apply;
 - so far as is reasonably practicable, that other persons who are not employees, but who may be exposed to danger by the operations or work, also receive adequate information and instruction.

Issue of this safety guidance (HV)

- 1.27 A copy of this guidance and, as appropriate, related documents and procedures should be issued to certain management employees and other persons as determined by the Authorising Engineer (HV). Such employees and other persons should sign a receipt for a copy of this guidance, related documents and procedures (plus any amendments), keep them in good condition and have them available for reference as necessary when work is being carried out under this guidance.

Variation of safety guidance (HV)

- 1.28 In exceptional or special circumstances, this guidance may be varied to such an extent as is necessary and approved by the Authorising Engineer (HV). Such variation should always be in

writing and should ensure that safety requirements are satisfied in some other way.

Objections

- 1.29 When any person receives instructions regarding the operation of, or work on, the high voltage system and associated electrical equipment at the managed premises, they should report any objections (on safety grounds) to the carrying out of such instructions to the persons issuing them, who should then have the matter investigated and, if necessary, referred to a more senior level for a decision before proceeding.

Definition of “should”

- 1.30 Where “should” is used in this guidance with no qualification, this indicates a recommendation or that which is advised but not required.

Definition of “reasonably practicable”

- 1.31 Where a statement is qualified by the words “reasonably practicable”, a slightly less strict standard is imposed. It means that an assessment should be made considering, on the one hand, the magnitude of the risks of a particular work activity or environment and, on the other hand, the cost in terms of the physical difficulty, time, trouble and expense which would be involved in taking steps to eliminate or minimise those risks. The greater the degree of risk, the less weight that can be given to the cost of measures needed to prevent that risk.

Associated regulations and documents

Statutory

- Approved Code of Practice for Management of Health and Safety at Work Regulations 1999.
- BS 7671:2001. Requirements for electrical installations. IEE Wiring Regulations. Sixteenth edition.
- Construction (Design and Management) Regulations 2002.
- Electricity at Work Regulations 1989.
- Electricity Safety, Quality and Continuity Regulations 2002.
- Health and Safety (Safety Signs and Signals) Regulations 1996.
- Health and Safety at Work etc Act 1974.

- Health and Safety (First-aid) Regulations 1981.
- Management of Health and Safety at Work Regulations 1999.
- Manual Handling Operations Regulations 1992.
- Personal Protective Equipment Regulations 2002.
- Provision and Use of Work Equipment Regulations 1998.
- Reporting of Injuries, Diseases and Dangerous Occurrences Regulations 1995.
- Workplace (Health, Safety and Welfare) Regulations 1992.

Guidance

- The Department of Health's:
 - Health Technical Memorandum 00 – 'Policies and principles'.
 - Health Technical Memorandum 06-01 – 'Electrical services supply and distribution'.
 - Health Technical Memorandum 06-02 – 'Electrical safety guidance for low voltage systems'.
- The Institution of Electrical Engineers':
 - 'Code of practice for in-service inspection and testing of electrical equipment'.
 - 'Guidance Note 3 – Inspection and testing'.
- The Health & Safety Executive's:
 - 'Electricity at work: safe working practices HSG85'.
 - 'Keeping electrical switchgear safe HSG230'.
 - 'Memorandum of guidance on the Electricity at Work Regulations 1989 HSR25'.

2 Definitions

- 2.1 With regard to this safety guidance (HV), the following definitions apply.

Personnel

Designated Person

- 2.2 The Designated Person is an individual appointed by a healthcare organisation (a board member or a person with responsibilities to the board) who has overall authority and responsibility for the high voltage electricity system within the premises and who has a duty under the Health and Safety at Work etc Act 1974 to prepare and issue a general policy statement on health and safety at work, including the organisation and arrangements for carrying out that policy. This person should not be the Authorising Engineer (HV).

Duty Holder

- 2.3 The Duty Holder is a person on whom the Electricity at Work Regulations 1989 impose a duty in connection with safety.

Management

- 2.4 Management is defined as the owner, occupier, employer, general manager, chief executive or other person in a healthcare organisation, or their appointed responsible contractor, who is accountable for the premises and who is responsible for issuing or implementing a general policy statement under the Health and Safety at Work etc Act 1974.

Authorising Engineer (HV)

- 2.5 An Authorising Engineer (HV) is appointed in writing by the Designated Person to take responsibility for the effective management of this safety guidance (HV). The person appointed should possess the necessary degree of independence from local management to take action within this guidance.

Authorised Person (HV)

- 2.6 An Authorised Person (HV) is appointed in writing by the management on the recommendation of the Authorising Engineer (HV) in accordance with this safety guidance (HV) and is responsible for the implementation and operation of this guidance with regard to work on, or the testing of, defined electrical equipment.

Duty Authorised Person (HV)

- 2.7 An Authorised Person (HV) who has current responsibility for a system or installation as recorded in the site logbook, whose name is displayed at the mimic diagram and who personally holds or carries the Authorised Person's (HV) key.

Competent Person (HV)

- 2.8 A Competent Person (HV) is approved and appointed in writing by the Duty Authorised Person (HV) for defined work, possessing the necessary technical knowledge, skill and experience relevant to the nature of the work to be undertaken, who is able to prevent danger or, where appropriate, injury and who is able to accept a safety document from the Duty Authorised Person (HV).

Accompanying Safety Person (HV)

- 2.9 An Accompanying Safety Person is a person not involved in the work or test who has received emergency first-aid for electric shock and who has adequate knowledge, experience and the ability to avoid danger, keep watch, prevent interruption, apply first-aid and summon help. The person should be familiar with the system or installation being worked on or tested and is to have been instructed on the action to be taken to safely rescue a person in the event of an accident.

Safety documents

Permit-to-work

2.10 A written authority issued by the Duty Authorised Person for work to be undertaken on electrical equipment.

Sanction-for-test

2.11 A written authority issued by the Duty Authorised Person for testing to be undertaken on electrical equipment.

Limitation-of-access

2.12 A written authority issued by the Duty Authorised Person for specified tasks to be undertaken in an area or location which is under the control of the Authorised Persons for electrical safety reasons, and for which a permit-to-work or sanction-for-test are not appropriate.

Safety signs

Caution sign

2.13 This is a temporary, non-metallic sign bearing the words “caution – persons working on equipment” and “do not touch” which should be used at a point-of-isolation.

Danger sign

2.14 This sign is a temporary, non-metallic sign bearing the words “danger live equipment” and “do not touch” which should be used where there is adjacent live equipment at the place of work.

Warning sign

2.15 This sign is a permanent, non-metallic sign bearing the words “danger of death”, or may be a combined warning sign and notice. The relevant voltage, if in excess of low voltage, should be displayed below the words “danger of death” in black letters and in the same letter size.

Voltage range

2.16 The following ranges of voltage are defined as follows:

- a. **extra low voltage:** a potential not exceeding 50 V ac or 120 V ripple-free dc whether between conductors or to earth;

- b. **low voltage (LV):** a potential not exceeding 1000 V ac or 1500 V dc between conductors, or 600 V ac or 900 V dc between a conductor and earth;
- c. **high voltage (HV):** a potential normally exceeding low voltage.

General definitions

Additional earth: earthing equipment of an approved type applied after the issue of a safety document (for example an earth applied at a point-of-work).

Audit: the structured process of collecting independent information on the efficiency, effectiveness and reliability of the safe system of work, and drawing up plans for corrective action (see [Appendix 3](#)). (“Independent” does not necessarily mean external to the organisation.)

Authorised Person’s (HV) key: a key that controls access to the key cabinet.

Authorised Person’s (HV) key-box: a single locked box that is used for the control of the Authorised Person’s (HV) key.

Authorised Person’s (HV) logbook: A personal logbook to record all switching carried out on the site’s HV system(s) prior to and after becoming an Authorised Person. This logbook will also contain extracts from this guidance.

Circuit main earth: A safety earthing connection of an approved type, secured where practicable by a Safety Lock, applied by an Authorised Person and its position recorded before the issue of a safety document.

Conductor: a conductor of electrical energy.

Danger: risk of injury or death.

Dangerous condition: a condition that is likely to lead to a dangerous occurrence.

Dangerous occurrence: an incident involving a source of electrical energy which may be dangerous to any person, whether or not an accident has occurred.

Dead: a conductor that is neither “live” nor “charged”.

Department: Department of Health or its appointed agent.

Earthed: connected to the general mass of earth in such a manner as will ensure at all times an immediate discharge of electrical energy without danger.

Electrical equipment: anything used, intended to be used or installed for use in order to generate, provide,

transmit, transform, rectify, convert, conduct, distribute, control, store, measure or use electrical energy.

High voltage enclosure: a location within which a live high voltage conductor is, or can be, exposed without the use of a tool or key.

Injury: death or personal injury from electric shock, electric burn, electrical explosion or arcing, or from fire or explosion initiated by electrical energy, where any such death or injury is associated with the generation, provision, transmission, transformation, rectification, conversion, conduction, distribution, control, measurement or use of electrical energy.

Isolate: disconnect and separate electrical equipment from every source of electrical energy in such a way that this disconnection and separation is secure.

Isolation and earthing diagram: a diagram attached to a permit-to-work or sanction-for-test illustrating the safety measures taken.

Key cabinet: a cabinet for the sole purpose of retaining all keys relative to the site's HV/LV system(s) to which the Duty Authorised Person (HV) has control.

Live: implies connection to a source of electricity.

Live functional testing: the testing of electrical equipment while live which does not involve live working.

Live working: the connection/disconnection of electrical equipment while live.

Lockable document cabinet: a lockable cabinet suitable for storing the electrical safety documents, temporary safety signs, distribution system records etc used in the application of this guidance. This cabinet should not be used to store anything not associated with this guidance.

Mimic diagram: a single line diagram of an electrical distribution system so made that the symbol for each item of switchgear may be adjusted to indicate the "on", "off" or "earthed" positions.

Operational procedure manual: a ring-binder containing information relating to the control and operation of the high voltage system.

Operational restriction: a written safety instruction, issued via the Authorising Engineer (HV), modifying or prohibiting the normal operating procedures associated with a particular make and type of equipment.

Personal supervision: supervision is given by a person having adequate technical knowledge and experience, who is present at all times.

Practice improvement notice: a notice issued by the auditor requiring improvements to be made in the observed working practices. The notice will relate to specific task(s) and will give a target date and/or time by which the improvements must be in place before similar task(s) can continue to be carried out.

Protective equipment: equipment used to protect persons from danger in the working environment. Protective equipment includes items such as special tools, protective clothing, insulating screens, safety harnesses, temporary safety signs etc.

Prove dead: demonstrate with the use of approved test equipment designed for the purpose that no electrical potential liable to cause danger is present.

Risk assessment: the analysis of the risks to health and safety inherent in a system and their significance in a particular context.

Safety key-box: a box having two locks, each of which is to have only one key: one being labelled "Safety key-box – Competent Person (LV)"; and the other "Safety key-box – Authorised Person (LV)". It should be so arranged that both locks must be released before access can be gained to the contents of the box.

Safety locks: a padlock indelibly coloured red, having a single key that differs from all other keys provided for the system or installation, used for securing the means of isolation and to prevent the removal of circuit main earths.

Safety programme: a written programme issued by the Duty Authorised Person, setting out the sequence of operations to be followed before a permit-to-work or a sanction-for-test is issued.

Single line drawing: a single line drawing of the whole site system showing all HV and major LV equipment in its normal state of operation (that is, switched on-off etc).

Site logbook: a book in which all matters relating to the electrical system should be recorded.

Spiking gun: an item of safety equipment used to confirm that a cable is dead.

Sulphur hexafluoride (SF₆): a gas that is used in electrical power equipment. It is colourless, odourless, non-flammable and chemically stable. SF₆ is a very good electrical insulator and can effectively extinguish arcs, which makes high and medium voltage apparatus filled with SF₆ highly popular.

Suspension notice: a notice issued by the auditor requiring specified works in progress to be suspended immediately pending action to ensure that compliance

with the existing safe system of work can be achieved or a modified system introduced. This may follow an auditor's system improvement notice being issued.

Substation: Any premises, or part thereof, which contains equipment for either transforming or converting energy to or from high voltage (other than transforming or converting solely for the operation of switching devices or instruments), or for switching, controlling or regulating energy at high voltage.

Substation logbook: a book held in each substation into which every entry to the room is recorded and the reason; this book is also used to record the Authorised Person's (HV) three-monthly inspections.

System: an electrical system in which all the equipment is, or may be, connected to a common source of electrical energy, including the source and its associated equipment.

3 Management policy

- 3.1 Management and its nominated staff as “Duty Holders” are responsible for the safety of high voltage (HV) electrical systems on their premises. The Electricity at Work Regulations 1989 impose duties on “employers” to comply with these insofar as they relate to matters that are within their control. These duties are in addition to those imposed by the Health and Safety at Work etc Act 1974.
- 3.2 To satisfy these requirements, management should have:
- a clearly defined electrical safety policy and programme for the operation and servicing of their high voltage system(s) and equipment;
 - means by which the policy and programme can be managed, implemented, monitored and reviewed.
- 3.3 In addition to ensuring that all statutory requirements relating to electrical safety are observed, management should have:
- a clearly defined electrical safety policy;
 - a structure, appropriate to the complexity of the work, for implementing the policy – including an outline description of individual responsibilities;
 - procedures for ensuring the effective administration of the policy;
 - a system of monitoring to ensure that the policy is being effectively pursued within the managed premises;
 - a programme of training to ensure the awareness of all staff on the use of electricity and general electrical safety;
 - appropriate training for relevant professional and technical staff;
 - a procedure for dealing with any emergencies that may arise.
- 3.4 Management should formally nominate in writing a Designated Person with responsibility for the high voltage electrical safety policy.
- 3.5 The electrical safety policy should demonstrate the commitment of management to self-regulation and reflect the uniqueness and special needs of the managed premises for which it is written by:
- recognising the importance of the subject;
 - ensuring that responsibilities both legal and managerial are clearly defined and understood throughout the organisation;
 - establishing the arrangements for preventing danger or injury to persons from electrical causes in connection with work activities and ensuring that high standards of electrical safety are reflected in the management, design, installation, operation and maintenance of systems and equipment in respect of premises owned or occupied by them;
 - monitoring and reviewing at regular intervals the effectiveness of the policy and progress concerning its implementation;
 - ensuring that clear and concise written records are kept of all activities involved in the implementation of the policy.
- 3.6 Within each management structure, an electrical engineer should be formally appointed as an Authorising Engineer (HV) with the responsibility for implementing, administering and monitoring the application of the requirements of this document. The person appointed to fill this position needs to have a commitment to the role and the responsibilities which it involves, and should preferably be independent of the organisation. The management who are responsible for the appointment also have a duty to monitor the effectiveness of the Authorising Engineer (HV) in fulfilling this role. This monitoring requirement is particularly important if the Authorising Engineer (HV) is either self-employed or employed by an organisation outside the management

structure. [Appendix 3](#) contains an audit procedure and forms.

- 3.7 The operation and servicing of high voltage equipment in accordance with clearly defined rules and procedures should be entrusted only to persons who are technically competent and appropriately trained. These will be appointed in writing as “Authorised Persons (HV)” or “Competent Persons (HV)”.
- 3.8 It is strongly recommended that management should aim to become independent in respect of the management of the operation of their high voltage installations. This should be achieved by recruiting and training suitable staff for the purpose. Alternatively, where this is not considered justified, it will be necessary to make arrangements using an independent organisation (that is, a local distribution network operator or other suitable contractor). In all instances, it is essential that Authorised Persons (HV) are appointed to deal with switching.
- 3.9 The extent to which control of systems and/or equipment is delegated to an independent organisation may take into account the inherent risks involved to patients and/or sensitive equipment and the complexity of the installation.

Accordingly, it is recommended that a level of control, commensurate with the risk, should be maintained by management personnel.

- 3.10 It should be emphasised that Regulation 3 of the Electricity at Work Regulations 1989 places duties on all those involved with electrical work insofar as they relate to matters under their control. The employment of contractors to carry out electrical work does not allow management to escape responsibility.
- 3.11 Management should establish and maintain a system of equipment registration and control. The system should ensure that all HV electrical equipment and associated buildings for which they have a responsibility, and which is used at establishments which come within their control, is not only suitable for its purpose but is also maintained in an electrically safe and reliable condition.
- 3.12 A formal acceptance procedure is necessary in order to ensure that the entry of all electrical equipment into service is properly administered. Management should also allocate responsibility for ensuring that the appropriate acceptance procedures are initiated, coordinated and carried through.

4 Appointment, roles and duties of personnel

General

- 4.1 Anybody who works on – and is concerned with the control, operation or testing of – equipment to which this safety guidance (HV) applies has the responsibility to ensure that they comply with, and implement, the principles outlined in this guidance together with any relevant codes or procedures. Ignorance of the relevant legal requirements, codes and procedures, and the guidance given in this Health Technical Memorandum may not be accepted as an excuse for neglect of duty.
- 4.2 The responsibilities placed on persons may include all or part of those detailed in this section, depending on the role of the persons.
- 4.3 Any written authorisation given to persons to perform their designated role in implementing this safety guidance (HV) should indicate the class of operation and/or work permitted and the section of system to which the authorisation applies.
- 4.4 Persons involved in achieving safety from the inherent dangers of the system in order to allow work or testing to commence on equipment and its subsequent restoration to service will have separate, broadly identifiable areas of responsibility as follows:
- a. control – including:
 - (i) before work commences – giving instructions on how to implement precautions, and sanctioning the issue of safety documents;
 - (ii) after completion of work – acknowledging cancellation of safety documents and giving instructions on how to restore equipment to service;
 - b. making safe or restoring equipment – including:
 - (i) before work commences – taking action to make equipment safe for work, and issuing safety documents;
 - (ii) after completion of work – cancelling safety documents, and taking action to restore equipment to service;
 - c. work – which includes receipt of a safety document, execution of the required work to its completion, or termination and clearance of the safety document.
- 4.5 It is strongly recommended that the personnel assigned to these roles and duties are only appointed to undertake the duties associated with a single role.

Roles and duties of the Designated Person (HV)

- 4.6 Each healthcare organisation should appoint a person as Designated Person. The roles in relation to this Health Technical Memorandum are described below.
- a. appoint in writing an Authorising Engineer (HV) for all systems and installations for which management has responsibility;
 - b. audit the Authorising Engineer (HV) annually to ensure the Authorising Engineer (HV)'s duties have been carried out in accordance with this Health Technical Memorandum;
 - c. agree any local variations from this guidance.

Role and duties of the Authorising Engineer (HV)

- 4.7 The “Authorising Engineer (HV)” will be responsible for implementing, administering and monitoring the application of this guidance. The Authorising Engineer (HV)'s roles include the following:
- a. assess and recommend in writing sufficient Authorised Persons (HV) to provide the necessary cover for all systems and installations for which management has responsibility;

- b. define the exact extent of the systems and installations for which each Authorised Person (HV) is responsible;
- c. if necessary, recommend the suspension or cancellation of the appointment of an Authorised Person (HV) and withdraw the certificate;
- d. maintain a register of all Authorised Persons (HV);
- e. ensure that candidates for appointment as Authorised Persons (HV):
 - (i) satisfy the qualification requirements;
 - (ii) satisfy the training and familiarisation requirements;
 - (iii) can demonstrate adequate knowledge of each system, installation and type of equipment for which authorisation is sought;
 - (iv) have satisfied the Authorising Engineer (HV) as to their competence and ability.

4.8 The Authorising Engineer (HV) also:

- issues to each Authorised Person (HV), on appointment, a certificate valid for a period not exceeding three years;
- reports to the management any deficiency in the number of suitably trained and experienced Authorised Persons (HV) where this significantly impairs management's ability to provide a safe and efficient service;
- reviews each Authorised Person (HV)'s operational experience at intervals of not more than three years by examining the relevant operating records of the system(s), and recommends refresher training as necessary;
- audits the performance and records the operational experience of each Authorised Person (HV) every 12 months;
- at intervals not exceeding three years, undertakes comprehensive audits, in accordance with the application of this guidance, to all systems and installations;
- on receipt of an "operational restriction" related to high voltage systems and/or equipment, ensures that all Authorised Persons (HV) are made aware of it and receive copies;

- notifies the Department of Health of any known operational restriction issued by a distribution network operator or equipment manufacturer etc, or one which arises locally;
- initiates and coordinates the investigations of reported injuries and dangerous occurrences involving electrical systems and installations within the Authorising Engineer's (HV) sphere of responsibility.

4.9 They should:

- sanction any interpretation of this guidance, any local house rules and any deviation that may be necessary for their application;
- ensure that any amendments to this guidance are brought formally to the attention of, and are understood by, all appropriate personnel;
- notify the management of any known defect reports or operational restrictions issued by a distribution network operator, manufacturer or supplier of electrical equipment which is applicable to equipment within the areas for which the Authorising Engineer (HV) is responsible;
- ensure that a system is in place to circulate relevant information on operating restrictions and dangerous occurrences to all Authorised Persons (HV);
- investigate all dangerous occurrences involving electrical equipment, systems and installations for which the Authorising Engineer (HV) is responsible;
- agree in writing any local deviation from this guidance that may be necessary for their application to a particular item of equipment or location;
- ensure that any amendments to this guidance are brought to the attention of, and understood by, all Authorised Persons (HV).

4.10 At random intervals not exceeding 12 months, the Authorising Engineer (HV) is to review the competency of all Authorised Persons (HV). These reviews should pay particular attention to operating records and the issue and cancellation of permits. He/she should formally advise on any training or retraining considered necessary, including when it should be received. These reviews should include a meeting with the Authorised Person (HV) and a brief inspection of the systems or installations to which their appointment refers.

- 4.11 At intervals not exceeding three years, the Authorising Engineer (HV) is to undertake comprehensive audits of the safe systems of work and safety procedures recommended by this guidance. Separate audits should be carried out for each site or geographical area to which the Authorising Engineer (HV) has been appointed.
- 4.12 A written report of the audit should be compiled, listing satisfactory items seen and any deficiencies found, and recommendations made. This should be issued to a Duty Authorised Person (HV) for action as necessary. A copy of the report with a summary of the findings should be issued to the director with responsibilities for engineering.
- 4.13 The Duty Authorised Person (HV) is to acknowledge receipt of the audit report, make any comments considered necessary and compile an action plan in consultation with the Authorising Engineer (HV). The Authorising Engineer (HV) should review the progress on the action plan at the next audit.
- 4.17 Where there is more than one Authorised Person (HV) appointed for a system or installation, the Authorising Engineer (HV) should be advised of any Authorised Person (HV) who is nominated as being in overall charge with responsibility for control of records etc.
- 4.18 The duties of Authorised Persons (HV) may be summarised as follows:

- a. control the work on high voltage systems, prepare inspection, maintenance and safety programmes, and progress the work;
- b. ensure that all records concerning high voltage systems are kept up-to-date;
- c. record all high voltage switching operations;
- d. ensure that test equipment is maintained in good condition;
- e. cooperate with the Authorising Engineer (HV) in matters of policy concerning high voltage systems;
- f. report in writing any dangerous and/or unusual occurrences to the Authorising Engineer (HV);
- g. appoint in writing Competent Persons (HV), and maintain a register of all appointments;
- h. define the duties of appointed Competent Persons (HV) on the “certificate of appointment”;
- j. ensure that the necessary safety posters are displayed in substations at all times;
- k. issue and cancel safety documents;
- m. routinely inspect and test substation earthing;
- n. routinely inspect and test transformers and switchgear;
- p. routinely inspect and test high voltage protection systems including batteries.

Roles and duties of the Authorised Persons (HV)

- 4.14 The Authorised Person (HV) should be solely responsible for:
- the practical implementation and operation of this guidance; and
 - the systems and installations for which management is in control of danger and for which the Authorised Person (HV) has been appointed.
- 4.15 The Authorised Person’s (HV) instructions and decisions on electrical matters may be considered final and should be complied with. In the case of a dispute, the Authorised Person (HV) is to stop the work or test and refer the matter to the Authorising Engineer (HV) for adjudication.
- 4.16 More than one Authorised Person (HV) may be appointed for a system or installation but, at any one time, only one Authorised Person (HV) should be on duty. Each transfer of responsibility between Authorised Persons (HV) should be recorded in the HV logbook. The name of the Duty Authorised Person (HV) on duty should be readily available and should be displayed behind the glass of the mimic diagram or near the working key cabinet in a position that can only be altered by an Authorised Person (HV) using an Authorised Person (HV) key.
- 4.19 The Authorised Person (HV) should inform the Authorising Engineer (HV) of:
- a. any defects found in electrical equipment;
 - b. any dangerous occurrence;
 - c. any dangerous practices observed in the course of his duties.
- 4.20 The Authorised Person (HV) also:
- arranges for, supervises or undertakes cable detection or location work within the

- geographical area of the Authorised Person (HV)'s appointment;
 - appoints Competent Persons (HV) for defined work within the HV switchrooms and maintains a register of Competent Person (HV) appointments including dates of appointment, the date the appointment is due to expire, details of training and training dates. This register should be kept in the operational procedure manual with copies of all current Competent Person (HV) certificates;
 - ensures that all records for the system for which the Authorised Person (HV) is appointed are completed and kept up-to-date.
- 4.21 Authorised Persons (HV) are to monitor the performance of all Competent Persons (HV) in carrying out their duties under this safety guidance. Monitoring should be carried out continuously and is to include:
- a. visiting work sites and communicating on safety issues;
 - b. visiting substations, switchrooms and electrical enclosures to ensure high standards of tidiness and availability of appropriate safety equipment every three months;
- 4.22 Authorised Persons (HV) are to take action to rectify and report in writing to the Authorising Engineer (HV) on any deficiencies found. A copy of this report should be placed in the operational procedure manual.
- ## Role and duties of the Competent Person (HV)
- 4.23 Competent Persons (HV) should comply with this safety guidance (HV) when carrying out work, whether instructions are issued orally or in writing.
- 4.24 Competent Persons (HV) should use safe methods of work, safe means of access and the personal protective equipment and clothing provided for their safety.
- 4.25 Competent Persons, when recipients of a safety document, should:
- a. be fully conversant with the nature and the extent of the work to be done;
 - b. read the contents and confirm to the person issuing the safety document that they are fully understood;
 - c. during the course of the work, adhere to, and instruct others under their charge to adhere to, any conditions, instructions or limits specified on the safety document;
 - d. keep the safety document and (where appropriate) keys in safe custody, and correctly implement any management procedure to achieve this;
 - e. when in charge of work, provide immediate or personal supervision as required;
 - f. warn all persons as quickly as possible to withdraw from, and not to work on, the equipment concerned until further notice if, during the course of work, a hazard which could result in danger arises or is suspected. The situation should be reported immediately by the Competent Person (HV) to an Authorised Person (HV).
- 4.26 Competent Persons (HV) should not start or restart work under a safety document issued to another Competent Person (HV).
- 4.27 Having accepted a safety document, the Competent Person (HV) may only undertake or supervise the work or test specified until the task is complete and the Competent Person (HV) has signed part 3 of the permit or sanction-for-test, which is retained in the pad. Neither the Competent Person nor any person under the direct control of the Competent Person (HV) is to attempt to undertake any other duties.
- 4.28 Unless it is unavoidable, the Competent Person (HV) is not to leave the location of the work or test until the task is completed. If the Competent Person (HV) has to temporarily leave the location of the work or test, the task should be suspended, and adequate safety precautions taken to prevent danger. The work or test is not to be resumed until the Competent Person (HV) has returned to the location of the work or test.
- 4.29 Competent Persons (HV) clearing a safety document should do so only after all persons working under the safety document have been withdrawn from, and warned not to work on, the equipment concerned. Where appropriate, they should ensure that all tools, gear and loose material have been removed, guards and access doors replaced and the workplace left tidy.

Role and duties of the Accompanying Safety Person (HV)

- 4.30 The Accompanying Safety Person (HV) is a person, not directly involved in the work or test, who should have adequate knowledge, experience and the ability to avoid danger. They are required to keep watch, prevent unauthorised interruption of the work or test, be able to apply first-aid and summon help.
- 4.31 The Accompanying Safety Person (HV) should have received training in emergency first-aid in accordance with this guidance.
- 4.32 The Authorised Person (HV) or the Competent Person, as appropriate, who will be responsible for the work or test to be attended is to ensure that the Accompanying Safety Person understands their intended role and fully understands how to disconnect the equipment being worked on or tested from all sources of supply and how to switch off any test equipment or disconnect it from its source of supply.
- 4.33 The Accompanying Safety Person (HV) should be in attendance when the Duty Authorised Person (HV) considers it necessary, and in the following circumstances:
- while equipment is being proved or confirmed dead;
 - while equipment is being earthed, other than by means of a switch or circuit breaker;
 - where equipment cannot be confirmed dead until the Competent Person (HV) has made conductors accessible;
 - while the Authorised Person (HV) is spiking a cable;
 - while testing is being undertaken at high voltage;
 - while a high voltage potential indicator is in use;
 - while voltage and phasing tests are being undertaken at high voltage;
 - while any person is opening or working in a high voltage enclosure.

Appointment of an Authorising Engineer (HV)

- 4.34 An Authorising Engineer (HV) should be appointed in writing by the management. Model letters of appointment are given in [Appendix 2](#).
- 4.35 An Authorising Engineer (HV) should be appointed or re-appointed for defined systems and installations for no longer than five years.
- 4.36 A person should be nominated by the Authorising Engineer (HV) and appointed by the management to provide absence cover or deputise for the Authorising Engineer (HV). Any person appointed, as far as is reasonably practicable, should meet the criteria set out in this guidance and be acceptable to the management.

Appointment and re-appointment of an Authorised Person (HV)

- 4.37 An Authorised Person (HV) should be appointed (or re-appointed) by the management or on the recommendation of the Authorising Engineer (HV) for defined systems and installations, for periods not exceeding three years. Appointment and re-appointment should be by the issue, and acceptance, of a letter of appointment signed personally by the Authorising Engineer (HV) and by the management. Letters of appointment (or re-appointment) and acceptance of the appointment should be in the form illustrated in [Appendix 2](#).

Review of an Authorised Person (HV)'s appointment

- 4.38 Each Authorised Person (HV)'s appointment should be reviewed by the Authorising Engineer (HV) at intervals not exceeding three years and prior to re-appointment.

Refresher training for an Authorised Person (HV)

- 4.39 All Authorised Persons (HV) should successfully complete an Authorised Persons (HV) refresher training course at intervals not exceeding three years.
- 4.40 All Authorised Persons (HV) should successfully complete an emergency first-aid training course in accordance with this guidance at intervals not exceeding three years.

Suspension of an Authorised Person (HV)'s duties

- 4.41 The appointment of an Authorised Person (HV) may be suspended or cancelled by the Authorising Engineer (HV), who should take the following actions:
- inform (in writing) the Authorised Person (HV), giving the reasons for the suspension or cancellation, details of any further training or experience considered necessary before re-appointment, and the expected duration of the suspension or cancellation;
 - arrange a meeting with the Authorised Person (HV) to discuss the suspension or cancellation and any action necessary to maintain the availability of an Authorised Person (HV);
 - retrieve the original certificate of appointment;
 - in the case of cancellation, the Authorising Engineer (HV) is to destroy the original certificate and overwrite all other copies with the word “cancelled” followed by the date and his signature.
- 4.42 On suspension or withdrawal of an appointment, the combination of the Authorised Person (HV)'s key safe should be changed.
- 4.43 The Authorising Engineer (HV) should take the necessary action to ensure alternative cover is provided.

Appointment of a Competent Person (HV)

- 4.44 Appointment of a Competent Person (HV) will be by the issue of a safety document.
- 4.45 To be eligible for appointment, prospective Competent Persons (HV) should:
- be competent to undertake work on, and testing of, the types of system and equipment for which the appointment is sought;
 - be familiar with the types of installation and equipment that they will be required to work on or test;
 - possess the necessary technical knowledge, skill and experience relevant to the nature of the work or tests to be undertaken to prevent danger and injury;

- have an adequate knowledge of the relevant parts of this guidance, any agreed local variations, and regulations which are applicable to the installations and equipment on which work or tests are to be undertaken;
- have an adequate knowledge of first-aid, and – within the last three years – have successfully completed an emergency first-aid training course.

- 4.46 If an Authorised Person (HV) is of the opinion that a Competent Person (HV) is not carrying out work in accordance with this guidance, or is working in an unsafe manner, the Authorised Person (HV) is to stop the work, have the equipment or installation made safe, and have the Competent Person (HV) removed from the working area.

Appointment of a Competent Person (HV) via a certificate of appointment

- 4.47 A Competent Person (HV) should be formally appointed in writing by an Authorised Person (HV) for duties which should be clearly defined on the “certificate of appointment”. Appointment will be by the issue and acceptance of the certificate, signed by an Authorised Person (HV).
- 4.48 Details of the recommended procedure, pro forma and certificates are given in [Appendix 2](#).
- 4.49 A copy of the certificate should be placed in the operational procedure manual.
- 4.50 The Authorised Person (HV) should maintain a register of all Competent Person (HV) appointments. Each Competent Person (HV)'s appointment should be reviewed by the Authorised Person (HV) at intervals not exceeding one year and by each new Authorised Person (HV) as soon as practicable after appointment.
- 4.51 A copy of the appointment record and review details should be placed in the operational procedure manual.

Suspension of a Competent Person (HV)'s duties

- 4.52 The appointment of a Competent Person (HV) may be suspended or cancelled by an Authorised Person (HV) or the Authorising Engineer (HV), who should take the following action:

- a. retrieve from the Competent Person (HV) the certificate of appointment, substation key(s) for high voltage systems, and any other related items issued under the appointment procedure;
- b. destroy the original certificate and overwrite all other copies of the certificate with the word “cancelled”. This must be followed by the date of cancellation and the signature of the Authorised Person (HV) or Authorising Engineer (HV) responsible for the action;
- c. note the cancellation on the Competent Person’s (HV) appointment record;
- d. notify in writing the suspension or cancellation of the appointment to all other Authorised Persons appointed for all systems and installations with which the Competent Person (HV) was associated;
- e. inform in writing the Competent Person (HV), giving the reason for the suspension or cancellation, details of any further training or experience or any further action considered necessary before re-appointment, and the expected duration of the suspension;
- f. arrange a meeting with the Competent Person (HV) where appropriate to discuss the suspension and, where necessary, the cancellation.

Contractor’s Competent Persons (HV)

- 4.53 Where a contractor has been appointed to provide Competent Persons (HV) for a system and installation, it will be the Authorised Person (HV)’s responsibility to ensure that each Competent Person (HV) is of a standard equivalent to that required by this guidance.
- 4.54 If the Authorised Person (HV) is of the opinion that a contractor’s Competent Person (HV) is not working in accordance with the requirements of this guidance, or is working in a dangerous manner, the Authorised Person (HV) has the authority to stop the work.
- 4.55 Where a contractor is providing the services of a Competent Person (HV), the contractor should also be advised of any suspension or cancellation proceedings and be invited to attend any meetings.

5 Demarcation of responsibilities between the management and others

General

- 5.1 Whenever there is a division of responsibilities between management and others, the Authorised Person (HV) appointed by management should issue instructions to other parties, as necessary, to prevent danger.
- 5.2 Where a specialist contractor has been appointed under contract or other arrangement by management, they should be required to comply with:
- management's electrical safety guidance for high voltage systems;
 - the requirements of this Health Technical Memorandum;
 - any instructions issued by management's Authorised Person (HV) in accordance with their electrical safety guidance for high voltage systems.
- 5.3 Where there is a demarcation of responsibilities between the management and others, the Duty Authorised Person (HV) is, on matters relevant to Authorised Persons (HV) duties, to liaise with the other party (or parties) as necessary to avoid danger.
- 5.4 Each demarcation of responsibilities should be recorded in writing and precisely described on a diagram. The point of demarcation must be at a cable termination and should be at the outgoing terminals of a switch or circuit breaker.
- 5.5 Each proposed demarcation of responsibilities should be approved by the Authorising Engineer (HV) before it is finally agreed with the other party (or parties) involved.
- 5.6 A copy of the diagram should be prominently displayed at each substation and switchroom under joint control.
- 5.7 One copy of the agreement, including the diagram, should be sent to the Authorising Engineer (HV), and another should be placed in the operational procedure manual.

- 5.8 Where another organisation transfers control of electrical danger to the management for the duration of a contract, the Authorised Person (HV) appointed by the management to be in control of the electrical danger is to request from the other organisation, details in writing of any known hazards (including potentially explosive atmospheres, polychlorobiphenyls (PCBs) etc) that are, or may be, present. A copy of these details should be placed in the operational procedure manual and another copy should be given to the management contractor(s), if appointed.

Note

The other organisation has a duty to provide such details under Section 4 of the Health & Safety at Work etc Act 1974.

Where the management has control of the danger for part of another organisation's system or installation

- 5.9 The Duty Authorised Person (HV) (or, for a new site, the Authorised Person (HV) Designate) is to liaise with the other organisation's Duty Holder to agree the point of demarcation and the points of contact for both parties. Once the Authorising Engineer (HV) has approved this, the formal agreement should be drawn up and signed by both parties.

Where the management does not have control of the danger for a system or installation

- 5.10 The management staff and the management contractor's staff who are to undertake work or tests on parts of systems or installations for which the management does not have control of the electrical danger are not required to comply with this guidance, but are to comply with the statutory regulations and/or any safety rules and procedures

issued by the organisation having control of the electrical danger.

Where contractors are to undertake installation work on an existing system or installation for which the management has control of the danger

- 5.11 Before any installation work is undertaken by contractors on an existing system or installation for which the management has control of the danger, it is recommended that the person responsible for that installation work is to liaise directly with the Duty Authorised Person (HV) to ensure that the work is undertaken in accordance with this guidance and that contractors' method statements agree and are included in the safety programme.

For new work before the system or installation is accepted from the contractor

- 5.12 During the construction period of the contract, the contractor(s) will have control of the electrical danger and is to comply with all relevant statutory regulations. The contractor(s) is not required to comply with this guidance unless they are imposed by the conditions of contract.
- 5.13 Where it is known that the management will eventually accept control of the electrical danger, it is recommended that the Authorising Engineer (HV), in conjunction with the Duty Holder for the site involved, appoints an Authorised Person (HV) to take responsibility for the new systems or installations when they are officially handed to the management for day-to-day operation and maintenance.
- 5.14 The Authorised Person (HV) should liaise with the contractor's Duty Holder in order to become familiar with the systems or installations for which they will eventually take control of the electrical danger.
- 5.15 Where the contractor's Duty Holder is responsible for part of a system or installation, the exact extent of the contractor's responsibility should be agreed in writing.

Note

Electrical test certificates and the appropriate hand-over certificates for the new installations should be formally accepted from the contractor by the management before the installation is connected to a permanent supply for which management has responsibility.

Where a distribution network operator (DNO) appoints a management Authorised Person to operate DNO equipment

- 5.16 A distribution network operator (DNO) may appoint nominated Authorised Persons (HV) to operate their equipment under defined conditions and in accordance with defined procedures. In such cases, the Authorised Persons (HV) should be nominated by management and the Authorising Engineer (HV) for appointment by the DNO.
- 5.17 Each nominated Authorised Person (HV) is to obtain from the DNO's appointing officer a written agreement defining the responsibilities to be accepted and the regulations and procedures to be followed.
- 5.18 Each nominated Authorised Person (HV) is to acknowledge, in writing, receipt of the agreement from the DNO, and acceptance of the responsibilities after consultation with the Authorising Engineer (HV).
- 5.19 Copies of the agreement and acknowledgement should be sent to the Authorising Engineer (HV) and placed in the operational procedure manual.
- 5.20 A copy of any relevant regulations of the DNO should be available in each nominated Authorised Person's (HV) office and at any other location required by the DNO.
- 5.21 Any action taken by a nominated Authorised Person (HV) on behalf of the DNO is to comply with the DNO's instructions and should be recorded in any documentation required by the DNO, as well as the site logbook.
- 5.22 Authorised Persons (HV) appointed by the DNO should provide advance warning to the DNO and the Authorising Engineer (HV) before relinquishing such an appointment.

6 General precautions

Security and admittance to substations

- 6.1 All access doors to each substation, switchroom and enclosure containing high voltage electrical equipment must be kept securely locked when unattended.
- 6.2 Locks should be identical so that a single key will enable access to be gained to any substation over which management has control or a degree of control on a site.
- 6.3 Each Authorised Person (HV) should be issued with a key and, where considered appropriate under local house rules, a certificated Competent Person (HV) may also be issued with a key.
- 6.4 No person other than an Authorised Person (HV) or Competent Person (HV) may enter a room containing high voltage equipment unless they are accompanied by an Authorised Person (HV) or have receipt of a permit-to-work, sanction-for-test or limitation-of-access issued by an Authorised Person (HV).
- 6.5 The exception to paragraph 6.4 is when the substation is provided with “automatically controlled fire protection”, when the person must be trained for entry into such room.

Operational keys

- 6.6 The following points apply:
 - a. each Authorised Person (HV) should be issued with a personal key to enable them to gain access to all substations and also a key to the key cabinet;
 - b. a spare key, labelled “Authorised Person – duplicate”, should be kept in a glass-fronted box in a constantly manned location on the site. This box should be designed so that the glass front has to be broken to gain access to the key;
 - c. a notice should be affixed near to the glass-fronted box stating: “only the persons listed have authority to break the glass and withdraw

the key”. This should be followed by a current list of Authorised Persons (HV) appointed for the systems and installations to which the key relates. The Authorising Engineer (HV) should ensure that this list is kept up-to-date;

- d. should the spare keys be required, the person concerned should enter their name on a log-sheet to be kept in this key-box and give the reason for requiring the key;
- e. all other keys to operational locks associated with the high voltage system should be kept in the key cabinet when not in use, unless a key safe is being used. The keys for each substation should be kept on a separate key-ring with a clearly labelled plate;
- f. the key cabinet should be kept locked except when keys are being removed from or returned to it. It is important that the key cabinet is kept locked to prevent unauthorised removal of keys.

Key-plate system

- 6.7 There should be one key for each lock provided for the locking of high voltage switchgear. The key for a lock is not to open any other locks provided on a system or installation.
- 6.8 The keys for the high voltage switchgear in each substation should be held on an appropriately-sized key-ring with a key-plate that should bear the identification of the substation, building or item of equipment to which the keys belong, or the purpose for which each key is intended.

Key cabinets

- 6.9 Except for any key-rings in use, the working keys should be kept in a closed and securely locked working key cabinet installed with the mimic diagram and the lockable document cabinet, in a room to which the Authorised Persons have free access at all times.

- 6.10 The working key cabinet key labelled “Authorised Person” should be held either:
- by the Duty Authorised Person (HV) while operating the system or during installation, or while permits or sanctions-for-test are being issued and cancelled; or
 - in the Authorised Person’s (HV) key-box.

Lockable document cabinet

- 6.11 All documents specified in this guidance should be kept in a lockable document cabinet situated in the same room as the working key cabinet. The lockable document cabinet should be kept locked when not in use, and the key kept in the working key cabinet.

Authorised Person (HV)’s key-box

- 6.12 A key-box with a separate lock should be installed adjacent to the working key cabinet. The Authorised Person (HV)’s key should be kept locked in this box when not being used by the Duty Authorised Person (HV). No other keys should be kept in this box. All Authorised Persons (HV) appointed for the system or installations should be given a key for the lock. No other person should receive a key. The lock should be changed whenever it is suspected that the key system has been compromised. If an Authorised Person (HV)’s certificate expires and is not renewed, or is withdrawn, the Authorising Engineer (HV) should ensure that the key to the key-box is returned.

Mimic diagram

- 6.13 Either a glass-covered or an electronic mimic diagram should be provided for any high voltage distribution system that includes a ring circuit, an automatic start generating set or a fixed uninterruptible power supply. A mimic diagram may also include, or be provided for, other electrical systems or installations.
- 6.14 Where provided, the mimic diagram should be permanently installed in the same room as the working key cabinet. The glass cover of the mimic diagram should be kept locked to prevent unauthorised adjustment of the diagram. Adjustment of an electronic mimic is only to be possible using the Authorised Person’s (HV) key or a password.

Note

A mimic diagram should show, as a minimum, the electricity distribution system and equipment that is under the control of the Authorised Person (HV).

- 6.15 The mimic diagram should at all times reflect the current operational state of the system it represents, and any adjustments made should be recorded in the site logbook.

Safety locks

- 6.16 Safety locks should be padlocks that have one key that is different from all other keys in use on the electrical distribution system. Safety locks should be indelibly coloured red, and each safety lock and its key should have the same unique serial number for ease of identification.
- 6.17 Before a permit-to-work is issued, and before a Competent Person (HV) commences work, safety locks must be applied at all points-of-isolation and where circuit main earths are applied.
- 6.18 Before a sanction-for-test is issued, safety locks must be applied at all points-of-isolation, and safety/working locks at all points where additional earths are applied.

Safety key-boxes

- 6.19 A safety key-box is to have two locks, each of which is to have only one key, one being labelled “Safety key-box – Competent Person”, and the other “Safety key-box – Authorised Person”. It should be so arranged that both locks must be released before access can be gained to the contents of the box.
- 6.20 The number of safety key-boxes provided for each site for which Authorised Persons (LV) have been appointed should be decided by the Authorising Engineer (LV):
- each safety key-box should bear the name of the site and a serial number ensuring positive identification within the site;
 - when in use, each safety key-box is to contain the keys to safety locks associated with only one permit-to-work or one sanction-for-test;
 - after the safety locks have been applied, and before a permit-to-work or sanction-for-test is issued, the keys to all the safety locks should be placed in a safety key-box, and both locks of the box should be secured. When the permit or

sanction is issued, the Duty Authorised Person (HV) is to retain the Authorised Person (HV)'s key and give the Competent Person (HV)'s key to the Competent Person (HV);

- d. the Competent Person (HV) is to retain the Competent Person (HV)'s key until the permit-to-work or sanction-for-test is cancelled;
- e. when not in use, the keys to safety key-boxes should be kept in the working key cabinet.

Operation of high voltage switchgear

6.21 The following points apply:

- a. high voltage switching should be carried out by the Duty Authorised Person (HV) or by persons acting under his/her personal supervision, except when necessary to isolate in an emergency when a Competent Person (HV) will have access to substations in which emergency tripping facilities are available. That person, without delay and with some urgency, must advise the Duty Authorised Person of the action taken. These circuit breakers will be fitted with locks preventing unauthorised reclosure. The Authorised Person (HV) should be informed of all high voltage emergency switching;
- b. locks should be applied as necessary to prevent unauthorised operation of switchgear (except emergency tripping as referred to above);
- c. oil circuit breakers (OCBs) should in general be reclosed a maximum of two times after opening under fault conditions. The equipment should be inspected at the first opportunity after opening under fault conditions;
- d. when switchgear shows any sign of defect or malfunction after operating, its condition should be reported immediately to the Authorising Engineer (HV), and it should be examined before further operation;
- e. no high voltage earthing switch should be operated or circuit main earth connection attached or removed except by an Authorised Person (HV);
- f. making live or dead by visual signal, or by prearranged understanding after an agreed interval of time, is not an acceptable practice.

Action in an emergency

- 6.22 First, Authorised Persons (HV) should go to the mimic diagram cabinet. The first Authorised Person on site should display the “work on high voltage system in progress” and the “Authorised Person on site” notices in a prominent position.
- 6.23 Any other Authorised Person (HV) attending the site, on seeing either of these notices, should take no action until he/she has contacted the Authorised Person (HV) who displayed the notice.

High voltage enclosures

- 6.24 No person other than the Duty Authorised Person (HV), using a high voltage potential indicator designed for the purpose, should be engaged in any work activity on or near any live conductor (other than one covered with insulating material so as to prevent danger) where danger may arise.
- 6.25 Except within a high voltage enclosure, access to live conductors should only be possible with the use of a tool or key.
- 6.26 All spout shutters not required for immediate work or operation should, if not otherwise made inaccessible, be locked shut.
- 6.27 A high voltage enclosure should be opened only by the Duty Authorised Person (HV), or a Competent Person (HV) acting on the instruction of, and personally supervised by, the Duty Authorised Person (HV).
- 6.28 A high voltage enclosure may only be entered by:
 - a. the Duty Authorised Person (HV) accompanied by an Accompanying Safety Person (HV);
 - b. a Competent Person (HV) acting on the verbal instructions of, and personally supervised by, the Duty Authorised Person (HV);
 - c. the Competent Person (HV) in receipt of a sanction-for-test, accompanied by an Accompanying Safety Person (HV), when a high voltage enclosure is created as part of the test procedure;
 - d. an assisting Competent Person acting on the verbal instructions of, and personally supervised by, the Competent Person (HV) in receipt of a sanction-for-test, when a high voltage enclosure is created as part of the test procedure.

Dangerous occurrences

- 6.29 A dangerous occurrence should be reported to the Duty Authorised Person (HV) by Competent Persons (HV) as soon as reasonably practicable.
- 6.30 The Authorised Person (HV) is, without delay or as soon as practicable, to send a preliminary report of the dangerous occurrence to the Authorising Engineer (HV).
- 6.31 Any notifications and reports required to satisfy statutory or other management requirements should be issued.
- 6.32 The Reporting of Injuries, Diseases and Dangerous Occurrences Regulations 1995 (RIDDOR) requires certain dangerous occurrences and accidents to be reported to the Health & Safety Executive.
- 6.33 The Authorising Engineer (HV) is to investigate each dangerous occurrence and issue a report to the director with responsibilities for engineering. The report should be sufficiently detailed to enable the sequence of events leading to the occurrence to be determined. Where reasonably practicable, the report is to include photographs taken before any items of equipment involved in the dangerous occurrence are disturbed.
- 6.34 To alleviate potential problems or criticism which may arise at any enquiry into a dangerous occurrence or incident, management should consider:
- the questionable conflict of interests and impartiality of any investigation or subsequent report where it is carried out by those directly involved;
 - the reliability of evidence involving self-judgement.

Operational restrictions

- 6.35 An operational restriction is a specific written instruction issued via the Authorising Engineer (HV) or the Department of Health in the form of a “hazard notice”, “safety action bulletin” or similar official instruction modifying the normal operating procedures associated with a particular type of equipment. Where the operational restriction is initiated by the Authorising Engineer (HV), it should, when relevant, be forwarded to the Department of Health for circulation nationally.
- 6.36 Any known operational restriction imposed or advised by a DNO must be notified without delay

to the Authorising Engineer (HV) and to the Department of Health.

- 6.37 On receipt of an operational restriction, the Authorised Person (HV) should:
- acknowledge the receipt to the Authorising Engineer (HV), indicating whether the equipment is included in the local system(s) or installations;
 - record the receipt in the logbook and the action taken;
 - place a copy signed by each Authorised Person (HV) in the operational procedure manual.
- 6.38 Where the equipment to which the operational restriction refers forms part of the local systems and installations, the Authorised Person (HV) is to:
- place a copy of the operational restriction, signed by each Authorised Person (HV), in the operating and maintenance manual;
 - arrange for any inspection and remedial work required;
 - where the mimic diagram depicts the equipment referred to in the restriction, mark each item on the mimic to indicate the existence of an operating restriction;
 - where considered necessary, fix warning signs on each item of equipment involved and report the satisfactory completion of any remedial works to the Authorising Engineer (HV).

Circuit main earths

- 6.39 The following precautions should be observed when high voltage electrical equipment is to be discharged and earthed:
- the circuit breaker or specially provided earth switch should be used to make the earth connection. Where a circuit breaker is used, the electrical and mechanical trip mechanism should be rendered inoperative. After switching on, the circuit breaker or earth switch should be locked in the earth position while it is the circuit main earth;
 - where (a) is not practicable, the high voltage electrical equipment should be tested to ensure that it is dead and should then be discharged and earthed by an approved earthing lead applied by means of a pole or other approved method in accordance with this document.

- 6.40 The precise location of each circuit main earth should be recorded on the permit-to-work or sanction-for-test.

Earthing leads and connections

- 6.41 Earthing leads and associated clamps should be examined immediately before being used.
- 6.42 They should be of an “approved type” and of adequate capacity to carry the prospective fault current of the system at the point of application. (“Approved type” means “accessories manufactured and tested for the required duty and available from the equipment manufacturer or his recommended supplier for specific use with his equipment”.)
- 6.43 Earthing leads and associated clamps must never be improvised. They should be properly stored, maintained and recorded.

Procedure for the use of earthing leads

- 6.44 The following procedure should be observed when using earthing leads:
- verify that the circuit is dead by means of a voltage indicator of an approved type, the indicator itself being tested immediately before and after use;
 - earthing leads should be connected to the earth system before being secured to phase conductors. They should be secured to the phases only by means of a pole or other approved equipment. Care must be taken to ensure that good contact is made;
 - all phases should be earthed, even if work is to be carried out on one phase only;
 - earthing leads should not be applied in any cell or compartment in which there is any exposed metal live at high voltage;
 - when earthing leads are being removed, they should be disconnected from phase conductors first and the earth system last;
 - the manufacturers’ earthing equipment only should be used for the purpose of earthing spout contacts of switchgear. The insertion of hand or any tool in contact spouts for this purpose is an unacceptable practice.

Earthing equipment

- 6.45 Proprietary earthing equipment should be used where available. When not available, a suitable device designed for the purpose should be used.
- 6.46 Portable earthing equipment should be inspected by the user before and after use.
- 6.47 A Duty Authorised Person (HV) should inspect portable earthing equipment provided by the management every 12 months, and the inspection recorded in the site logbook.

Location of underground cables

- 6.48 Where it is proposed to carry out excavation work on sites for which Authorised Persons (HV) have been appointed, it is the responsibility of the Duty Authorised Person (HV) to ensure that all underground power cables within the proposed areas of excavation are located and their positions marked before the ground is disturbed.
- 6.49 No person should use cable location and tracing devices unless they are competent to do so and have been specifically trained in their use. A certificate should be issued by the instructor on successful completion of the training. A copy of this should be placed in the operational procedure manual.
- 6.50 Training in the use of cable location and tracing devices should normally be given by the manufacturers of the equipment, but alternatively it may be given by a Competent Person (HV) who has been trained and certified by the manufacturers or an approved training provider.

Fire protection equipment

Automatic control

- 6.51 Before work or inspections are carried out in any enclosures protected by automatic fire-extinguishing equipment:
- the automatic control must be rendered inoperative by the Authorised Person (HV) and the equipment left on hand-control. A caution sign should be attached and displayed whenever the automatic fire-extinguishing system is inoperative;
 - precautions taken to render the automatic control inoperative must be noted on any safety document issued for work in the protected enclosure;

- c. the automatic control will be restored by the Authorised Person (HV) immediately after the persons engaged on the work or inspections have withdrawn from the protected enclosure.

Portable extinguishers

- 6.52 Only carbon dioxide (CO₂) or dry-powder extinguishers may be used near live electrical equipment, and a safety clearance of at least 300 mm should be maintained. After the discharge of portable extinguishers in an enclosed space, personnel must withdraw from that space.
- 6.53 After any explosion or fire, or after the discharge of extinguishers in an enclosed space, the space must be thoroughly ventilated before entry of personnel, unless suitable breathing apparatus is worn.

Coolant and arc-extinguishing media

- 6.54 The availability of economic and non-flammable substitutes for hydrocarbon insulating oil, as coolant and arc-extinguishing media, has led to the production of equipment containing these alternative agents and their installation within healthcare premises.
- 6.55 A number of these substitutes under certain conditions can be injurious to the health of employees. Health and safety legislation requires employers to ensure, so far as is reasonably practicable, the health, safety and welfare of their employees. It is essential when using alternative cooling or arc-extinguishing media to ensure that the potential effects under all conditions have been fully investigated and safe working procedures produced to indicate the required action under both normal and emergency conditions, taking into account the environmental conditions.
- 6.56 Members of the emergency services who may attend the site must be made aware of any risks and advised accordingly.
- 6.57 Information on a selection of alternative cooling and extinguishing agents and their potential effects is given in Health Technical Memorandum 06-01 – 'Electrical services: supply and distribution'.
- 6.58 The information contained in Health Technical Memorandum 06-01 should not be taken as an exhaustive list, as inevitably developments in this area will produce other alternatives.
- 6.59 The requirements of the Control of Substances Hazardous to Health (COSHH) Regulations 2002

must be considered when employing alternative cooling or arc-extinguishing agents etc within electrical equipment. In addition, appropriate procedures and actions necessary to protect the health and safety of individuals must be taken.

Note

It should be noted that, under the COSHH Regulations, while the extinguishing agent may not be a listed substance in the formal sense, it may still be a "hazardous substance" in the sense of creating a hazard which is comparable to that caused by a listed substance. The approved Code of Practice on the COSHH Regulations should be referred to for guidance.

Equipment containing sulphur hexafluoride (SF₆)

- 6.60 Work on any equipment containing sulphur hexafluoride (SF₆) should be carried out in accordance with the special instructions specified by the manufacturer (see also Health Technical Memorandum 06-01).
- 6.61 Under normal circumstances, SF₆ is non-toxic; however, when exposed to an electric arc, it decomposes to form toxic compounds which will normally be contained within the equipment. In the rare event of any decomposition products being present in the atmosphere, warning indications such as a pungent odour similar to rotten eggs or irritation of the upper respiratory tract and eyes will become apparent. Where this occurs, personnel should immediately get fresh air even if no equipment failure is apparent. The Authorised Person (HV) must be informed, who should then report the incident to the Authorising Engineer (HV) and manufacturer.
- 6.62 Work on any equipment containing an alternative to hydrocarbon insulating oil as coolant and arc-extinguishing media should be carried out in accordance with any special instructions specified by the manufacturer (see also Health Technical Memorandum 06-01).

Vessels containing oil or flammable liquids

- 6.63 The following points apply:
 - a. prolonged exposure to mineral oils present in transformers and OCBs may lead to skin rashes

and in extreme cases, cancer. Contact with these oils should therefore be avoided whenever possible, and personal protective equipment should always be worn;

- b. smoking and exposed flames are prohibited in the vicinity of open vessels containing, or which have contained, oil or any other flammable substance, until the precautions specified in (b) have been taken;
- c. work on such vessels involving the application of heat is forbidden until all practicable steps have been taken to prevent fire or explosion, either by removal of the flammable substance and any fumes or by rendering them non-explosive and non-flammable.

Access to, and work in, underground chambers, vessels and confined spaces

6.64 The following points apply:

- a. barriers, doors or gates restricting access to underground chambers or similar confined spaces, in which dangerous fumes or other hazards are present or likely to be present, should normally be kept locked and the control of keys be maintained in accordance with an approved procedure;
- b. when any person has to enter any such place or similar confined space in which the above dangers are present or likely to be present, to such an extent as to involve risk of persons being overcome or otherwise endangered, precautions should include the issue of a limitation-of-access safety document in accordance with this document;
- c. arrangements for access and work, and the precautions to be taken, should be in accordance with the Confined Spaces Regulations 1997.

Protective equipment

6.65 Appropriate protective equipment should be provided by management. It should be readily available at all times to those who need it and

have training in its use. It should be worn or used whenever necessary to avoid danger and injury, and as required by this guidance.

- 6.66 Only protective equipment suitable for the purpose should be provided by the management and its contractors. Protective equipment provided by the Competent Person (HV) employed by a contractor may be used if the Duty Authorised Person (HV) agrees. Such use should be recorded on the permit or sanction-for-test.
- 6.67 Protective equipment should be inspected by the user for visible defects before and after use. Any suspect item is not to be used; suspect items should be reported to the Duty Authorised Person (HV), who is to consider its withdrawal and its replacement.
- 6.68 Unless more frequent intervals are specified, a Duty Authorised Person (HV) is to inspect each item of safety equipment provided by the management at least once a year for defects and wear, and is to take remedial action where necessary. These inspections should be recorded in the logbook.

Test equipment

- 6.69 The Duty Authorised Person (HV) is to arrange for the necessary test equipment to be available when required.
- 6.70 Test equipment should be inspected by the user for visible defects on each occasion before and after use.
- 6.71 Unless more frequent intervals are specified, the Authorised Person (HV) is to inspect each item of test equipment provided by the management at least once a year for defects and is to take remedial action where necessary. These inspections should be recorded in the logbook.
- 6.72 Test equipment should be maintained and, where appropriate, recalibrated in accordance with the manufacturer's instructions.
- 6.73 The location of protective equipment, test equipment and portable earthing equipment should be prominently displayed adjacent to the working key cabinet.

7 Safety precautions and procedures for work on high voltage equipment

General

- 7.1 This guidance does not apply where equipment has been isolated, discharged, disconnected and removed from the system or installation.
- 7.2 Equipment that is considered by an Authorised Person (HV) to be in a dangerous condition should be isolated elsewhere and action taken to prevent it from being reconnected to the electricity supply.
- 7.3 All working on, or testing of, high voltage equipment connected to a system should be authorised by a permit-to-work or a sanction-for-test following the procedures set out in Tables 1 and 2 at [paragraph 7.33](#).
- 7.4 No hand or tool (unless the tool has been designed for the purpose) must make contact with any high voltage conductor unless that conductor has been confirmed dead by an Authorised Person (HV) in the presence of the Competent Person (HV).
- 7.5 Where any work or test requires an Accompanying Safety Person (HV) to be present, he/she should be appointed before that work or testing can begin.
- 7.6 Voltage test indicators should be tested immediately before and after use against a test supply designed for the purpose.
- 7.7 Where the procedures involve the application of circuit main earths, the unauthorised removal of such earths should be prevented, wherever practicable, by the application of safety locks.
- 7.8 Where the procedures involve the removal of circuit main earths, that is, testing under a sanction-for-test, the earths will be secured with working locks. The keys to these locks will be retained by the Duty Authorised Person (HV), who will remove and replace the earths as requested.

Identification and spiking of HV cables

- 7.9 Before the conductors of a cable are cut or exposed, the cable and the point-of-work on the cable must be identified with certainty.

- 7.10 The identification may be regarded as clear and certain if the cable can be clearly seen between a point-of-isolation and the point-of-work or if a rope loop is passed along those parts which are not visible.
- 7.11 Where a cable cannot be identified with certainty, the cable route plans for the site should be consulted. The cable should then be identified by signal injection via the cable cores using a cable identifier. The cable should then be spiked at the point-of-work.
- 7.12 The spiking of cables must only be carried out by a person who has been specifically trained in the operation of the equipment in the presence of the Duty Authorised Person (HV).

Precaution prior to live voltage and phasing checks

- 7.13 Where live phasing is to be undertaken, the area containing exposed live conductors should be regarded as a high voltage test enclosure.
- 7.14 Approved equipment used for live voltage and phasing checking at high voltage should be tested immediately before and after use against a high voltage test supply.
- 7.15 Live voltage and phase checking on high voltage equipment may only be undertaken by a Duty Authorised Person (HV), with assistance if necessary from a Competent Person (HV) acting on verbal instructions from the Duty Authorised Person (HV). Neither a permit-to-work nor a sanction-for-test is required, but the Duty Authorised Person (HV) and any assistant should be accompanied by an Accompanying Safety Person (HV).

Testing at high voltage

- 7.16 Where high voltage tests are to be undertaken, a sanction-for-test should be issued to the Competent Person (HV) who is to be present throughout the duration of the tests.

7.17 The areas containing exposed live conductors, test equipment and any high voltage test connection should be regarded as high voltage enclosures.

High voltage test enclosures

7.18 Unauthorised access to a high voltage test enclosure should be prevented by, as a minimum, red and white striped tape not less than 25 mm wide, suspended on posts, and by the display of high voltage danger signs. An Accompanying Safety Person (HV) or the Duty Authorised Person (HV) should be present throughout the duration of the tests, and the area should be continually watched while testing is in progress.

Withdrawable equipment

7.19 Voltage transformers must not be removed or replaced if any of the windings are energised. If they need to be removed, the equipment supplying the voltage transformer must be isolated.

7.20 When withdrawable electrical equipment has been disconnected from all supplies and withdrawn from its normal live position, its conductors must be discharged to earth but need not remain connected to earth. The enclosure and any shutters should be locked off.

Work on remotely and automatically controlled electrical equipment

7.21 Before work is carried out on remotely or automatically controlled equipment such as circuit breakers, isolators, tap-changing gear or associated air compressors, all remote-control and automatic features should first be rendered inoperative. No work must be carried out on the controlling equipment, wiring or relays except by the Authorised Person (HV) or Competent Person (HV) working under the personal supervision of the Authorised Person (HV).

Electrical equipment which can be made live from a DNO's supply system

7.22 Except in an extreme emergency, any switching which may affect a DNO's network should be carried out with the full knowledge and agreement of the DNO's distribution control engineer concerned. The switching operation should be recorded by the Authorised Person (HV).

7.23 Switching to the distribution control engineer's instructions, or with his/her consent, should be carried out without undue delay. All switching – whether to a distribution control engineer's instructions or with his consent, or under conditions of emergency – should be reported to the distribution control engineer as soon as possible after each operation.

7.24 Where work is to be carried out on electrical equipment which is directly connected to a DNO's high voltage network, then switching, earthing, the depositing of safety keys in the key safes, and the issuing of any permit-to-work or sanction-for-test should be the responsibility of an Authorised Person (HV) appointed by the distribution network operation.

Work on busbar spouts of multi-panel switchboards

- 7.25 When work is to be carried out on busbar spouts, the following operations should be carried out in strict sequence:
- the Authorised Person (HV) should record the details of necessary safety precautions and switching operations on a safety programme and produce an isolation and earthing diagram;
 - the section of the busbar spouts on which work is to be carried out must be isolated from all points of supply from which it can be made live;
 - the isolating arrangements should be locked so that they cannot be operated, and shutters of live spouts locked shut. Caution signs should be fixed to the isolating points;
 - where applicable, danger signs should be attached on or adjacent to the live electrical equipment at the limits of the zone in which work is to be carried out;
 - busbars should be checked by means of an approved voltage indicator to verify that they are dead, the indicator itself being tested immediately before and after use. The checking with the voltage indicator should be done on the panel to which the circuit main earths are to be applied. This test should also be made on the panel on which the work is carried out;
 - circuit main earths should be applied at a panel on the isolated section of the busbar other than that at which work is to be done using the method recommended by the switchgear

manufacturers. The insertion of hands or any tool into the contact spouts for this purpose is not an acceptable practice;

- g. an earth connection should also be applied to all phases at the point-of-work;
- h. the permit-to-work should be issued to cover the work to be done. During the course of the work, where applicable, the earth connection(s) at the point-of-work may be removed one phase at a time. Each phase earth connection must be replaced before a second-phase earth connection is removed;
- j. on completion of the work, the permit-to-work should be cancelled.

Work on feeder spouts, voltage transformer spouts or single-panel busbar spouts

7.26 When work is to be carried out on feeder or voltage transformer spouts, or on busbar spouts of a single panel, the following operations should be carried out in strict sequence:

- a. the Authorised Person (HV) should record the details of necessary safety precautions and switching operations on a safety programme and produce an isolation and earthing diagram;
- b. the spouts on which work is to be carried out must be isolated from all points of supply from which they can be made live;
- c. the isolating arrangements should be locked so they cannot be operated, and the shutters of live spouts should be locked shut. Caution signs should be fixed to all isolating points;
- d. where applicable, danger signs should be attached on or adjacent to the live electrical equipment at the limits of the zone in which work is to be carried out;
- e. spout contacts should be checked by means of an approved voltage indicator to verify that they are dead, the indicator itself being tested before and after use;
- f. the circuit should be earthed with approved earthing equipment at the point-of-work and where practicable at all points of the isolation from the supply. For the purpose of earthing metal-clad switchgear, approved appliances only should be used. The insertion of hands or any

tools into contact spouts for this purpose is not an acceptable practice;

- g. a permit-to-work should be issued;
- h. during the course of the work, where practicable, the earth connection(s) at the point-of-work may be removed one phase at a time. Each phase earth connection must be replaced before a second-phase earth connection is removed;
- j. on completion of the work, the permit-to-work should be cancelled.

Work on distribution transformers

7.27 When work is to be carried out on the connections to, or the windings of, a distribution transformer:

- a. the Authorised Person (HV) should record the details of necessary safety precautions and switching operations on a safety programme, and produce an isolation and earthing diagram;
- b. the switchgear or fuse gear controlling the high voltage windings should be switched off, and a safety lock and caution sign fitted;
- c. the low voltage windings of the transformer switch or isolator should be switched off, and a safety lock and caution sign fitted, or other physical means should be used to prevent the switch being energised during the course of work;
- d. where applicable, danger signs should be attached on or adjacent to the live electrical equipment at the limits of the zone in which work is to be carried out;
- e. the transformer should be proved dead at the points-of-isolation if practicable;
- f. an earth should then be applied to the high voltage winding via the switchgear and a safety lock fitted. If the proprietary earthing gear is available for the low voltage switchgear, it should be fitted and safety locks applied (it is advisable to retest for dead before fitting this earthing gear);
- g. before a permit-to-work is issued – the Authorised Person (HV) should, at the point-of-work in the presence of the Competent Person (HV), identify and mark the transformer to be worked on. The permit-to-work and the key to the key safe should then be issued to the Competent Person (HV);

- h. if the conductors of the transformer are exposed during the work – the Authorised Person (HV) should confirm dead via a high voltage indicator to the satisfaction of the Competent Person (HV) before any physical contact is made.

7.28 The transformer must be isolated from all common neutral earthing equipment from which it may become live. This does not require the disconnection of solidly earthed neutrals or neutral equipment connected solely to the transformer on which work is to be done.

Work on generators

7.29 When work is to be carried out on the connections to, or the windings of, a generator:

- a. the Authorised Person (HV) should record the details of necessary safety precautions and switching operations on a safety programme and produce an isolation and earthing diagram;
- b. the switchgear supplied by the high voltage windings should be switched off and a safety lock and caution sign fitted. Care should be taken to ensure that any auxiliary supplies are also isolated with safety locks and caution signs are fitted;
- c. the engine starting mechanism should be inhibited and safety locks and caution signs fitted. Caution signs should be fitted to the engine start panel;
- d. where applicable, danger signs should be attached on or adjacent to the live electrical equipment at the limits of the zone in which work should be carried out;
- e. the generator should be proved dead at the points-of-isolation if practicable;
- f. an earth should then be applied to the high voltage winding via the switchgear and a safety lock fitted;
- g. before a permit-to-work is issued – the Authorised Person (HV) should, at the point-of-work in the presence of the Competent Person (HV), identify and mark the generator to be worked on. The permit-to-work and the key to the key safe should then be issued to the Competent Person (HV);
- h. if the conductors of the generator are exposed during the work – the Authorised Person (HV) should confirm dead via a high voltage indicator

to the satisfaction of the Competent Person (HV) before any physical contact is made.

Issuing of a permit-to-work or sanction-for-test

7.30 Before a permit-to-work or a sanction-for-test is issued, the Duty Authorised Person (HV) should identify the equipment on which the work or test is to be undertaken. If the work involves, or may involve, obtaining access to items of equipment over which confusion could occur, the Duty Authorised Person (HV) should identify such items to the Competent Person (HV) and apply temporary marking to them.

7.31 Before issuing a permit-to-work or sanction-for-test, the Authorised Person (HV) should show the Competent Person (HV) the isolation and earthing diagram and indicate the safety arrangements at the points-of-isolation and at the point-of-work or test. The Authorised Person (HV) should ensure that the Competent Person (HV) understands all the relevant safety procedures and precautions. If the Competent Person (HV) thereafter accepts the permit or sanction, that person becomes responsible for the defined work or test until the permit or sanction is cancelled.

7.32 Authorised Persons (HV) undertaking tasks requiring permits-to-work or sanctions-for-test should issue the documents to themselves. All such documents must be countersigned by a site-certified Authorised Person (HV) before the work or test starts. The Authorised Person (HV) then becomes the Competent Person (HV).

Summary

7.33 **Tables 1–2** summarise the procedures to be carried out for work/tests undertaken on high voltage equipment.

Table 1 Procedures to be carried out by an Authorised Person (HV) to enable work on high voltage equipment

Steps ¹	Procedure
1 Prepare a safety programme	<ul style="list-style-type: none"> (i) Prepare a safety programme plus an isolation and earthing diagram in duplicate, and obtain countersignatures from another Authorised Person (HV). (ii) Before any work can begin, obtain permission from the manager in charge of the area to be affected by the work. (iii) Sign on as the Duty Authorised Person (HV), and place notices in mimic.
2 Isolate and fix signs	<ul style="list-style-type: none"> (i) Isolate from all sources of supply. (ii) Prevent unauthorised connection by fixing safety locks and caution signs at points-of-isolation. (iii) Fix danger signs on live equipment adjacent to the point-of-work.
3 Prove dead	<ul style="list-style-type: none"> (i) Prove dead with a high voltage potential indicator at all accessible points-of-isolation. (ii) Where appropriate, prove dead on the low voltage side of a transformer, that is LV feed pillars, LV distribution boards etc.
4 Earth	<ul style="list-style-type: none"> (i) Earth conductors at all points-of-isolation and fix safety locks to earths. (ii) Identify with certainty or spike underground cables at the point/s of work if the conductors are to be cut or exposed. (iii) Earth overhead lines near the working places.
5 Issue the permit-to-work	<ul style="list-style-type: none"> (i) The Competent Person (HV) is to be shown the safety arrangements at all the point/s of isolation and at the locations of the work, and is to initial the isolation and earthing diagram. (ii) Mark the point-of-work. (iii) Issue the permit-to-work, isolation and earthing diagram, and the key to the safety key box to the Competent Person (HV). (iv) Adjust mimic diagram and complete the site logbook.
6 Undertake the work	The Competent Person (HV) is to undertake or directly supervise the work and on completion, or when the work is stopped and made safe, is to return the original of the permit-to-work, the isolation and earthing diagram and the Competent Person's (HV) key to the safety key box to the Duty Authorised Person (HV), and complete part 3 of the permit retained in the pad.
7 Check the equipment	If the work has been completed, check to ensure it is safe to energise. If the work has been stopped, check the equipment has been made safe.
8 Cancel the permit-to-work	<ul style="list-style-type: none"> (i) Cancel the permit-to-work by signing part 4 and by destroying the permit in the presence of the Competent Person (HV). (ii) File the isolation and earthing diagram in the operational procedure manual. (iii) Return key to key safe.
9 Restore to operational state	<ul style="list-style-type: none"> (i) If the equipment requires testing, follow the procedure in Table 2. (ii) Remove safety locks and earths applied in step 4. (iii) Remove safety locks and signs applied in step 2. (iv) Restore equipment to an operational state. (v) Adjust mimic and complete site logbook

Notes:

1 The Authorised Person (HV) is responsible for all tasks.

Table 2 Procedures to be carried out by an Authorised Person (HV) to enable testing on high voltage equipment

Steps ¹	Procedure
1 Prepare a safety programme	<ul style="list-style-type: none"> (i) Prepare a safety programme plus an isolation and earthing diagram in duplicate, and obtain countersignatures from another Authorised Person (HV). (ii) Before any test can begin, obtain permission from the manager in charge of the area to be affected by the test. (iii) Sign on as the Duty Authorised Person (HV), and place notices in mimic.
2 Isolate and fix signs	<ul style="list-style-type: none"> (i) Isolate from all sources of supply. (ii) Prevent unauthorised connection by fixing safety locks and caution signs at points-of-isolation. (iii) Fix danger signs on live equipment adjacent to the point of the test. (iv) If a high voltage enclosure is needed, set up barriers and fix danger signs.
3 Prove dead	<ul style="list-style-type: none"> (i) Prove dead with a high voltage potential indicator at all accessible points-of-isolation. (ii) Where appropriate, prove dead on the low voltage side of the transformer, that is LV feed pillars, LV distribution boards etc.
4 Earth	<ul style="list-style-type: none"> (i) Earth conductors at all points-of-isolation. (ii) Fix working locks to earths to enable their removal when required. (iii) Identify with certainty or spike underground cables at the point of test and at the distant end. (iv) Earth overhead lines near the point of test.
5 Issue the sanction-for-test	<ul style="list-style-type: none"> (i) The Competent Person (HV) is to be shown the safety arrangements at all the point/s of isolation and at the locations of the test, and is to initial the isolation and earthing diagram. (ii) Issue the sanction-for-test, isolation and earthing diagram, and the key to the safety key box to the Competent Person (HV). (iii) Retain working lock keys, and remove and replace earths as requested.
6 Undertake the test	<p>The Competent Person (HV) is to undertake or directly supervise the test. On satisfactory completion of the test, or when the test is stopped and made safe, the conductors should be discharged and any earths restored.</p> <p>The Competent Person (HV) should return the original of the sanction-for-test and the key to the safety key box to the Duty Authorised Person (HV), and complete part 3 of the sanction retained in the pad.</p>
7 Check the equipment	<p>If the test has been completed, check to ensure it is safe to energise. If the test has been stopped, check the equipment has been made safe.</p>
8 Cancel the sanction-for-test	<ul style="list-style-type: none"> (i) Cancel the sanction-for-test by signing part 4 and by destroying the sanction in the presence of the Competent Person (HV). (ii) File the isolation and earthing diagram in the operational procedure manual. (iii) Return key to key safe.
9 Restore to operational state	<ul style="list-style-type: none"> (i) Remove safety locks and earths applied in step 4. (ii) Remove safety locks and signs applied in step 2. (iii) Restore equipment to an operational state. (iv) Adjust mimic and complete site logbook

Notes:

1 The Authorised Person (HV) is responsible for all tasks.

8 Operating records

General

8.1 For each site for which Authorised Persons (HV) have been appointed, records are to be kept as listed in the following sections. These records are to be accurate and kept up-to-date.

Site logbook

8.2 For each site for which Authorised Persons (HV) have been appointed, a bound hard-covered book (not loose-leaf) with sequentially numbered pages and titled “site logbook” should be prepared.

8.3 The book is to be clearly and indelibly marked with the name of the site, the location and the system or installation to which it refers, and is to be kept in the lockable document cabinet when not in use.

8.4 The logbook will be retained by, and all entries will be made by, the Duty Authorised Person (HV) appointed for the particular geographical area.

8.5 Entries are to be made in chronological order, each entry being ruled off with a horizontal line across the page. Entries are to show:

- a. the acceptance and relinquishing of responsibility between Authorised Persons (HV);
- b. the removal, return and the transfer of the Authorised Person (HV)’s key from the Authorised Person (HV)’s key box.
- c. each individual operation of high voltage switchgear and the reason;
- d. a summary of the operation of an automatic switching sequence;
- e. adjustment of the mimic diagram to indicate the present state of the system or installation;
- f. the issue and return of any key for high voltage equipment, that is, switchgear, substations, transformers etc;

- g. the issue, cancellation, loss or withdrawal of a permit-to-work, sanction-for-test, or limitation-of-access;
- h. the receipt, termination and remedial action associated with an operational restriction;
- j. the withdrawal or replacement of the Authorised Person (HV)’s duplicate key and of any other duplicate keys.
- k. the annual inspection of protective equipment, test equipment and the six-monthly inspection of portable earthing equipment.

8.6 Completely filled logbooks are to be retained in the lockable document cabinet for a period of three years after the date of the last entry.

Substation logbook

8.7 For each high voltage substation for which the Authorised Person is responsible, a bound hard-covered book (not loose-leaf) with sequentially numbered pages and titled “substation logbook” is to be prepared. The book is to be clearly and indelibly marked with the name of the substation to which it refers and is to be kept in the substation at all times.

8.8 The substation logbook, as shown in [Appendix 1](#), will be printed in black on white paper.

8.9 Entries are to be made in chronological order, each entry being ruled off with a horizontal line across the page. Entries are to show:

- a. every entry into the substation and the reason for entry;
- b. the three-monthly Authorised Person (HV) substation inspections;
- c. (if the room contains an automatic fire suppression system) the time when the system was disabled and the time of enablement.

8.10 Completely filled substation logbooks are to be retained in the lockable document cabinet for a period of three years after the date of the last entry.

Authorised Person (HV)'s logbook

- 8.11 Each Authorised Person (HV) should be issued with a loose-leaf A5 ring-binder containing extracts from this guidance. Entries are to show:
- training courses attended including refresher training;
 - a record of the familiarisation training prior to the Authorising Engineer's interview with the Authorised Person;
 - a record of the Authorising Engineer's initial and subsequent interviews;
 - the date when the Authorised Person (HV)'s duties were accepted;
 - a record of personal switching including times and dates;
 - a record of the Authorising Engineer's annual audit signed by the Authorising Engineer.

Operational procedure manual

- 8.12 For each site for which Authorised Persons (HV) have been appointed, a ring-binder file entitled "Operational procedure manual" is to be prepared.
- 8.13 The binder is to be clearly and indelibly marked with the name of the site, location, system or installation to which it refers and is to be kept in the lockable document cabinet when not in use.
- 8.14 The manual is to contain, in separate sections, a copy of each of the following:
- certificate of appointment issued to a Competent Person (HV), or – for the contractor's Competent Person (HV) – a register of Competent Persons (HV) including details and dates of training, issue dates and review dates of certificates;
 - operational restriction received;
 - inspection report and details of any remedial work undertaken in connection with an operational restriction;
 - cancelled operational restriction;
 - demarcation agreement with other organisations;
 - demarcation agreement with contractors;
 - any operational agreements with a DNO;

- the original copy of every approved and completed safety programme, including any completed and subsequently not used;
- details of protective equipment, test equipment and portable earthing equipment kept within the establishment, including specifications, operators or users' instructions, maintenance instructions and, where appropriate, calibration records;
- a copy of audits carried out in accordance with this guidance.

- 8.15 Each document added to a section of the manual is to be sequentially numbered.
- 8.16 Documents in the manual are to be retained for a period of three years after the date of their cancellation or termination.
- 8.17 The operational procedure manual is also to contain a reference copy of the current edition of Health Technical Memorandum 06-03.

Operating and maintenance manuals

- 8.18 For each geographical area for which Authorised Persons (HV) have been appointed, one or more ring-binder files entitled "Operating and maintenance manual" is to be prepared.
- 8.19 The binder is to be clearly and indelibly marked with the name of the site, location, system or installation to which it refers and kept in the lockable document cabinet when not in use.
- 8.20 The ring-binder is to contain:
- manufacturers' maintenance and operating instructions for each type of high voltage distribution switchgear installed in the system or installation, with test certificates and relevant records;
 - a copy of any current operational restriction applicable to any equipment installed in the system or installation;
 - a copy of the current "as-installed" drawings of the system(s).

Maintenance records

- 8.21 Maintenance records are of value in establishing the frequency of maintenance. Therefore, careful note should be taken of relevant items each time maintenance is performed.

- 8.22 Maintenance records should be initiated when the equipment is installed and should contain at least the following information:
- manufacturer's details including nameplate particulars of the equipment installed, its serial number and manufacturer's order number (if known) and the date of installation;
 - location of the manufacturer's manual and list of recommended spares;
 - date of last maintenance operation and note of the operation counter reading at that time, or an estimate of the number of operations;
 - type of maintenance carried out;
 - record of any findings where the condition of the equipment varied from the expected, action taken, and the condition of important components when the equipment was put back in service;
 - details of fuse-link type and ratings, and relay settings;
 - details of the maximum system fault levels and any changes to them;
 - any special safety requirements.
- 8.23 Every significant fault or breakdown should be recorded and analysed with a view to taking action to prevent its recurrence.

Isolation and earthing diagram

- 8.24 Before any permit-to-work or sanction-for-test is issued, an isolation and earthing diagram should be prepared. This should illustrate the safety arrangements that have been implemented at the points-of-isolation and the place of work to make the equipment safe for the execution of the work or test.
- 8.25 An isolation and earthing diagram will be printed in black on pale-green paper. It will have an original and a duplicate of each page, and each page of a diagram will bear the same pre-printed serial number. Pads of numbered forms must be used in sequence.
- 8.26 An isolation and earthing diagram should show:
- the name, signature and location of the originating Authorised Person (HV);
 - the name, signature and location of the countersigning Authorised Person (HV);
 - the date the countersigned programme is to commence;
 - the purpose of the proposed work or test;
 - the equipment that the proposed sequence of operations will make safe for the work or test to be undertaken;
 - the cables and equipment to be worked on or tested;
 - the points-of-isolation;
 - the points-of-earthing;
 - the points-of-work or test;
 - any safety locks and signs fitted.

Implementing the isolation and earthing diagram

- 8.27 Before commencing the sequence of operations detailed on the countersigned isolation and earthing diagram, the duplicate is to be placed in the operational procedure manual.
- 8.28 The Duty Authorised Person (HV) is to note on the original copy of the isolation and earthing diagram the serial numbers of the safety programme, permit-to-work and sanction-for-test to enable them to be cross-referenced.
- 8.29 The Duty Authorised Person (HV) is to show the isolation and earthing diagram to the Competent Person (HV) indicating the safety arrangements at the points-of-isolation and earthing at the point(s) of the work or test. The Competent Person (HV) will sign the document to indicate an understanding of the safety arrangements in place.
- 8.30 The isolation and earthing diagram is then to be attached to the permit-to-work or sanction-for-test before being issued.

Completion of the work or test

- 8.31 On completion, the original isolation and earthing diagram will replace the duplicate in the operational procedure manual.
- 8.32 All original copies of completed isolation and earthing diagrams are to be retained in the operational procedure manual for three years following the date of implementation.
- 8.33 If the Competent Person (HV) has lost the original of the isolation and earthing diagram, the loss is to be recorded in the site logbook by the Duty

Authorised Person (HV). The Competent Person (HV) is to countersign the duplicate to confirm the loss of the original.

Safety programmes

General

- 8.34 Before any permit-to-work or sanction-for-test is issued, a safety programme, detailing the intended sequence of safety operations to be performed to make the equipment safe for the execution of the work or test, is to be prepared.
- 8.35 A safety programme will be printed in black on pale-green paper. It will have an original and a duplicate of each page, and each page of a programme will bear the same pre-printed serial number. Pads of numbered forms must be used in sequence.

Contents of safety programmes

- 8.36 The safety programme is to be completed in duplicate by the Authorised Person (HV) who will be responsible for issuing the permit-to-work or sanction-for-test, and is to indicate:
- the name, signature and location of the originating Authorised Person (HV);
 - the name, signature and location of the countersigning Authorised Person (HV) if required;
 - the date the countersigned programme is to commence;
 - the purpose of the proposed work or test;
 - the equipment that the proposed sequence of operations will make safe for the work or test to be undertaken;
 - the sequence of operations to be undertaken up to and including the issue of a permit-to-work or sanction-for-test;
 - the location, including any name and identification code, at which each operation is to be performed;
 - the identity of each item of switchgear to be operated (this should be what is stated on the local label on the equipment or alternatively the generic type, manufacturer's name and type reference);
 - the operation to be performed and the reason for the operation;

- any "items required" (for example keys, locks, safety signs, protective equipment, handles, document etc);
 - the requirement for an Accompanying Safety Person (HV) for a specific operation;
 - any intended special instructions or safety measures to be included on the permit-to-work or sanction-for-test;
 - confirmation, where applicable, that prior notification has been given to persons and/or departments who will be affected by the proposed operations and that contingency plans, where required for critical care areas, can be implemented in an emergency.
- 8.37 When a safety programme has been completed, it should be countersigned by another Authorised Person (HV) who has a detailed working knowledge of the particular system involved.

Implementing safety programmes

- 8.38 Before commencing the sequence of operations detailed on the countersigned safety programme, the Duty Authorised Person (HV) is to confirm that the person(s) responsible for the day-to-day operational management of the areas to be affected by the intended work or test are fully aware of the effect this will have on the electrical supplies to the affected area.
- 8.39 Before commencing the sequence of operations detailed on the countersigned safety programme, the duplicate is to be placed in the operational procedure manual.
- 8.40 The Duty Authorised Person (HV) is to refer to the original of the safety programme while carrying out the sequence of operations detailed on the programme.
- 8.41 The Duty Authorised Person (HV) is to note on the original copy of the safety programme the date and time of each switching operation for subsequent entry into the logbook.
- 8.42 The serial number of the isolation and earthing diagram and permit or sanction should be entered on the safety programme as a cross-reference.

Completion of safety programmes

- 8.43 On completion of the sequence of operations detailed on the safety programme, a summary is to be entered in the logbook. This summary should

include the safety programme serial number, start and finish times, and reason.

- 8.44 On completion, the duplicate safety programme should be removed and replaced by the original copy of the safety programme. This is to be retained in the operational procedure manual.
- 8.45 All original copies of completed safety programmes are to be retained in the operational procedure manual for three years following the date of implementation.

Permits-to-work

General

- 8.46 A permit-to-work will be printed in black on pale-blue paper. It will have an original and a duplicate page for part 1 and a single page for parts 2, 3 and 4. Each page of a permit will bear the same serial number. Pads of numbered forms must be used in sequence.
- 8.47 Only one pad of permit-to-work forms is to be used for each geographical area for which an Authorised Person (HV) is on duty.
- 8.48 When not in use, the pads of permit-to-work forms are to be kept in the lockable document cabinet.

Issue and acceptance of permits-to-work

- 8.49 A permit-to-work is not to be issued for any item of equipment for which an existing permit-to-work remains valid, nor for any equipment which is within an area for which a limitation-of-access exists, unless a risk assessment indicated that it is safe to do so.
- 8.50 Except where an Authorised Person (HV) is to undertake the work personally, permits-to-work are to be issued only to Competent Persons (HV).
- 8.51 Duty Authorised Persons (HV) undertaking tasks requiring a permit-to-work are to issue a permit to themselves. The document should be countersigned by another site-certified Authorised Person (HV). The Authorised Person (HV) then becomes the Competent Person (HV).
- 8.52 Permits-to-work with the isolation and earthing diagram attached are to be issued at the location of the work to be undertaken. The issue and cancellation of every permit is to be recorded in the logbook.

- 8.53 Before offering a permit-to-work to a Competent Person, the Authorised Person (HV) is to:
- physically identify, by marking, to the Competent Person (HV) the equipment to be worked on;
 - show the Competent Person (HV) the isolation and earthing diagram which illustrates the safety arrangements at the points-of-isolation and at the point-of-work. Then the Competent Person (HV) will sign to confirm his/her understanding;
 - explain in detail to the Competent Person (HV) the exact extent of the work to be undertaken;
 - draw the attention of the Competent Person (HV) to any special instructions or safety measures noted in part 1 of the permit;
 - demonstrate to the satisfaction of the Competent Person (HV) that the equipment is dead and safe to work on.
- 8.54 Alternatively, the Duty Authorised Person (HV) is to remain with, and supervise, the Competent Person (HV) until conductors have been made accessible to a suitable voltage test indicator and the equipment confirmed dead to the satisfaction of the Competent Person (HV) before the work proceeds.
- 8.55 Exceptionally, for high voltage equipment where it is not practical to prove the equipment dead before issuing a permit-to-work, the Duty Authorised Person (HV), having issued the permit, is to remain with and supervise the Competent Person (HV) until conductors have been made accessible to a suitable high voltage potential indicator (or voltage test indicator for proving dead at the low voltage conductors of a high voltage transformer). The Duty Authorised Person (HV) is then, without any delay, to confirm the equipment dead before allowing the Competent Person (HV) to assume control of the work.
- 8.56 Before the permit-to-work is accepted, the Competent Person (HV) – having understood the work to be undertaken and being prepared to carry it out – is to sign to accept any special instructions or safety measures noted in part 1 of the permit and is to complete and sign part 2. The signature on part 2 renders the original of part 1 of the permit valid for the defined work, which is then issued to the Competent Person (HV).

- 8.57 The Authorised Person (HV) retains the duplicate of part 1 with parts 2, 3 and 4 in the permit pad.
- 8.58 After accepting the permit-to-work, the Competent Person (HV) becomes responsible for personally supervising or undertaking the defined work.
- 8.59 The Competent Person (HV) is not to leave the location of the work or to undertake other work or tests while the defined work is in progress.
- 8.60 During any temporary absence of the Competent Person (HV) from the location of the work, the work is to be suspended and adequate safety precautions taken until the work is resumed on the return of the Competent Person (HV).

Cancellation of the permit-to-work

- 8.61 Having completed the work, withdrawn all persons, materials, instruments and tools from the location of the work and advised all persons associated with the work that it is no longer safe to work on the equipment, the Competent Person (HV) is to complete and sign part 3 of the permit retained in the pad, and return the original of part 1 to the Authorised Person (HV).
- 8.62 Where the work has been stopped, the same procedures apply, but in addition the Competent Person (HV) confirms that the equipment has been made safe pending the issue of another permit-to-work or sanction-for-test.
- 8.63 The Duty Authorised Person (HV) is to check that the work has been satisfactorily completed and that the equipment is safe.
- 8.64 The Duty Authorised Person (HV) is then to cancel the permit by destroying the original part 1 and completing and signing part 4 of the permit retained in the pad.
- 8.65 The isolation and earthing diagram should be retained for filing. The duplicate page of parts 1 and the completed page of parts 2, 3 and 4 are to be retained in the pad.
- 8.66 If the Competent Person (HV) has lost the original of part 1 of the permit, the loss is to be recorded by the Duty Authorised Person (HV) in part 4 of the permit in the pad, and in the logbook.
- 8.67 The Competent Person (HV) is to countersign part 4 to confirm the loss of the original. The loss of a permit is to be reported to the Authorising Engineer (HV).
- 8.68 Completed pads of permit forms are to be retained in the lockable document cabinet for three years after the date of cancellation of the last permit issued from the pad.

Sanctions-for-test

General

- 8.69 A sanction-for-test should be issued by an Authorised Person (HV) to a Competent Person (HV) before any testing of equipment at high voltage begins.
- 8.70 A permit-to-work will be printed in black on pale-yellow paper. It will have an original and a duplicate page for part 1 and a single page for parts 2, 3 and 4. Each page of a sanction will bear the same serial number. Pads of numbered forms must be used in sequence.
- 8.71 Only one pad of sanction-for-test forms is to be used for each geographical area for which an Authorised Person (HV) is on duty.
- 8.72 When not in use, the pads of sanction-for-test forms are to be kept in the relevant lockable document cabinet.
- 8.73 A sanction-for-test is not to be issued for any item of equipment for which an existing sanction-for-test and/or permit-to-work remains valid, nor for any equipment which is within an area for which a limitation-of-access exists.
- 8.74 Except where an Authorised Person (HV) is to undertake the work personally, sanctions-for-test are to be issued only to Competent Persons (HV).
- 8.75 Duty Authorised Persons (HV) undertaking tasks requiring a sanction-for-test are to issue a sanction to themselves. The document should be countersigned by another site-certified Authorised Person (HV). The Authorised Person (HV) then becomes the Competent Person (HV).

Issue and acceptance of sanctions-for-test

- 8.76 Sanctions-for-test are to be issued at the location of the work to be undertaken. The issue and cancellation of every sanction is to be recorded in the logbook.
- 8.77 Before offering a sanction-for-test to a Competent Person, the Authorised Person (HV) is to:

- a. physically identify, by marking, to the Competent Person (HV) the equipment on which the test is to be undertaken;
 - b. show the Competent Person (HV) the isolation and earthing diagram which illustrates the safety arrangements at the points-of-isolation and at the point-of-work. Then the Competent Person (HV) will sign to confirm his/her understanding;
 - c. explain in detail to the Competent Person (HV) the extent of the test to be undertaken;
 - d. draw the attention of the Competent Person (HV) to any special instructions or safety measures noted in part 1 of the sanction;
 - e. demonstrate to the satisfaction of the Competent Person (HV) that the equipment is dead and safe to test.
- 8.78 Exceptionally, for high voltage equipment where it is not practical to confirm the equipment dead before issuing a sanction-for-test, the Duty Authorised Person (HV), having issued the sanction, is to remain with and supervise the Competent Person (HV) until conductors have been made accessible to an approved high voltage potential indicator (or voltage test indicator for proving dead at the low voltage conductors of a high voltage transformer). The Duty Authorised Person (HV) is then to confirm the equipment dead before allowing the Competent Person (HV) to assume control of the test.
- 8.79 Before the sanction-for-test is accepted, the Competent Person (HV) – having understood the test to be undertaken and being prepared to carry it out – is to sign to accept any special instructions or safety measures noted in part 1 of the sanction and is to complete and sign part 2. The signature on part 2 renders the original of part 1 of the sanction valid for the defined test, which is then issued to the Competent Person (HV).
- 8.80 The Authorised Person (HV) retains the duplicate of part 1 with parts 2, 3 and 4 in the sanction-for-test pad.
- 8.81 After accepting the sanction-for-test, the Competent Person (HV) becomes responsible for personally supervising or undertaking the defined test.
- 8.82 The Competent Person (HV) is not to leave the location of the test or to undertake other work or tests while the defined work is in progress.
- 8.83 During any temporary absence of the Competent Person (HV) from the location of the test, the test is to be suspended and adequate safety precautions taken until the test is resumed on the return of the Competent Person (HV).
- ### Cancellation of the sanction-for-test
- 8.84 Having completed the test, withdrawn all persons, materials, instruments and tools from the location of the test and advised all persons associated with the test that it is no longer safe to work on or test the equipment, the Competent Person (HV) is to complete and sign part 3 of the sanction retained in the pad, and return the original of part 1 to the Authorised Person (HV).
- 8.85 Where the test has been stopped, the same procedures apply, but in addition the Competent Person (HV) confirms that the equipment has been made safe pending the issue of another sanction-for-test or permit-to-work.
- 8.86 The Duty Authorised Person (HV) is to check that the test has been satisfactorily completed and that the equipment is safe.
- 8.87 The Duty Authorised Person (HV) is then to cancel the sanction-for-test by destroying the original part 1 and completing and signing part 4 of the sanction retained in the pad.
- 8.88 The isolation and earthing diagram should be retained for filing. The duplicate page of part 1 and the completed page of parts 2, 3 and 4 are to be retained in the pad.
- 8.89 If the Competent Person (HV) has lost the original of part 1 of the sanction, the loss is to be recorded by the Duty Authorised Person (HV) in part 4 of the sanction in the pad, and in the logbook.
- 8.90 The Competent Person (HV) is to countersign part 4 to confirm the loss of the original. The loss of a sanction-for-test is to be reported to the Authorising Engineer (HV).
- 8.91 Completed pads of sanction-for-test forms are to be retained in the lockable document cabinet for three years after the date of cancellation of the last sanction-for-test issued from the pad.
- ### Limitation-of-access
- #### General
- 8.92 In an area or location that is normally under the control of the Duty Authorised Persons (HV) for

electrical safety reasons, a limitation-of-access may be issued by the Authorised Person (HV) for any specified task other than one for which a sanction-for-test or permit-to-work is required.

- 8.93 A limitation-of-access will be printed in black on buff paper.
- 8.94 It will have an original and a duplicate page for part 1 and a single page for parts 2, 3 and 4. Each page of a limitation-of-access will bear the same serial number. Pads of numbered forms must be used in sequence.
- 8.95 Only one pad of limitation-of-access forms is to be in use for each geographical area for which an Authorised Person (HV) has been appointed.
- 8.96 When not in use, the pads of limitation-of-access forms are to be kept in the lockable document cabinet.
- 8.97 Provided that a risk assessment indicates that it is safe, a limitation-of-access may be issued for work to be undertaken in an area or location containing an item of equipment for which a permit-to-work remains valid.
- 8.98 A limitation-of-access should not be issued for any area for which a sanction-for-test remains valid or where a high voltage enclosure has been set up.
- 8.99 Where practicable, all items of live equipment at the location are to be cordoned off from the working area covered by a limitation-of-access for the duration of the work. This should be achieved by temporary barriers, comprising, as a minimum, no-entry warning tape or equivalent prominent markers.
- 8.100 Danger signs are to be prominently displayed on all items of live electrical equipment, at and adjacent to, the location to which the limitation-of-access applies and while it remains valid.
- 8.101 During the period the limitation-of-access remains valid, the Duty Authorised Person (HV) is to arrange for the area involved to be inspected at the end of each working period or day to ensure that:
 - a. any flammable or hazardous materials introduced into the area during the work activity are removed when the activities cease at the end of each working period or day;
 - b. emergency escape routes, emergency exits and access to essential electrical equipment have not been obstructed.

Issue and acceptance of limitations-of-access

- 8.102 A limitation-of-access may be offered to a person of any discipline or specialism who is competent to personally execute the work or to supervise the execution of the work by others.
- 8.103 On accepting the limitation-of-access, that person becomes the Competent Person (HV) and is responsible for undertaking or supervising the work for which the access is required.
- 8.104 Before issuing a limitation-of-access, the Duty Authorised Person (HV) should positively identify the scope and limits of the work to be carried out, and the physical extent of the work at the location.
- 8.105 A limitation-of-access is to be issued at the place where the work is to be undertaken. The issue and cancellation of every limitation-of-access is to be recorded in the logbook.
- 8.106 Before offering a limitation-of-access to the prospective Competent Person (HV), the Authorised Person (HV) is to:
 - a. accompany the prospective Competent Person (HV) to the location where the work is to be undertaken;
 - b. confirm with the prospective Competent Person (HV) in detail the exact extent of the work activities to be undertaken, including the scope and limits;
 - c. show the prospective Competent Person (HV) the area in which the work is to be undertaken;
 - d. indicate to the prospective Competent Person (HV) all items of live electrical equipment in or adjacent to the working area that are to be identified by danger signs;
 - e. draw to the attention of the prospective Competent Person (HV) any special instructions or safety measures noted in part 1 of the limitation-of-access, and indicate the safety measures that have been applied by the Authorised Person (HV).
- 8.107 Before accepting a limitation-of-access, the prospective Competent Person (HV) – having understood the scope, extent and limits of the work to be undertaken, and being prepared to undertake it – is to sign to accept any special instructions or safety measures noted in part 1 and is to complete and sign part 2. The signature on part 2 renders the original of part 1 of the limitation-of-access valid for the defined work and

is issued to the person. The Duty Authorised Person (HV) retains the duplicate pages of part 1 with parts 2, 3 and 4 in the limitation-of-access pad.

- 8.108** The acceptance of the limitation-of-access makes the person responsible for personally undertaking or supervising the defined work. The Competent Person (HV) is not to leave the location of the work or to undertake any other activities while the work is in progress. During any temporary absence of the Competent Person (HV) from the location of the work, the work is to be suspended and adequate safety precautions taken until the work is resumed on the return of the Competent Person (HV).
- 8.109** A limitation-of-access is to be issued at the location of the work to be undertaken. The issue and cancellation of every limitation-of-access is to be recorded in the logbook.

Cancellation of a limitation-of-access

- 8.110** Having completed the work, and having withdrawn all persons, materials, instruments and tools from the working place, the Competent Person (HV) is to complete and sign part 3 of the limitation-of-access in the pad, and return the original of part 1 to the Authorised Person (HV).
- 8.111** When the work has been completed, the Duty Authorised Person (HV) is to check that the location has been left in a clean and tidy condition and is secured against unauthorised access.
- 8.112** The Duty Authorised Person (HV) is then to cancel the limitation-of-access by destroying the original of part 1 and completing and signing part 4 retained in the pad. The duplicate pages of part 1 and the completed page of parts 2, 3 and 4 are to be retained in the pad.
- 8.113** If the Authorised Person (HV) decides to stop the work, the limitation-of-access is to be withdrawn and cancelled. The withdrawal is to be noted in part 4 of the limitation-of-access retained in the pad, and the reasons for the withdrawal and the actions taken are to be noted in the logbook.
- 8.114** If the Competent Person (HV) has lost the original of part 1 of the limitation-of-access, the loss is to be recorded by the Authorised Person (HV) in part 4 of the limitation-of-access retained in the pad and in the logbook.
- 8.115** The Competent Person (HV) is to countersign part 4 to confirm the loss of the original. The loss of a limitation-of-access is to be reported to the Authorising Engineer (HV).
- 8.116** Completed pads of limitation-of-access forms are to be retained in the lockable document cabinet for three years after the date of cancellation of the last limitation-of-access issued from the pad.

9 Display of permanent posters and safety signs

Display of posters

- 9.1 In each room containing high voltage electrical equipment, the following posters should be prominently displayed:
- a poster showing an approved method of treatment for electric shock;
 - extracts from Health Technical Memorandum 06-03;
 - a single line drawing of the high voltage system up to and including final circuit distribution boards under the control of the Authorised Person (HV);
 - if the room contains equipment containing sulphur hexafluoride, a notice stating this should be displayed.
- 9.2 Where management has control of the danger, the Authorised Person (HV) is to carry out an assessment to determine the requirement and location for the display of information in connection with this guidance. Information should be displayed permanently in suitable and prominent positions. The areas to be considered for the display of information in connection with these rules should include every workshop and each Authorised Person (HV)'s office.
- 9.3 Other information and posters to be displayed may include:
- the Electricity at Work Regulations 1989;
 - a poster showing an approved method of treatment for electric shock;
 - other relevant health and safety information.

Design specification

- 9.4 All signs should be to the sizes indicated.
- 9.5 The safety signs shown in Figures 1 and 2 should be designed to the proportions given in the Electricity Safety, Quality and Continuity Regulations 2002.

Figure 1 Safety sign (a)

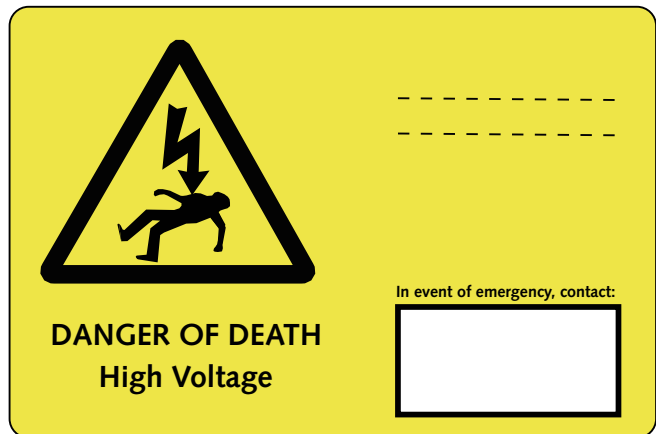

Figure 2 Safety sign (b)



- 9.6 The design and colours of the signs should be to BS 5499-5:2002. Colours should be to BS 5252:1976 as follows:
- yellow 08E51;
 - blue 18E53;
 - red 04E53.

- 9.7 Signs should be manufactured from laminated plastic or other similar non-metallic weather-resistant material (thickness appropriate to the intended location and application).
- 9.8 Non-corrosive materials are to be used when fixing permanent safety signs. Permanent signs should not be fixed with adhesives.
- 9.9 All temporary signs should be provided with two 5 mm diameter holes for a suspension cord. The holes should be 10 mm from the top edge and 30 mm from each end for 150 mm wide signs, and 50 mm from each end for 200 mm wide signs.
- 9.10 Temporary safety signs should be suspended from non-conducting cords, and fixed and removed only by an Authorised Person (HV).
- 9.11 Permanent safety signs are to be securely and permanently fixed in accordance with the clauses in this section.
 - (i) one or more “danger of death” safety signs complying with Schedule 1 of the Regulations;
 - (ii) a property notice giving the unique identification number or location of the substation and an emergency telephone number. Where several substations are located within a single industrial site (for example within a nuclear power station), property notices are still required for each substation for the benefit of infrequent visitors, including staff or contractors, who may observe something untoward in the substation. Each property notice must carry the name of the substation’s current owner or operator.
 - (iii) where necessary, other signs commensurate with the risk of interference, for example “keep out” signs.

Display of permanent safety signs

- 9.12 Where a “gas flooding system” is installed in a substation or accommodation where high voltage is present, a safety sign with appropriate text should be installed in a prominent position.
- 9.13 A warning sign should be displayed on any pole that supports high voltage conductors or equipment.
- 9.14 A warning sign and a notice identifying the installation should be displayed in a prominent position, at every angle of approach, outside every substation and high voltage stand-by set house to comply with table 11C of the Electricity Safety, Quality and Continuity Regulations 2002, which requires duty-holders to erect three types of notice at substations:

Figure 3 Caution sign (actual size: 200 x 100 x 1.5 mm white plastic)



The quantity, size and position of signs should be appropriate to the risk of danger from interference at each location.

- 9.15 The notice giving the unique identification number or location of the substation should be also displayed within the substation adjacent to the single line diagram.

Display of temporary safety signs

- 9.16 Caution signs (see Figure 3) are to be prominently displayed and securely fixed at all points-of-isolation before the start of, and for the duration of, any work or testing, and before the issue of any permit-to-work or sanction-for-test.
- 9.17 Danger signs (see Figure 4) are to be prominently displayed so that they are visible from every angle

Figure 4 Danger sign (actual size: 200 x 100 x 1.5 mm white plastic)

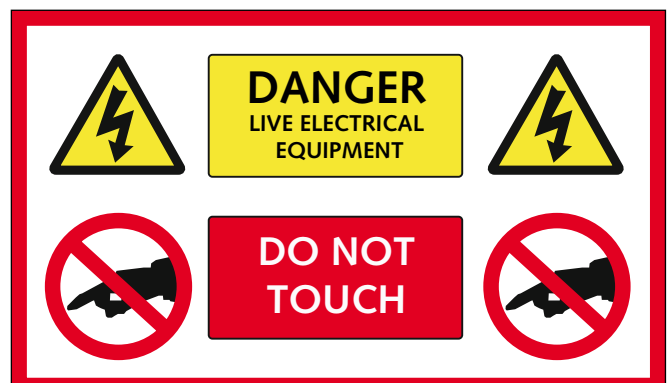

of approach to a high voltage enclosure before any testing at high voltage is carried out and before the issue of, and for the duration of, any work or testing, and before the issue of any permit-to-work or sanction-for-test.

- 9.18** Danger signs are to be prominently displayed on any equipment which remains live and is adjacent to equipment to be worked on or tested before the start of, and for the duration of, the work or testing, and before the issue of any permit-to-work or sanction-for-test.
- 9.19** Where work or testing is to be undertaken on any part of a multi-cubicle switchboard, danger signs

should be prominently displayed on the cubicles or compartments adjacent to the part being worked on or tested. If the board has rear access, danger signs should be similarly displayed at both the front and rear of the board. Reliance is not to be placed on the switchboard labelling when identifying parts at the rear of the board. Any discrepancies found are to be reported.

- 9.20** Danger signs are to be prominently displayed on any equipment which is accessible, both in or adjacent to the area which is the subject of the limitation-of-access, before the issue of and for the duration of any limitation-of-access.

10 Protective, test and earthing equipment

General

- 10.1** This guidance recommends that protective equipment be readily available at all times and is to be worn or used whenever necessary to avoid danger.
- 10.2** Reliance should not be placed on any single item of protective equipment.
- 10.3** The range of protective equipment that may be required for compliance with this guidance at each site for which Authorised Persons (HV) have been appointed could include the following items:
- insulated hand-tools;
 - insulated rubber boots;
 - insulated rubber gloves;
 - insulating rubber mats;
 - face shields (visors);
 - insulating materials for temporary screening;
 - safety-belts and harnesses;
 - cable-spiking equipment;
 - cable-tracing equipment.
- 10.4** The user of any item of protective equipment is to be responsible for carrying out a visual inspection before and after use. If an item is found to be defective or unsafe it is to be reported to the Authorised Person (HV) as soon as possible.
- 10.5** All protective, test and earthing equipment must be stored, inspected, tested and, where appropriate, recalibrated in accordance with manufacturers' recommendations.
- 10.6** All protective, test and earthing equipment is to be inspected by an Authorised Person at intervals recommended by the manufacturer but not exceeding 12 months and the results entered into the logbook. Any item of protective equipment found to be defective is to be destroyed and replaced.

Protective equipment

- 10.7** Competent Persons and Authorised Persons should use appropriate protective equipment when the circumstances require it. Items of protective equipment held or used within a site should comply with any relevant British Standards and should be so kite-marked. British Standards are not available for some of the items of protective equipment recommended.

Protective equipment covered by a British Standard

- 10.8** The following items of equipment are covered by the British Standards indicated:
- insulated screwdrivers – BS 2559-3:1973;
 - insulated pliers – BS 3087-1:1991;
 - rubber gloves for electrical purposes – BS 697:1986 and BS EN 60903:2003;
 - rubber mats for electrical purposes – BS 921:1976;
 - face shields and visors – BS EN 166:2002, BS EN 167:2002 and BS EN 168:2002;
 - safety-belts and harnesses – BS EN 354:2002; BS EN 355:2002; BS EN 361:2002; BS EN 362:2004; BS EN 363:2002; BS EN 364:1993 and BS EN 365:2004.
- 10.9** Face shields and visors should provide protection against electrical flash, impact and molten metal particles.
- 10.10** They should be available to persons who may be exposed to the effects of electric arcs, for example when withdrawing fuses in older types of distribution cubicles.
- 10.11** Many different types of safety-belt and harness are available, each intended for a particular purpose. Safety-belts and harnesses manufactured to the relevant British Standard, and of the correct type,

should be available to persons working in insecure locations, for example on overhead lines.

Protective equipment not covered by a British Standard

- 10.12** Cable spiking equipment in the form of an explosive cartridge-type must be operated in accordance with manufacturers' instructions by a suitably trained person. When using cartridge-operated equipment on small cables, care must be taken where there is a danger of severing the cable.
- 10.13** Insulating material for temporary screening may be required when working on or near live equipment or to separate isolated equipment from adjacent live equipment. Flexible insulating material may be used to prevent breakdown between conductors during high voltage tests. The material used should be suitable for the purpose. The material is to be cut and fixed, as necessary, to suit the particular task.
- 10.14** When using insulating rubber boots as part of a safety system, reliance is not to be placed upon insulating rubber boots alone. There is a danger of metallic objects becoming embedded in the soles without this becoming apparent during inspection.

Voltage test indicators

- 10.15** Authorised Persons and Competent Persons must prove equipment is dead by using a voltage test indicator.
- 10.16** As there is no British Standard for a voltage test indicator in non-hazardous areas, it should comply with the recommendations of the Health and Safety Executive's 'GS38: electrical test equipment for use by electricians'. Test indicators for use on 230/415 V systems should be suitable for use up to 500 V and should indicate a live supply down to 50 V.
- 10.17** In non-hazardous areas, test indicators should be proved before and after use from a known supply.

High voltage test equipment

- 10.18** High voltage potential indicators and proving units should comply with the Electricity Association's Engineering Recommendation 'G9/6 – Voltage testing devices'. Extension rods, end adaptors, and other fittings should be available to suit the equipment on which work is to be undertaken.

Cable-locating devices

- 10.19** When selecting a cable-locating device for a particular task or location, refer to the guidance given by the manufacturer or supplier of the cable-locating equipment.
- 10.20** Cable-locating devices should, as a minimum, be rugged and weatherproof to National Electrical Manufacturers Association standard NEMA 3S (see 'Definitions' in [Chapter 2](#)), comply with the Electromagnetic Compatibility Regulations 2005, and be produced by BS EN ISO 9001:2000-accredited manufacturers.
- 10.21** A cable-locating device that combines all three principles of operation – hum detector (power), radio frequency detector (radio) and transmitter/receiver locator (signal generator) – into one instrument should be selected.
- 10.22** No person should use cable-location and tracing devices unless they are competent to do so, have been specifically trained in their use, and hold a certificate issued by the instructor indicating that the training has been successfully completed. Normally, the manufacturers of the equipment should give training, but alternatively a person who has been trained and certified by the manufacturers may give it.

Earthing equipment

- 10.23** High voltage cables and equipment may be earthed by using integral or portable proprietary earthing devices operating within the equipment enclosure on which the earth is to be applied. An earthing device must be suitable for the use for which it is provided, be maintained in a condition suitable for that use, and be properly used.
- 10.24** Where no proprietary earthing device is available, equipment may be purpose-made. The design must ensure that conductors are capable of carrying the prospective fault current for the time required for back-up protective devices to operate (normally three seconds) without creating danger or injury or damage to equipment.

Substation earthing

- 10.25** All earthing conductors and connections should be inspected at 12-monthly intervals, special attention being given to the more vulnerable parts such as the final connection to earth electrodes and other external parts of the earthing system.

10.26 The earthing systems should be tested annually in accordance with Health Technical Memorandum 06-01 – ‘Electrical services supply and distribution’.

Recommendations for the inspection, test and recalibration of protective, test equipment

10.27 Insulated hand tools should be supplied with a certificate stating that the tools have been electrically tested.

10.28 Rubber gloves should be kept in a dark place where they will not be subjected to mechanical or chemical damage. A container that is clean and free from grease and oil should be provided solely for storing the gloves.

10.29 Before use, each glove should be examined inside and out by the user. Each finger of each glove is to be stretched by hand to ascertain that its mechanical strength is adequate. If either of the gloves is damaged or defective, the pair is to be destroyed and replaced.

10.30 After each use, the gloves are to be inspected by the Authorised Person for surface defects or materials embedded in the surface. If any glove appears defective, the pair is to be destroyed and replaced.

10.31 Gloves that are used frequently are to be tested at intervals not exceeding six months. Gloves that are used infrequently are to be retested after each use, or at intervals not exceeding 12 months, whichever is the more frequent.

10.32 Gloves are to be retested by the manufacturer or locally on equipment described in, and in accordance with, the procedures set out in BS 697:1986.

10.33 Face shields are to be examined by the user before and after use.

10.34 Belts and harnesses are to be stored in a cool, dry place, not subjected to direct sunlight and not subjected to unnecessary strain, pressure, excessive heat or humidity. The equipment is also to be kept free from contact with sharp implements, corrosive substances and other possible causes of damage.

10.35 Where necessary, test equipment is to be inspected and recalibrated at the intervals recommended by the manufacturer.

10.36 The schedule should incorporate:

- a. routine maintenance proposals, based on periodic inspections supplemented at more extended intervals with operational checks and examination as required;
- b. post-fault maintenance, which should be determined by consulting the manufacturer’s handbook and by past experience.

Fire extinguisher installation and equipment

10.37 Inspections and checks should be made in accordance with Firecode document Health Technical Memorandum 05-03, Part A – ‘General fire precautions’ (formerly Health Technical Memorandum 83).

Appendix 1 – Safety documentation (model forms)

Model form numbers

1. Isolation and earthing diagram.
2. Safety programme.
3. Permit-to-work.
4. Limitation-of-access.
5. Sanction-for-test.
6. Logbook.

Serial No



Isolation and earthing diagram
(Complete precisely and legibly in BLOCK CAPITALS)

Safety programme no	Date
Permit-to-work/Sanction-for-test no	Date

Purpose of proposed work/test

Equipment which the proposed sequence of operations will make safe to work on/test

Sketch of isolation and earthing arrangements

Competent Person's initials

Authorised Person		
Signed	Name	Date

Countersigning Authorised Person		
Signed	Name	Date

Sheet of

Serial No



Safety programme

Purpose of proposed work/test* (*Delete as appropriate)	Equipment which the proposed sequence of operations will make safe to work on or test

ITEM No	LOCATION	EQUIPMENT	OPERATION AND REASON	ITEMS REQUIRED	TIME & DATE

Date countersigned programme is required to commence

Authorised Person
 Signed Date

Countersigning Authorised Person
 I hereby declare that I have checked the above Safety Programme, and I am satisfied that, to the best of my knowledge, it will enable the proposed work or test to be carried out safely and in accordance with the 'Electrical Safety Code'. I have knowledge of, and have access to the current diagram of, the system and equipment concerned.
 Signed Date

Serial No
Location



Permit-to-work

(Complete precisely and legibly in BLOCK CAPITALS)

Front – original

Part 1: Issue

Issued to

I hereby declare that it is safe to work on the following electrical equipment which has been made **dead, isolated** from all **live** conductors and, in the case of high voltage equipment, is connected to **earth**:

All other electrical equipment is dangerous to work on

The system is **isolated** and safety locks and **caution** signs fitted at

The equipment is **earthed** and safety locks fitted at

Danger signs are posted

Other precautions taken are

The following work shall be carried out

Authorised Person

Signed Date

Serial No

Location



Permit-to-work

(Complete precisely and legibly in BLOCK CAPITALS)

Front – copy

Part 1: Issue

Issued to

I hereby declare that it is safe to work on the following electrical equipment which has been made **dead, isolated** from all **live** conductors and, in the case of high voltage equipment, is connected to **earth**:

All other electrical equipment is dangerous to work on

The system is **isolated** and safety locks and **caution** signs fitted at

The equipment is **earthed** and safety locks fitted at

Danger signs are posted

Other precautions taken are

The following work shall be carried out

Authorised Person

Signed Date

Back – copy

Part 2: Receipt

I hereby declare that I accept responsibility for carrying out work on the electrical equipment as detailed on this permit-to-work and that no attempt will be made by me or by persons under my control to work on any other electrical equipment I have been shown and have initialled arrangements on the isolation and earthing diagram.

Signed Print name

Time Date

Part 3: Clearance

I hereby declare that the work for which this permit-to-work was issued is now suspended/completed* and that all persons under my charge have been withdrawn and warned that it is no longer safe to work on the electrical equipment specified on this permit-to-work and that all gear, tools etc have been removed.

Signed Print name

Time Date

* *Delete as appropriate*

Part 4: Cancellation

This permit-to-work is hereby cancelled. The original has been returned to me and destroyed in the presence of the signatory to Part 3.

Signed Print name

Time Date

Serial No

Location



Limitation-of-access

(Complete precisely and legibly in BLOCK CAPITALS)

Front – original

1. This form must not be used for work on electrical equipment for which an electrical permit-to-work or sanction-for-test is required.
2. On completion of the work, the holder must surrender this limitation-of-access as directed for cancellation, after which no work shall be done.

Part 1: Issue

Issued to,
 in the employ of, being a Competent Person, is hereby given permission
 to carry out the work described below:

Location

Work

No other work shall be carried out

Remarks

Authorised Person

Signed Time Date

Serial No

Location



Limitation-of-access

(Complete precisely and legibly in BLOCK CAPITALS)

Front – copy

1. This form must not be used for work on electrical equipment for which an electrical permit-to-work or sanction-for-test is required.
2. On completion of the work, the holder must surrender this limitation-of-access as directed for cancellation, after which no work shall be done.

Part 1: Issue

Issued to

in the employ of, being a Competent Person, is hereby given permission to carry out the work described below:

Location

Work

No other work shall be carried out

Remarks

Authorised Person

Signed Time Date

Back – copy

Part 2: Receipt

I hereby declare that I accept responsibility for carrying out work in accordance with this limitation-of-access and no other work will be done by me or the persons under my charge at the location referred to in Part 1 of this document.

Signed Print name
(being the person to whom this form is issued)

Time Date

Part 3: Clearance

I hereby declare that the work for which this limitation-of-access was issued is now suspended/completed* and that all persons under my charge have been withdrawn.

Signed Print name

Time Date

* *Delete as appropriate*

Part 4: Cancellation

This limitation-of-access is hereby cancelled. The original has been returned to me and destroyed in the presence of the signatory to Part 3.

Signed Print name

Time Date

Serial No

Location



Sanction-for-test

(Complete precisely and legibly in BLOCK CAPITALS)

Front – original

Part 1: Issue

Issued to

The following high voltage equipment has been made safe in accordance with 'Safety rules for high voltage systems' for the testing described on this sanction-for-test:

All other electrical equipment is dangerous to work on

The system is **isolated** and safety locks and **caution** signs fitted at

The equipment is **earthed** and working locks fitted at

Danger signs are posted at

Other precautions taken are

The following work shall be carried out

Authorised Person

Signed Name Date

Serial No

Location



Front – copy

Sanction-for-test
(Complete precisely and legibly in BLOCK CAPITALS)

Part 1: Issue

Issued to

The following high voltage equipment has been made safe in accordance with 'Safety rules for high voltage systems' for the testing described on this sanction-for-test:

All other electrical equipment is dangerous to work on

The system is **isolated** and safety locks and **caution** signs fitted at

The equipment is **earthed** and working locks fitted at

Danger signs are posted at

Other precautions taken are

The following work shall be carried out

Authorised Person

Signed Name Date

Back – copy

Part 2: Receipt

I hereby declare that I accept responsibility for carrying out the testing of the electrical equipment as detailed on this sanction-for-test and that no attempt will be made by me or by persons under my control to test any other electrical equipment I have been shown and have initialled arrangements on the isolation and earthing diagram.

Signed Print name

Time Date

Part 3: Clearance

I hereby declare that the test for which this sanction-for-test was issued is now suspended/completed* and that all persons under my charge have been withdrawn and warned that it is no longer safe to work on the electrical equipment specified on this sanction-for-test and that all gear, tools etc have been removed.

Signed Print name

Time Date

* *Delete as appropriate*

Part 4: Cancellation

This sanction-for-test is hereby cancelled. The original has been returned to me and destroyed in the presence of the signatory to Part 3.

Signed Print name

Time Date

Logbook

Date	Time	Location	Circuit or switch concerned	Event or operation and reason	Safety programme and isolation and earthing diagram numbers	Safety document type and serial no	To whom issued	Signature of Authorised Person

Appendix 2 – Model procedures and letters

Appointment procedure for an Authorising Engineer (HV)

- 1 It is the responsibility of the Designated Person to ensure that any person appointed as Authorising Engineer is suitably qualified and adequately experienced to satisfy the requirements of this Health Technical Memorandum, which has been compiled to enable the management to meet its statutory obligation – to comply with the requirements of the Electricity at Work Regulations 1989 for work on electrical equipment.
- 2 Before an Authorising Engineer is appointed, the Designated Person should be satisfied that the prospective Authorising Engineer meets all the criteria set out in [paragraphs 4.7–4.12](#) of this guidance.
- 3 The appointment of an Authorising Engineer is to be by an exchange of letters.

Model letter for appointing an Authorised Engineer (HV)

Dear _____ (*Name of prospective Authorising Engineer*)

OFFER OF APPOINTMENT AS AUTHORISING ENGINEER (HV)

Being satisfied that you are suitably qualified and meet the requirements of paragraphs 4.7–4.12 of Health Technical Memorandum 06-03 – ‘Electrical safety guidance for high voltage systems’, I hereby offer you the appointment of Authorising Engineer for _____ to undertake the duties set out in paragraphs 4.7–4.12 of Health Technical Memorandum 06-03 – ‘Electrical safety guidance for high voltage systems’ until further notice. However this appointment will be reviewed and reconfirmed at three-yearly intervals.

Please confirm your acceptance of this offer of appointment by signing and returning to me a copy of the attached letter.

Yours sincerely

(*Designated Person*)

Model letter for accepting an appointment as an Authorising Engineer (HV)

Dear _____ (*Name of Designated Person*)

ACCEPTANCE OF APPOINTMENT AS AUTHORISING ENGINEER (HV)

I acknowledge receipt of your letter dated _____ offering me appointment as an Authorising Engineer for _____ .

I confirm that, to the best of my knowledge, I satisfy the requirements for appointment as an Authorising Engineer indicated in paragraphs 4.7–4.12 of Health Technical Memorandum 06-03 – ‘Electrical safety guidance for high voltage systems’.

I accept the responsibilities of the Authorising Engineer and will, to the best of my ability, carry out the Authorising Engineer’s duties set out in Health Technical Memorandum 06-03 – ‘Electrical safety guidance for high voltage systems’.

I note that I am required to attend an Authorising Engineer training course at intervals not exceeding three years, an Authorised Person refresher course at intervals not exceeding three years, and a fire-training course at intervals not exceeding 12 months.

Yours sincerely,

(*Authorising Engineer*)

Copies to: Operational procedure manual

Appointment procedure for an Authorised Person (HV)

Part 1: Nomination procedure

Details of proposed appointment						
Type: New appointment						
Dear _____ (<i>Name of prospective Authorised Person</i>) Date _____						
You have been nominated for appointment as an Authorised Person in respect of the system(s), installation(s) and location(s) indicated below:						
1. _____						
2. _____						
Voltage	Types of system or installation	Location (hospitals)				
		1	2	3	4	5
11 kV HV	Ring distribution system					
	Radial distribution system					
	Single generating set installation					
	Multiple generating installation					
	Others (give details of any other HV systems or installations)					
If you agree to be considered for appointment as an Authorised Person for the system(s) and installation(s) indicated at the above location(s), and are willing to accept the appointment, if offered, please complete Part 2 and return it to me as soon as possible.						
Yours sincerely						

<i>(Authorising Engineer (HV))</i>						

Part 2: Personal details

Name _____

Current grade and job title _____

Technical qualifications

Details of apprenticeship

Details of previous experience as an Authorised Person

Courses	Location	Dates

Details of training received

Courses	Location	Dates

Details of first-aid training for electric shock

Course	Date

I confirm that I would be willing to accept the appointment as an Authorised Person electrical for the system(s), installation(s) and location(s) listed in Part 1.

Signed _____ Date _____

Address _____

Part 3: Certification of satisfactory training and familiarisation

Dear _____ (*Name of Authorising Engineer*)

I wish to nominate _____ for appointment as an Authorised Person for the system(s), installation(s) and location(s) as attached.**

Authorised Person training and on-site training have been satisfactorily completed, and I know of no impediment to the discharge of Authorised Person duties.

Would you please arrange to interview the candidate as soon as possible.

Name _____

Signed _____ Date _____

Address _____

** Details should be provided of the site(s) and HV equipment which will be under the control of the nominee.

Model letter for appointing an Authorised Person (HV) by management

Dear _____ (*Name of prospective Authorised Person*)

OFFER OF APPOINTMENT AS AN AUTHORISED PERSON (HV)

You are hereby offered appointment as an Authorised Person (HV) for the duties identified in Health Technical Memorandum 06-03 – ‘Electrical safety guidance for high voltage systems’ for the high voltage systems and installations at (*hospital/ location/healthcare organisation*) for a period of three years, commencing on (*Date*).

Please confirm your acceptance of the appointment and the receipt of the enclosed “Certificate of appointment” by completing and returning the attached letter to me.

You should also sign the certificate of appointment.

Yours sincerely

Assessed by _____ Appointed by _____

(Authorising Engineer (HV)) *(Management)*

Model letter for accepting an appointment as an Authorised Person (HV)

Dear _____ (*Name of Authorising Engineer*)

ACCEPTANCE OF APPOINTMENT AS AN AUTHORISED PERSON (HV)

I accept the appointment as an Authorised Person for the system(s), installation(s) and location(s) indicated in your “offer of appointment” letter dated _____.

I acknowledge receipt of the certificate of appointment number _____ as my authority to act, while on duty, as an Authorised Person for the system(s), installation(s) and location(s) indicated on that certificate.

I note that, while on duty as an Authorised Person, I will be competent for the practical implementation and operation of Health Technical Memorandum 06-03 – ‘Electrical safety guidance for high voltage systems’ for the systems and installations for which _____ have control of the safety, and for which I have been appointed.

I will to the best of my ability follow the procedures as set out in the above Health Technical Memorandum and any written local variations notified to me by or agreed with the Authorising Engineer.

Yours sincerely

Certificate of appointment – Authorised Person (HV)

Certificate of appointment: Authorised Person (HV)

Certificate no _____ Healthcare organisation _____

This is to certify that _____ (*name of appointed Authorised Person*) is appointed an Authorised Person for the purposes of the duties identified in Health Technical Memorandum 06-03 – ‘Electrical safety guidance for high voltage systems’.

The appointment applies only to the locations and to the electrical systems and installations set out below.

The appointment is valid for three years only until

Authorising Engineer

Name _____

Date _____

Authorised Person

Name _____

Date _____

Location(s)	Exact extent of the systems and installations to which this appointment relates

Part 1: Appointment record

Certificate no _____

Name _____

The certificate is valid only for three years until the last expiry date indicated below. After a review a new certificate will be issued and the details recorded below.

Issue	Issue date	Validity (years)	Expiry date	Authorising Engineer's signature
First issue				
First review				
Second review				
Third review				

Notes

Part 2: HV training record

Certificate no _____

Name _____

Course title	Date completed

Part 3: First-aid training record

First-aid training	Date completed

Appointment procedure for a Competent Person (HV)

- 1 It is the responsibility of the Authorised Person to ensure that any person appointed as a Competent Person has suitable training and experience and is competent to satisfy the requirements of paragraphs 4.23–4.29 of this guidance.
- 2 The appointment of a Competent Person is to be by the issue of a certificate of appointment model certificate.
- 3 A prospective Competent Person is to be nominated by the local manager by completing and signing part 1 of an application for appointment of a Competent Person as the model form.
- 4 The prospective Competent Person is to complete and sign part 2 of the application to confirm that they are familiar with the system(s), installation(s) and equipment listed in part 1 of the application.
- 5 Following a successful interview, the Authorised Person will offer an appropriate certificate of appointment to the prospective Competent Person, which is to be formally accepted in writing.

Part 1: Nomination procedure

(To be completed by the Authorised Person)

Details of proposed appointment	
Type: New appointment/renewal/revised coverage*	* <i>Delete as appropriate</i>
Dear _____ (<i>Name of prospective Competent Person</i>) Date _____	
You have been nominated for appointment as an Competent Person in respect of the system(s), installation(s) and location(s) indicated below:	
1. _____	
2. _____	
3. _____	
The duties which acceptance of this post will involve are:	
(a) _____	
(b) _____	
(c) _____	
(d) _____	
<i>(Add specific duties if required)</i>	
If you agree to be considered for appointment as a Competent Person for the system(s), installation(s) and location(s) indicated above, and are willing to accept the appointment if offered, please complete Part 2 of this form and return it to me as soon as possible.	
Name of Proposer _____	
Authorised Person _____	
(On completion of Part 1, forward to the prospective Competent Person for completion of Part 2)	

Part 2: Personal details

(To be completed by the prospective Competent Person or on his/her behalf by the organisation by whom they are employed)

Name _____	
Current grade and job title _____	
Technical qualifications	
Details of apprenticeship	
Details of training received	
Courses	Dates
First-aid training for treatment of electric shock <input type="checkbox"/> Fire training <input type="checkbox"/>	
I confirm that I would be willing to accept the appointment as a Competent Person for the system(s), installation(s) and location(s) listed in Part 1 of this form	
Signed _____ Date _____	
Address _____ _____	
(On completion of Part 2, return this form to the nominating Authorised Person)	
Return address	

Part 3: Approval and scope of appointment

(To be completed by the Authorised Person)

<i>Name of Authorised Person</i>			
I hereby confirm that _____			
<ul style="list-style-type: none"> (i) is responsible to undertake work on the types of systems and equipment for which the appointment is sought; (ii) is familiar with the types of systems and equipment on which work is to be undertaken; (iii) possesses technical knowledge or sufficient experience to avoid danger that may be presented by the work to be undertaken; (iv) has an adequate knowledge of those parts of Health Technical Memorandum 06-03 – ‘Electrical safety guidance for high voltage systems’; (v) has adequate knowledge of, and within the last three years has received training in, first-aid treatment for electric shock; (vi) is suitable for appointment as a Competent Person to work in the vicinity of the following systems and equipment within the limitations identified below: 			
Systems and equipment	Locations as part 1 (Enter ✓)		
	1	2	3
Signed _____			
Date _____			
Address _____			

(On completion of part 3, send this form to the Authorising Engineer)			

Model letter for appointing or re-appointing a Competent Person

OFFER OF APPOINTMENT AS A COMPETENT PERSON

Dear _____ (*name of prospective Competent Person*)

As previously discussed, you are hereby offered an appointment as a Competent Person for the purposes of Health Technical Memorandum 06-03 – ‘Electrical safety guidance for high voltage systems’ for a period of one year, commencing on _____ (*date*).

Please note that the appointment offered covers only the locations and types of installation and equipment indicated on the certificate.

If you wish to accept the appointment, please acknowledge receipt of the enclosed certificate by signing and returning a copy of the attached letter.

Print name _____

Signature _____

(*Authorised Person*)

Copies to: Operational procedure manual

Model letter for accepting an appointment or re-appointment as Competent Person

ACCEPTANCE OF APPOINTMENT AS A COMPETENT PERSON

Dear _____ (*name of Authorised Person*)

I accept appointment as a Competent Person for the purposes of Health Technical Memorandum 06-03 – ‘Electrical safety guidance for high voltage systems’ for a period of one year commencing on _____ (*date*).

I note that the appointment covers only the locations and types of installation and equipment indicated on the certificate.

I will, so far as is reasonably practicable, ensure that I, and any others working with me or supervised by me, avoid danger to ourselves and others, and will not cause damage to electrical equipment.

I will not carry out any work beyond the limits as indicated on the certificate unless I am under the direct supervision of an Authorised Person so appointed.

Yours sincerely

(*Competent Person*)

Copies to: Operational procedure manual

Certificate of appointment as a Competent Person

Certificate of appointment as a Competent Person	
Certificate No. _____	
This is to certify that _____ (name of Competent Person) is appointed as a Competent Person for the following locations until the expiry date shown.	
1.	_____
2.	_____
3.	_____
<p>Duties:</p> <p>To accompany any non-Competent Person when entering a high voltage sub-station or enclosure for any purpose, except where that person is a Competent Person in possession of a valid limitation-of-access safety document and to remain within the building until the work is complete.</p> <p>To carry out maintenance tasks within the building as directed but not on high voltage equipment unless issued with a Permit-to-work by an Authorised Person.</p> <p>To trip the high voltage switchgear in case of emergency.</p> <p>Add specific duties if required:</p>	
<p>Signed _____ Authorised Person Name _____ Date _____</p> <p>Signed _____ Authorised Person Name _____ Date _____</p> <p>Signed _____ Authorised Person Name _____ Date _____</p> <p>(A copy of this certificate is to be placed in the operational procedure manual)</p>	

Appointment record

(To be completed by the Authorised Person)

This certificate is only valid until the last expiry date indicated below:

Issue	Issue date	Validity (years)	Expiry date	Signatures
First issue				
First renewal/ review				
Second renewal/ review				
Third renewal/ review				

Appendix 3 – Audit of safe system of work and safety procedures

General

- 1 This section details the audit and monitoring procedures to be carried out by the Designated Person, Authorising Engineers and Authorised Persons.

Validation audits by the Designated Person

- 2 The Designated Person is to arrange for a validation audit to be carried out one year after introduction of these procedures and then at intervals not exceeding five years.

Compliance audits by Authorising Engineers

- 3 Authorising Engineers are to carry out a compliance audit at each establishment for which they are appointed at a maximum of 12-monthly intervals.

Audit programme and progress reports

- 4 Authorising Engineers are to prepare a programme of audits covering a period of 12 months. The programme is to be prepared so that all significant installations for which they are appointed are seen over a maximum interval of three years. The programme is to be distributed to the Designated Person, the “focal point” Authorised Person and all other Authorised Persons at the establishment.

Compliance audits

- 5 The Authorising Engineer is to review the action plan and progress of any outstanding recommendations from the previous audit.
- 6 The Authorising Engineer is to examine the current and known future workload and is to assess whether sufficient Authorised Persons are appointed. The Authorising Engineer is also to examine the register of appointed Competent

Persons to ensure that sufficient persons are appointed.

Authorised person and documentation audit

- 7 The Authorising Engineer is to interview each Authorised Person to ascertain the quantity and quality of any safety documentation raised since the last audit. The Authorising Engineer is to carry out a full audit trail of at least one job carried out by each Authorised Person. This audit is to cover the job from start to completion. In the case of low activity, the Authorising Engineer is to look at all documents produced and to assess the Authorised Person against a hypothetical scenario.
- 8 The Authorising Engineer is to examine the job list to ensure that safety documentation has been used for all jobs requiring it.
- 9 The Authorising Engineer is to examine a representative sample of the documentation raised by each Authorised Person.
- 10 The Authorising Engineer is also to examine a representative sample of the support documentation (from the lockable document cabinet) for suitability.
- 11 The Authorising Engineer is to examine the training records and ensure that each person has maintained their qualification for the application of this Health Technical Memorandum, including emergency first-aid.

Safety equipment

- 13 The Authorising Engineer is to inspect a sample of the safety equipment to ensure that:
 - adequate equipment is available at the establishment;
 - it is suitable for the intended purpose;
 - it has been properly maintained; and

- the Authorised Persons, and other users, have been trained to use it safely.

Mimic diagram and system keys

- 13 This inspection is to include the working keys, the mimic diagram, key cabinet, and the duplicate key in the emergency “break glass” key box. The mimic is to show the current state of the HV system, the status of switchgear and the name of the Duty Authorised Person.

Substations and other installations

- 14 The Authorising Engineer is to examine a sample of electrical installations and substations and is to ensure that all installations are inspected at a maximum interval of three years.

Non-compliances

- 15 Where non-compliance is found, the Authorising Engineer is to take the following action:
- for non-compliances on completed jobs not adversely affecting the safety, investigate the reason and raise a non-compliance comment in the audit report;
 - for non-compliances on completed work that could have adversely affected the safety, investigate the reason and raise an auditor’s practice improvement notice;
 - for non-compliances on work-in-progress that may adversely affect safety, suspend the work, investigate the reason and raise an auditor’s suspension notice.

Audit report

- 16 The Authorising Engineer is to agree the factual findings with the focal point Authorised Person and other Authorised Persons before preparing the report. The report is to include compliant items, any non-compliant findings and a table of recommendations. The report is to be issued within 28 days of completion of the site visit.
- 17 Copies of the report are to be distributed to the Designated Person and the focal point Authorised Person, who is to arrange distribution to all other Authorised Persons.

Action plan

- 18 The focal point Authorised Person in consultation with the Authorising Engineer is to prepare an action plan to implement any recommendations from the report. The action plan is to be prepared within 28 days of receipt of the audit report and is to include the action to be taken, the name of the Authorised Person who will carry out the action, and the target date for completion. The Authorising Engineer is to copy the action plan to the Designated Person.

Short notice compliance audits by Authorising Engineers

- 19 In addition to the above procedures, the Authorising Engineer is to carry out one short-notice compliance audit of each Authorised Person every 12 months. This audit should be timed to coincide with work-in-progress if at all possible. The report of the findings is to be distributed to the individual Authorised Person and the Designated Person.

Compliance monitoring by Authorised Persons

- 20 Authorised Persons are to monitor work-in-progress regularly and are to keep a record of the findings and any remedial action initiated or required. Copies of the Authorised Persons’ reports are to be made available to the Authorising Engineer.

Auditing aids

- 21 The following generic checklists can be used as a guide for auditing the safe system of work for electrical distribution systems. Authorising Engineers can tailor these to suit the particular installation(s) for which they are appointed. Photographs may be included in the report where appropriate.

Authorising Engineer's audit checklist

Complete column 3 "Yes/No" to show state as found.

Tick column 4 only if action is required.

Authorised Persons

Authorised Person _____

		Y/N	Action
1.	Is the Authorised Person currently certificated?		
2.	Is the Authorised Person due for refresher training in HTM 06-03?		
3.	Is the Authorised Person due for training in emergency first-aid?		
4.	Is the Authorised Person due for training in use of cable tracing equipment?		
5.	Is the Authorised Person carrying out AP duties on a regular basis?		
6.	Is the Authorised Person carrying out monitoring of work-in-progress?		
7.	Are sufficient Authorised Persons appointed?		

Audit trail

Job number _____ Originating Authorised Person _____

8.	Does the safety programme follow the procedures in Table 1 or 2?		
9.	Is the safety programme clear, legible and unambiguous?		
10.	Was the safety programme countersigned by an appropriate person?		
11.	Does the Authorised Person have sufficient items of safety equipment to carry out the actions on the Safety programme?		
12.	Is the isolation and earthing diagram clear, legible and unambiguous?		
13.	Is the permit-to-work clear, legible and unambiguous?		
14.	Was the permit-to-work issued to a Competent Person?		
15.	Was the permit-to-work cancelled correctly?		
16.	Is the Sanction-for-test clear, legible and unambiguous?		
17.	Was the Sanction-for-test issued to a Competent Person?		
18.	Was the Sanction-for-test cancelled correctly?		
19.	Were the site records updated on completion of the work?		

Documentation

20.	Are the documents kept in the lockable documents cabinet?		
21.	Does the Authorised Person have access to a controlled copy of HTM 06-03?		
22.	Are the single line network diagrams of the electrical distribution correct and up-to-date?		
23.	Is the switchgear and transformer schedule correct and up-to-date?		
24.	Has the protection grading chart been checked?		
25.	Are the "as-laid" cable route drawings correct and up-to-date?		
26.	Are the "as-fitted" drawings correct and up-to-date?		
27.	Are copies of operation and maintenance manuals held for all equipment?		
28.	Are all events recorded in the logbook?		
29.	Are operational restrictions recorded in the logbook?		
30.	Is all of the distribution system included in the planned maintenance programme?		
31.	Is the register of Competent Persons up-to-date?		

Safety equipment		Y/N	Action
32.	Does the Authorised Person have sufficient safety locks, safety key boxes and multi-hasps for the likely number of concurrent jobs?		
33.	Does the Authorised Person have sufficient caution and danger signs for the likely number of concurrent jobs?		
34.	Are the potential indicator and proving unit satisfactory?		
35.	Is the earthing equipment inspected at annual intervals?		
36.	Is the other protective equipment inspected at annual intervals?		

Mimic diagram and system keys

37.	Does the mimic accurately reflect the current state of the system?		
38.	Is the name of the Duty Authorised Person shown on the mimic diagram?		
39.	Are the working keys held on marked key plates?		
40.	Are the arrangements for the “break glass” key box satisfactory?		
41.	Is a warning flag displayed on the mimic diagram for any operational restriction?		

Substations

<i>Substation externals</i>			
42.	Is there a safety sign (P1) displayed at the entrance?		
43.	Is the sign legible?		
44.	Is the name of the substation exactly the same as the switchgear schedule?		
45.	Is the sign securely fixed?		
46.	Is the correct contact telephone number shown?		

Substation security

47.	Is the door secure/sound?		
48.	Is there an emergency escape door?		
49.	If so, is it accessible and can it be opened from the inside?		
50.	Is there a clear escape route outside the substation?		
51.	Is there a 24-hour telephone point inside?		
52.	Are any non-AP items stored in the substation?		
53.	If so, are the access arrangements correctly controlled?		

Substation structure

54.	Is the substation dry and clean?		
55.	Are duct covers fully in place?		
56.	Are there any signs of rain ingress?		
57.	Are there any visible defects in the structure?		
58.	Are there any signs of rodents in the substation?		
59.	Is the working space and lighting adequate?		
60.	Is emergency lighting installed?		
61.	If so, is it included in the planned maintenance programme?		

Substation posters and labels

62.	Are posters displayed as required?		
63.	Is each item of switchgear clearly labelled?		
64.	Do the labels agree exactly with the switchgear schedule?		
65.	Are labels displayed at the rear of the switchgear?		

HV switchgear		Y/N	Action
66.	Is the switchgear operating mechanism locked?		
67.	Does the switchgear condition agree with the maintenance record?		
68.	Is there excessive noise or heat from the switchgear?		
69.	Are there any signs of leakage from visible compound-filled cable terminations?		
70.	Is the condition of the tripping battery installation satisfactory?		
71.	Are there any operational restrictions in place?		
72.	If so, are warning notices displayed?		

Fire precautions

73.	Is any rubbish or fire hazardous materials stored outside the substation?		
74.	Is a suitable fire extinguisher provided in the substation?		
75.	Has it been inspected?		
76.	Is there a “gas flooding” system installed?		
77.	If so, are there clear instructions displayed on how to inhibit the system when entering the substation?		

I confirm that, where actions are required, a report has been submitted to the Designated Person

Signature of AE

Appendix 4 – Mimic diagram and key locker

Mimic diagram

1. The mimic diagram should be:
 - (i) provided at the main high voltage substation/switchroom designated for the system;
 - (ii) in the form of a single line diagram indicating all high voltage circuits comprising the high voltage system, together with any low voltage interconnecting circuits that can back feed to the high voltage system (that is, generators, UPS systems etc);
 - (iii) fully equipped with switch, circuit breaker, transformer, generator, and UPS etc symbols complying with the requirements of BS EN 60617.

Note

This standard is now represented by the IEC database available from their website. See also Appendix 7 for typical symbols.

The switching equipment symbols should incorporate the facility to indicate whether the switch contacts are open, closed or earthed;

- (iv) an accurate representation of the system referred to in (ii) with all switching devices shown in their relative positions;
- (v) drawn to show all equipment and switching devices, clearly and correctly labelled;
- (vi) totally enclosed within a cabinet having full-width transparent doors complete with integral lock.

Keys

2. Complete sets of keys for each substation should be housed within the cabinet and should be labelled to correspond with the nomenclature used on the mimic diagram.
3. The cabinet should be equipped with “work on high voltage system in progress” and “Authorised Person on site” notices so arranged that they can only be displayed by an Authorised Person having a key to the key locker.
4. Where it is not practicable to keep in the mimic diagram cabinet all the documents specified in this Appendix, some of these documents may be kept in a lockable cabinet within the Authorised Person’s office.
5. The cabinet should incorporate a lower section, either desktop console or drop-down door arrangement, secured by an integral lock to accommodate the key locker, danger/caution notices, logbook, operational procedure manual, operating and maintenance manual, safety documents and the keys to all safety locks associated with the system.

Mimic diagram cabinet

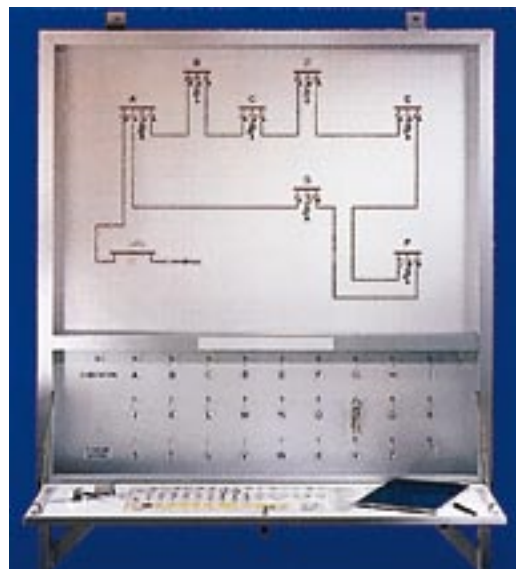

Appendix 5 – The Electricity Safety, Quality and Continuity Regulations 2002

The following is an extract from the Electricity Safety, Quality and Continuity Regulations 2002.

SCHEDULE 1

Regulations 11(c)(i) and 19(2)

DESIGN, COLOURS AND PROPORTIONS OF THE SAFETY SIGN

1. A safety sign shall incorporate a design, and shall be of the proportions, as shown in the diagram below, except that the height of the text may be increased to a maximum of $0.12 \times L$.
2. The triangle, symbol and text shall be shown in black on a yellow background.
3. The symbol shall not occupy more than 50 per cent of the area within the triangle.
4. A safety sign may include additional text but any such text
 - a. shall be in black; and
 - b. shall be the same size as the text used on the safety sign, and no part of any additional text shall appear on the sign higher than the base of the triangle.

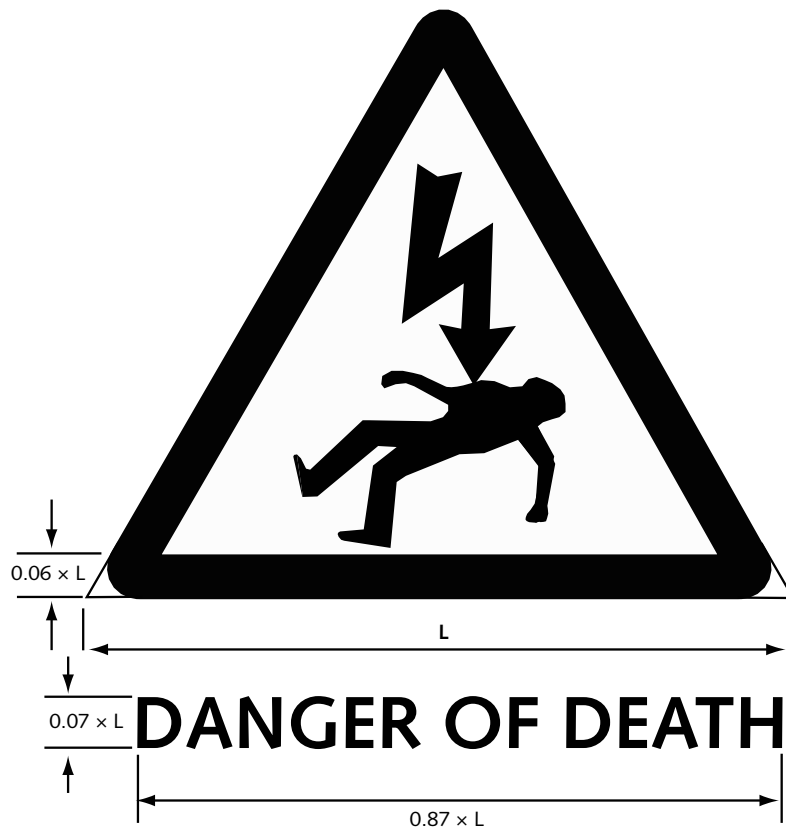

Appendix 6 – Typical single line diagram and switchgear and transformer schedules for a high voltage system

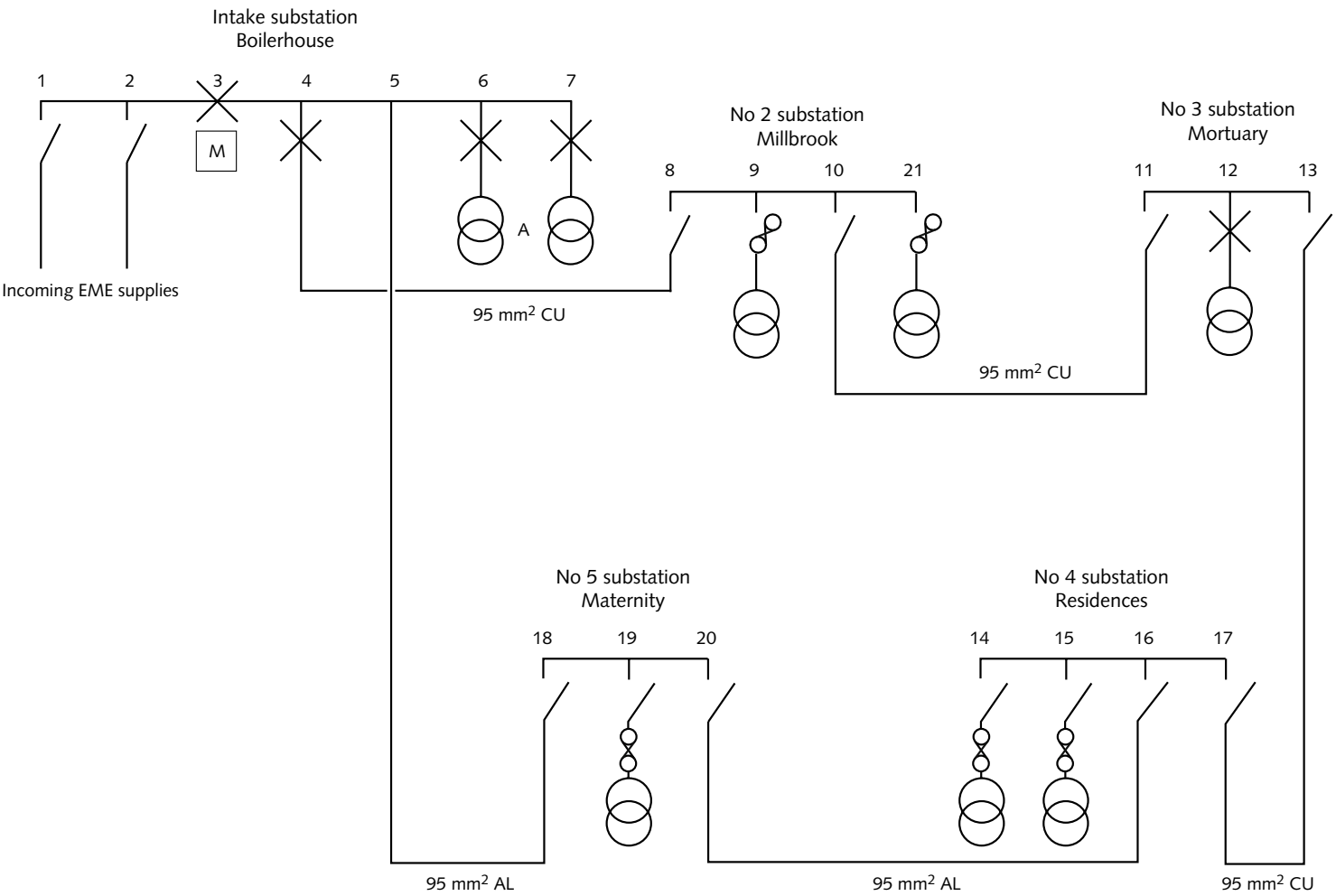

SUBSTATION	INTAKE SUBSTATION – BOILERHOUSE						
SWITCHGEAR NUMBER LABEL	1 FOX & GUDGEON 'T'	2 BURN HILL 'T'	3 BUS SECTION	4 MILBROOK SUB	5 MATERNITY SUB	6 TRANSFORMER NO.1	7 TRANSFORMER NO.2
SWITCHGEAR TYPE	OILSWITCH IL/2	OILSWITCH IL/2	OCB VSI12	OCB VSI12	OCB VSI12	OCB VSI12	OCB VSI12
OWNER/MAKER	BHDC/BRUSH	BHDC/BRUSH	BHDC/BRUSH	HH/BRUSH	HH/BRUSH	HH/BRUSH	HH/BRUSH
MAKERS SERIAL NO.	5/45352/1	5/45352/2	A/45352/3	A/45367/4	A/45367/5	A/45367/6	A/45367/7
RATINGS NORMAL BUS BARS	800A	800A	800A	800A	800A	800A	800A
RATINGS NORMAL SWITCH/OCB	400A	400A	400A	400A	400A	400A	400A
RATINGS FAULT 3 secs. WITHSTAND	350 mVA	350 mVA	350 mVA	350 mVA	350 mVA	350 mVA	350 mVA
TYPE OF CLOSING	MANUAL SPRING	MANUAL SPRING	MANUAL SPRING	MANUAL SPRING	MANUAL SPRING	MANUAL SPRING	MANUAL SPRING
TRIP COIL RATING			30V DC	30V DC	30V DC	2A AC	2A AC
RELAYS – FUNCTION & TYPE			IDMT	MCGG IDMT	MCGG IDMT	TLF	TLF
a) OVERCURRENT							
b) EARTH FAULT			IDMT	MCGG IDMT	MCGG IDMT		
c)				INSTANT. ON O/C	INSTANT. ON O/C		
d)				INSTANT. ON E/F	INSTANT. ON E/F		
PROTECTION SETTS. a) O/C PLUG SETT. & TMS			75% 0.3	1.25 0.1	1.25 0.1	12.5A	12.5A
b) E/F PLUG SETT. & TMS			30% 0.2	0.5 0.1	0.5 0.1		
c)				INF.	INF.		
d)				7	7		
INSTRUMENTS TYPE/SCALE RANGE			AMMETER 0–500A	AMMETER 0–200A	AMMETER 0–200A	AMMETER 0–50A	AMMETER 0–50A
CURRENT TRANSF.-No./VA/Class/P.amps			3 15/5P10 400/5	3 15/5P10 300/5	3 15/5P10 300/5	3 15/5P10 40/5	3 15/5P10 40/5
CABLE BOX ARRANGEMENT	REAR TRIF.	REAR TRIF.	REAR TRIF.	REAR TRIF.	REAR TRIF.	REAR TRIF.	REAR TRIF.
EARTHING ARRANGEMENT	INTEGRAL	INTEGRAL	INTEGRAL TRANSFER	INTEGRAL TRANSFER	INTEGRAL TRANSFER	INTEGRAL TRANSFER	INTEGRAL TRANSFER
MANUAL TRIP ARRANGEMENT			PUSH BUTTON	PUSH BUTTON	PUSH BUTTON	PUSH BUTTON	PUSH BUTTON
ADDITIONAL INFORMATION							
SITE SUPPLY DETAILS			SUBSIDIARY EQUIPMENT		TRANSFORMER		
D.N.O. DETAILS	R.G.H. DISTRIBUTION COMPANY		BRUSH OCB TEST PRODS.		KVA	500 kVA	500 kVA
SERVICE VOLTAGE	11000				VOLTAGE RATIO	11000/433	11000/433
FAULT LEVEL	88.3 mVA				VECTOR GROUP	Dyn11	Dyn11
MAX DEMAND					% IMPEDANCE	4.69	4.69
RESERVE CAPACITY					COOLING METHOD	ONAN	ONAN
R.E.C. PROTECTION TYPE	IDMT				TAPPINGS	±2½% & ±5%	±2½% & ±5%
PROTECTION SETTS. a) O/C PLUG SETT. & TMS	125% 0.3				TAP	3	3
b) E/F PLUG SETT. & TMS	20% 0.2				TOTAL WEIGHT	1747 Kg	1747 Kg
CT RATIO	400/5				OIL CAPACITY	433 Lts	433 Lts
					FITTINGS		
					LABEL		
					SERIAL NO.	KB317/1	KB317/2
					LOW VOLTAGE PROT.		
					SWITCHGEAR		
					CURRENT TRANS.		
					RELAY		
					SETTINGS		

SUBSTATION	NO. 2 SUBSTATION – MILLBROOK				NO. 3 SUBSTATION – MORTUARY		
SWITCHGEAR NUMBER	8	9	10	21	11	12	13
LABEL	INTAKE SUBSTATION	TRANSFORMER No.1	MORTUARY SUB	TRANSFORMER No.2	MILLBROOK SUB	TRANSFORMER No.1	RESIDENCES SUB
SWITCHGEAR TYPE	OIL SWITCH J4	FUSE SWITCH GF3	OIL SWITCH J4	FUSE SWITCH GF3	Merlin Gerin Ringmaster RN2c-T1/21 SF6 Ring Main unit		
MANUFACTURER	LONG & CRAWFORD	LONG & CRAWFORD	LONG & CRAWFORD	LONG & CRAWFORD	Schneider Electric Ltd.		
MANUFACTURER'S SERIAL NO.	J4 850625	GF3 850107	J4 850626	GF3 891956	SR3L02224		
RATINGS NORMAL BUS BARS	800A	800A	800A	800A	630A		
RATINGS NORMAL SWITCH/FUSE SWITCH	630A	200A	630A	200A	630A	200A	630A
RATINGS FAULT 3 secs. WITHSTAND	350 mVA	350 MVA	350 MVA	350 MVA	16 kA 3 secs.	3.15 kA	16 kA 3 secs.
TYPE OF CLOSING	MANUAL SPRING	MANUAL SPRING	MANUAL SPRING	MANUAL SPRING	Independent Manual		
HRC FUSE RATING		50A		36A	5A TLF		
CABLE BOX ARRANGEMENT	REAR TRIF.	REAR TRIF.	REAR TRIF.	REAR TRIF.	Left Side Down	Rear Down	Right Side Down
EARTHING ARRANGEMENT	INTEGRAL	INTEGRAL	INTEGRAL	INTEGRAL	INTEGRAL		
MANUAL TRIP ARRANGEMENT		MAIN HANDLE		MAIN HANDLE	MAIN HANDLE		
ADDITIONAL INFORMATION		CABLE TEST FACILITY		CABLE TEST FACILITY	CT's connected at 100/5		
TRANSFORMERS							
LABEL		TRANSFORMER No.1		TRANSFORMER No.2		TRANSFORMER No.1	
MANUFACTURER		BRUSH		SOUTH WALES		BRUSH	
KVA		500 kVA		315 kVA		500 kVA	
VOLTAGE RATIO		11000/433		11000/433		11000/433	
VECTOR GROUP		Dyn11		Dyn11		Dyn 11	
% IMPEDANCE		4.66		4.49		4.67	
COOLING METHOD		ONAN		ONAN		LNAN	
TAPPINGS		±2½% & ±5%		±2½% & ±5%		±2½% ±5½%	
TAP		3		2		2	
TOTAL WEIGHT		1747 kg		1930 kg		1747 kg	
OIL CAPACITY		433 Litres		415 Litres		433 Litres	
FITTINGS						No drain plug	
SERIAL NO.		68298/1		112709		69317/2	
LOW VOLTAGE PROTECTION							
SWITCHGEAR							
CURRENT TRANSFORMERS							
RELAY							
SETTINGS a) O/C PLUG SETT. & TMS							
b) E/F PLUG SETT. & TMS							
SUBSIDIARY EQUIPMENT	TEST PRODS FOR FUSE SWITCH						

Grading charts

Overcurrent

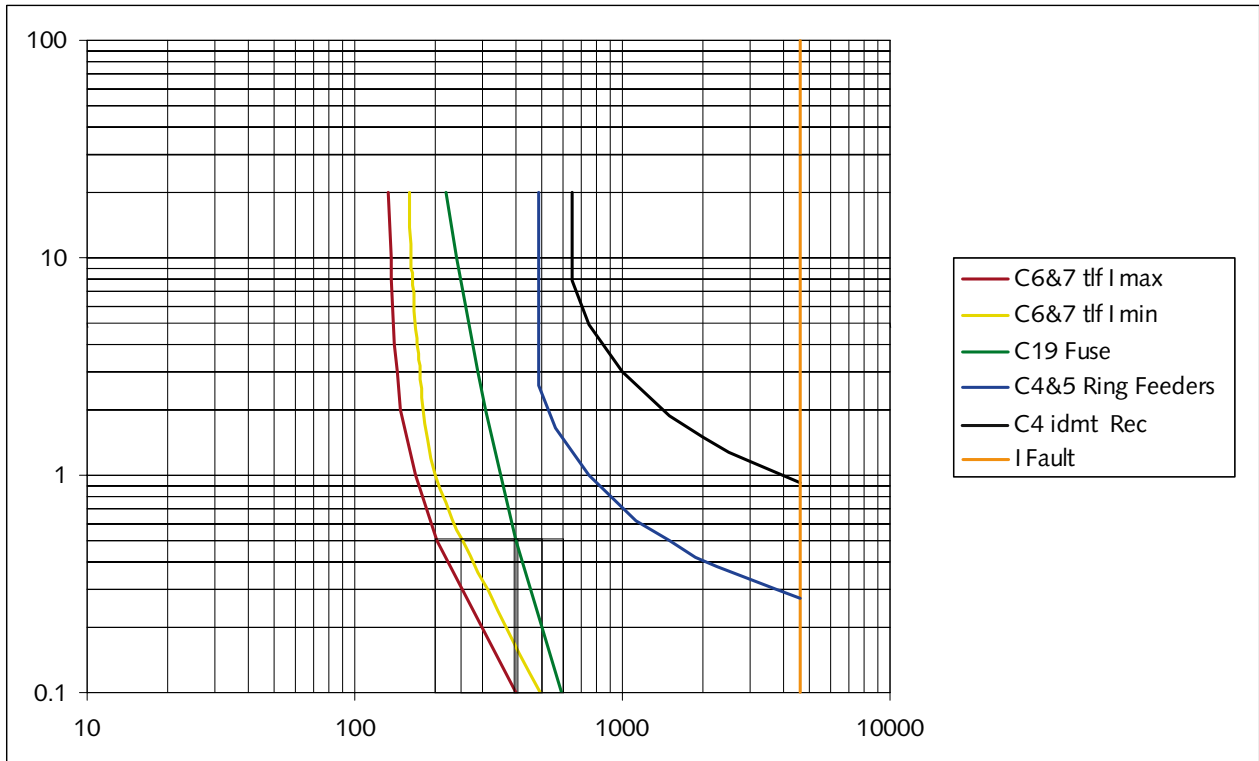

Earth fault

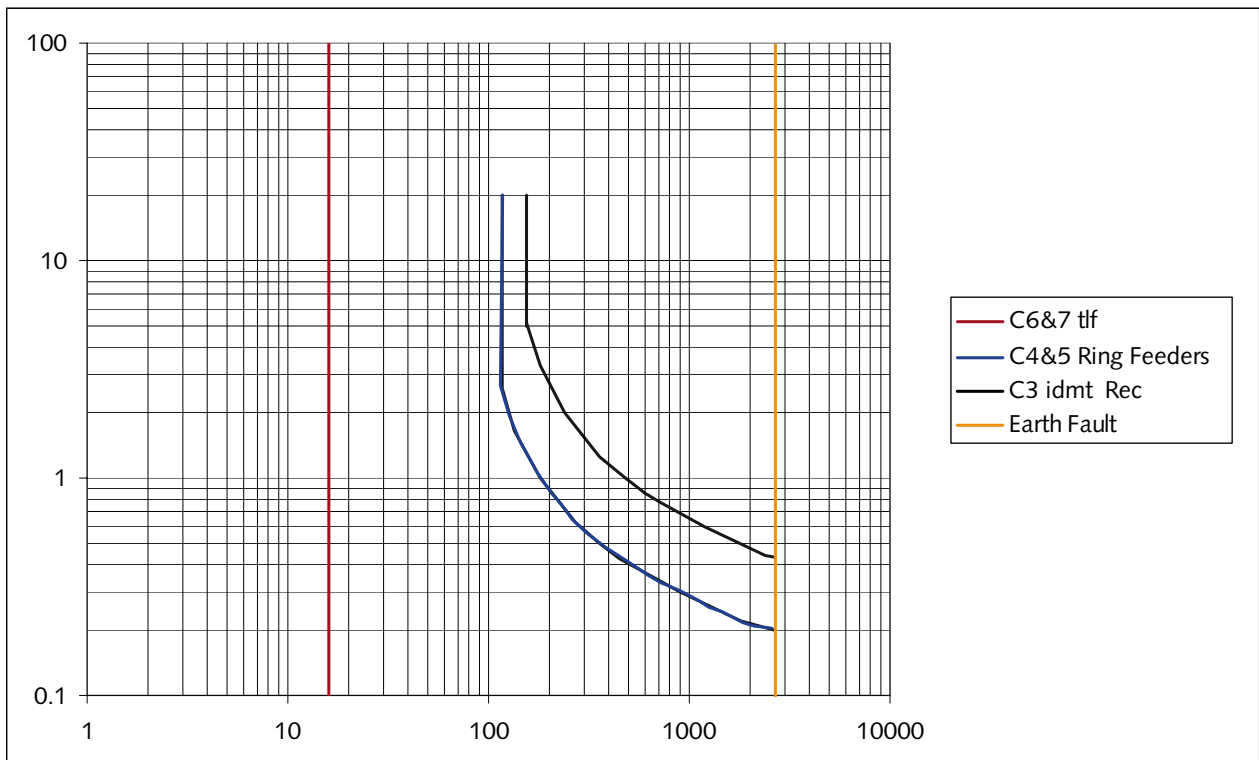

Appendix 7 – Standard symbols for isolation and earthing diagram

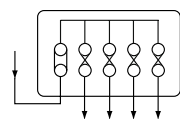
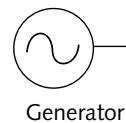
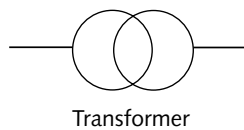
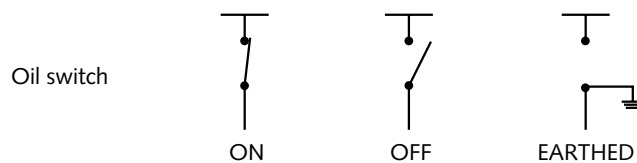
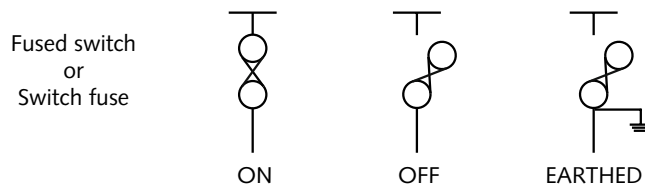
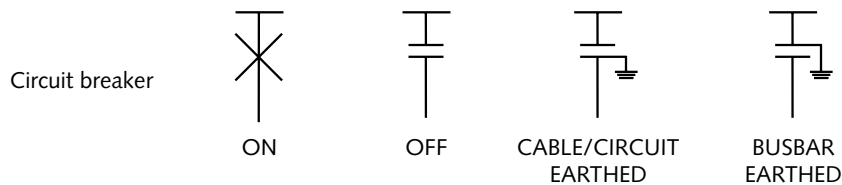

Feeder pillar:
general symbol

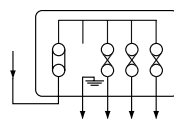

Feeder pillar:
outgoing way,
isolated and earthed

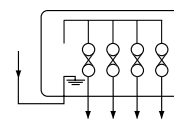

Feeder pillar:
incoming way,
isolated and earthed

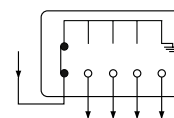
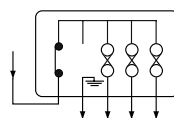
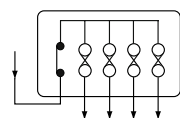

IP2X disconnector type feeder pillars

Switchgear

The terminology used to describe a piece of switchgear on a system should state:

- where** the switchgear is located;
- what type** of switchgear is going to be operated;
- to where** does the switchgear connect.

(See Figure A2)

Figure A2 Switchgear network diagram

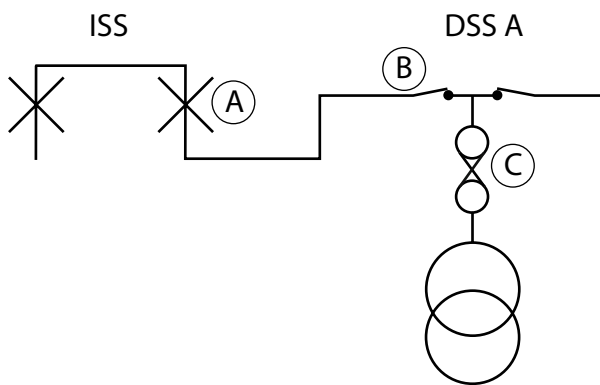

	Where	What	To where
A	ISS	OCB	To DSS A
B	DSS A	Oil switch	To ISS
C	DSS A	Fuse switch	To transformer

Operation

The operation of the switchgear should be recorded as follows:

Switches/fused units

Switch to on
Switch to off
Switch to earth

Circuit breakers

Switch to on

Appendix 8 – Poster

Extracts from Health Technical Memorandum 06-03 Safety Guidance

General

Guidance in this Health Technical Memorandum applies to all healthcare facilities containing a high voltage system.

Guidance is intended to assist Duty Holders to meet the requirements of the Electricity at Work Regulations 1989 ("the Regulations"), which are made under the Health and Safety at Work etc Act 1974 (HSW Act 1974). It is not an authoritative interpretation of the regulations or other laws. Only the courts can make such interpretation.

Inadequate control and/or improper use of electricity is a danger to life and property. Owners, occupiers, general managers/chief executives and those responsible for electrical services as "Duty Holders" are accountable for ensuring control; they are also responsible for the safe management, design, installation, operation and maintenance of the electrical systems.

Purpose

The provision of effective procedures and their formalising into written instructions is essential for ensuring a safe system of working where this involves work on conductors or equipment of high voltage systems. This document makes recommendations for the allocation of duties to personnel and the manner in which these duties should be performed.

High voltage systems associated with healthcare and social services premises vary considerably in size and complexity. The procedures advocated in this document therefore cannot cover every circumstance and consequently may, in specific instances, need to be supplemented by local written procedures. These local arrangements should only be considered when, in the opinion of the Authorising Engineer (HV), the guidance given in this document is inadequate for the particular circumstances. Any such supplementary procedures must therefore maintain the same standards of electrical safety outlined in this guidance.

Because of the specialist nature of the risks, it is important that a carefully prepared procedure exists for dealing with the routine servicing of high voltage installations and with any emergencies that arise.

Objections

When any person receives instructions regarding the operation of, or work on, the high voltage system and associated electrical equipment at the managed premises, they should report any objections (on safety grounds) to the carrying out of such instructions to the persons issuing them, who should then have the matter investigated and, if necessary, referred to a more senior level for a decision before proceeding.

Definition of personnel

Authorising Engineer (HV)

An Authorising Engineer (HV) is appointed in writing by the Designated Person to take responsibility for the effective management of this safety guidance (HV). The person appointed should possess the necessary degree of independence from local management to take action within this guidance.

Authorised Person (HV)

An Authorised Person (HV) is appointed in writing by an Authorising Engineer (HV) in accordance with this safety guidance (HV) and is responsible for the implementation and operation of this guidance with regard to work on, or the testing of, defined electrical equipment.

Competent Person (HV)

A Competent Person (HV) is approved and appointed in writing by the Duty Authorised Person (HV) for defined work, possessing the necessary technical knowledge, skill and experience relevant to the nature of the work to be undertaken, who is able to prevent danger or, where appropriate, injury and who is able to accept a safety document from the Duty Authorised Person (HV).

Safety documents

Permit-to-work

A written authority issued by the Duty Authorised Person for work to be undertaken on electrical equipment.

Sanction-for-test

A written authority issued by the Duty Authorised Person for testing to be undertaken on electrical equipment.

Limitation-of-access

A written authority issued by the Duty Authorised Person for specified tasks to be undertaken in an area or location which is under the control of the Authorised Persons for electrical safety reasons, and for which a permit-to-work or sanction-for-test are not appropriate.

Security and admittance to substations

All access doors to each substation, switchroom and enclosure containing high voltage electrical equipment must be kept securely locked when unattended.

No person other than an Authorised Person (HV) or Competent Person (HV) may enter a room containing high voltage equipment unless they are accompanied by an Authorised Person (HV) or have receipt of a permit-to-work, sanction-for-test or limitation-of-access issued by an Authorised Person (HV).

When the substation is provided with "automatically controlled fire protection", the person must be trained for entry into such room.

Operation of high voltage switchgear

The following points apply:

- high voltage switching should be carried out by the Duty Authorised Person (HV) or by persons acting under his/her personal supervision, except when necessary to isolate in an emergency when a Competent Person (HV) will have access to substations in which emergency tripping facilities are available. That person, without delay and with some urgency, must advise the Duty Authorised Person of the action

taken. These circuit breakers will be fitted with locks preventing unauthorised reclosure. The Authorised Person (HV) should be informed of all high voltage emergency switching;

- locks should be applied as necessary to prevent unauthorised operation of switchgear (except emergency tripping as referred to above);
- oil circuit breakers (OCBs) should in general be reclosed a maximum of two times after opening under fault conditions. The equipment should be inspected at the first opportunity after opening under fault conditions;
- when switchgear shows any sign of defect or malfunction after operating, its condition should be reported immediately to the Authorising Engineer (HV), and it should be examined before further operation;
- no high voltage earthing switch should be operated or circuit main earth connection attached or removed except by an Authorised Person (HV);
- making live or dead by visual signal, or by prearranged understanding after an agreed interval of time, is not an acceptable practice.

Health Technical Memorandum 06-03 does not apply where equipment has been isolated, discharged, disconnected and removed from the system or installation.

Equipment that is considered by an Authorised Person (HV) to be in a dangerous condition should be isolated elsewhere and action taken to prevent it from being reconnected to the electricity supply.

All working on, or testing of, high voltage equipment connected to a system should be authorised by a permit-to-work or a sanction-for-test following the procedures set out in Tables 1 and 2.

No hand or tool (unless the tool has been designed for the purpose) must make contact with any high voltage conductor unless that conductor has been confirmed dead by an Authorised Person (HV) in the presence of the Competent Person (HV).

Where any work or test requires an Accompanying Safety Person (HV) to be present, he/she should be appointed before that work or testing can begin.

Voltage test indicators should be tested immediately before and after use against a test supply designed for the purpose.

Where the procedures involve the application of circuit main earths, the unauthorised removal of such earths should be prevented, wherever practicable, by the application of safety locks.

Role and duties of the Competent Person (HV)

Competent Persons (HV) should comply with Health Technical Memorandum 06-03 when carrying out work, whether instructions are issued orally or in writing.

Competent Persons (HV) should use safe methods of work, safe means of access and the personal protective equipment and clothing provided for their safety.

Competent Persons, when recipients of a safety document, should:

- be fully conversant with the nature and the extent of the work to be done;
- read the contents and confirm to the person issuing the safety document that they are fully understood;
- during the course of the work, adhere to, and instruct others under their charge to adhere to, any conditions, instructions or limits specified on the safety document;
- keep the safety document and (where appropriate) keys in safe custody, and correctly implement any management procedure to achieve this;
- when in charge of work, provide immediate or personal supervision as required;
- warn all persons as quickly as possible to withdraw from, and not to work on, the equipment concerned until further notice if, during the course of work, a hazard which could result in danger arises or is suspected. The situation should be reported immediately by the Competent Person (HV) to an Authorised Person (HV).

Competent Persons (HV) should not start or restart work under a safety document issued to another Competent Person (HV).

Having accepted a safety document, the Competent Person (HV) may only undertake or supervise the work or test specified until the task is complete and the Competent Person (HV) has signed part 3 of the permit or sanction-for-test, which is retained in the pad. Neither the Competent Person nor any person under the direct control of the Competent Person (HV) is to attempt to undertake any other duties.

Unless it is unavoidable, the Competent Person (HV) is not to leave the location of the work or test until the task is completed. If the Competent Person (HV) has to temporarily leave the location of the work or test, the task should be suspended, and adequate safety precautions taken to prevent danger. The work or test is not to be resumed until the Competent Person (HV) has returned to the location of the work or test.

Competent Persons (HV) clearing a safety document should do so only after all persons working under the safety document have been withdrawn from, and warned not to work on, the equipment concerned. Where appropriate, they should ensure that all tools, gear and loose material have been removed, guards and access doors replaced and the workplace left tidy.

Table 1 Procedures to be carried out by an Authorised Person (HV) to enable work on high voltage equipment

Steps ¹	Procedure
1 Prepare a safety programme	(i) Prepare a safety programme plus an isolation and earthing diagram in duplicate, and obtain countersignatures from another Authorised Person (HV). (ii) Before any work can begin, obtain permission from the manager in charge of the area to be affected by the work. (iii) Sign on as the Duty Authorised Person (HV), and place notices in mimic.
2 Isolate and fix signs	(i) Isolate from all sources of supply. (ii) Prevent unauthorised connection by fixing safety locks and caution signs at points-of-isolation. (iii) Fix danger signs on live equipment adjacent to the point-of-work.
3 Prove dead	(i) Prove dead with a high voltage potential indicator at all accessible points-of-isolation. (ii) Where appropriate, prove dead on the low voltage side of a transformer, that is LV feed pillars, LV distribution boards etc.
4 Earth	(i) Earth conductors at all points-of-isolation and fix safety locks to earths. (ii) Identify with certainty or spike underground cables at the point/s of work if the conductors are to be cut or exposed. Earth overhead lines near the working places. (iii) Earth overhead lines near the working places.
5 Issue the permit-to-work	(i) The Competent Person (HV) is to be shown the safety arrangements at all the point/s of isolation and at the locations of the work, and is to initial the isolation and earthing diagram. (ii) Mark the point-of-work. (iii) Issue the permit-to-work, isolation and earthing diagram, and the key to the safety key box to the Competent Person (HV). (iv) Adjust mimic diagram and complete the site logbook.
6 Undertake the work	The Competent Person (HV) is to undertake or directly supervise the work and on completion, or when the work is stopped and made safe, is to return the original of the permit-to-work, the isolation and earthing diagram and the Competent Person's (HV) key to the safety key box to the Duty Authorised Person (HV), and complete part 3 of the permit retained in the pad.
7 Check the equipment	If the work has been completed, check to ensure it is safe to energise. If the work has been stopped, check the equipment has been made safe.
8 Cancel the permit-to-work	(i) Cancel the permit-to-work by signing part 4 and by destroying the permit in the presence of the Competent Person (HV). (ii) File the isolation and earthing diagram in the operational procedure manual. (iii) Return key to key safe.
9 Restore to operational state	(i) If the equipment requires testing, follow the procedure in Table 2. (ii) Remove safety locks and earths applied in step 4. (iii) Remove safety locks and signs applied in step 2. (iv) Restore equipment to an operational state. (v) Adjust mimic and complete site logbook.

Notes:

¹ The Authorised Person (HV) is responsible for all tasks.

Table 2 Procedures to be carried out by an Authorised Person (HV) to enable testing on high voltage equipment

Steps ¹	Procedure
1 Prepare a safety programme	(i) Prepare a safety programme plus an isolation and earthing diagram in duplicate, and obtain countersignatures from another Authorised Person (HV). (ii) Before any test can begin, obtain permission from the manager in charge of the area to be affected by the test. (iii) Sign on as the Duty Authorised Person (HV), and place notices in mimic.
2 Isolate and fix signs	(i) Isolate from all sources of supply. (ii) Prevent unauthorised connection by fixing safety locks and caution signs at points-of-isolation. (iii) Fix danger signs on live equipment adjacent to the point of the test. (iv) If a high voltage enclosure is needed, set up barriers and fix danger signs.
3 Prove dead	(i) Prove dead with a high voltage potential indicator at all accessible points-of-isolation. (ii) Where appropriate, prove dead on the low voltage side of the transformer, that is LV feed pillars, LV distribution boards etc.
4 Earth	(i) Earth conductors at all points-of-isolation. (ii) Fix working locks to earths to enable their removal when required. (iii) Identify with certainty or spike underground cables at the point of test and at the distant end. (iv) Earth overhead lines near the point of test.
5 Issue the sanction-for-test	(i) The Competent Person (HV) is to be shown the safety arrangements at all the point/s of isolation and at the locations of the test, and is to initial the isolation and earthing diagram. (ii) Issue the sanction-for-test, isolation and earthing diagram, and the key to the safety key box to the Competent Person (HV). (iii) Retain working lock keys, and remove and replace earths as requested.
6 Undertake the test	The Competent Person (HV) is to undertake or directly supervise the test. On satisfactory completion of the test, or when the test is stopped and made safe, the conductors should be discharged and any earths restored. The Competent Person (HV) should return the original of the sanction-for-test and the key to the safety key box to the Duty Authorised Person (HV), and complete part 3 of the sanction retained in the pad.
7 Check the equipment	If the test has been completed, check to ensure it is safe to energise. If the test has been stopped, check the equipment has been made safe.
8 Cancel the sanction-for-test	(i) Cancel the sanction-for-test by signing part 4 and by destroying the sanction in the presence of the Competent Person (HV). (ii) File the isolation and earthing diagram in the operational procedure manual. (iii) Return key to key safe.
9 Restore to operational state	(i) Remove safety locks and earths applied in step 4. (ii) Remove safety locks and signs applied in step 2. (iii) Restore equipment to an operational state. (iv) Adjust mimic and complete site logbook.

Notes:

¹ The Authorised Person (HV) is responsible for all tasks.

Appendix 9 – Qualifications and training requirements

Qualifications of an Authorising Engineer

1. To be eligible for appointment, a prospective Authorising Engineer should:
 - a. be a chartered or an incorporated engineer with practical and relevant technical engineering experience of the types of system and equipment relative to their appointment;
 - b. have satisfactorily completed an approved Authorised Person initial training course in the last three years or within six months of a first-time nomination;
 - c. have satisfactorily completed an approved Authorising Engineer training course in the last three years or within six months of a first-time nomination;
 - d. be familiar with the different types of equipment, installation and system in use within the area for which appointment is sought;
 - e. have a basic knowledge of the systems and installations in use in the area for which they will become responsible, and become familiar with the more complex systems;
 - f. preferably be independent from the organisation – this is important to exercise the duties of the post;
 - g. be able to demonstrate their competency and suitability for the role by demonstrating a good understanding of the management tasks involved and knowledge of Health Technical Memorandum 06-03 – ‘Electrical safety guidance for high voltage systems’ prior to appointment;
 - h. have adequate knowledge of, and within the last three years have successfully completed a training course on, emergency first-aid.

Authorising Engineer (LV) initial training

2. This guidance suggests that, in order to become eligible for appointment as an Authorising Engineer, candidates should have successfully completed an appropriate training course for Authorised Persons. The course profile is described in this Appendix.

Qualifications of Authorised Persons (LV)

3. Prospective Authorised Persons should be nominated by the management and assessed by the Authorising Engineer. The appointment is to be for defined systems and installations and will be registered on a certificate of appointment signed by the Authorised Person and the Authorising Engineer.
4. To be eligible for appointment as an Authorised Person, the prospective Authorised Person should:
 - a. be over 23 years of age;
 - b. be electrically qualified within the following range:
 - (i) degree;
 - (ii) HND/HNC;
 - (iii) OND/ONC;
 - (iv) BTech 4 or 3;
 - (v) C&G;
 - (vi) NVQ at level III or above;
 - c. have an adequate knowledge of this guidance and of those regulations that are applicable to the systems and installations for which the appointment is sought;
 - d. be technically competent and qualified to safely operate, and make safe to work on or test, the equipment, systems or installations for which appointment is sought;

- e. be familiar with the equipment, systems or installations for which appointment is sought;
- f. have successfully completed an Authorised Persons (HV) training course approved by the Authorising Engineer;
- g. before being appointed, be able to demonstrate competency and suitability for the role through a formal interview carried out by the Authorising Engineer;
- h. have adequate knowledge of, and within the last three years have successfully completed, an emergency first-aid training course.

Authorised Person (HV) initial training

- 5. This guidance suggests that, in order to become eligible for appointment as Authorised Persons, candidates should have successfully completed an approved initial training course for Authorised Persons. The course profile is described in this Appendix. There are also periods of on-site training and familiarisation that are described in paragraph 10 of this Appendix.

Refresher training

- 6. This guidance suggests that an Authorising Engineer should attend an appropriate Authorised Persons' training course at intervals not exceeding five years.
- 7. This guidance suggests that an Authorising Engineer should attend an appropriate Authorising Engineer refresher training course at intervals not exceeding five years.
- 8. This guidance suggests that an Authorised Person should attend an appropriate training course for Authorised Persons at intervals not exceeding three years.
- 9. Refresher training courses should cover the same subject areas as the corresponding initial training courses. For Authorised Persons, the courses should be biased towards the practical aspects of the duties. Refresher training courses are generally expected to have a duration of about half that of the corresponding initial training course.
- 10. Re-attendance on an initial training course as a means of refresher training may be appropriate, for instance, where Authorised Persons have had little or no practical experience in recent years, or where over-familiarity with Authorised Person duties may

have led to departures from standard safety procedures.

- 11. The Authorising Engineer is responsible for deciding when training is necessary for individual Authorised Persons, and normally every Authorised Person should attend training every three years. However, the Authorising Engineer may consider extending this period up to a maximum of five years. In support of this decision, copies of the reasons and the approval given are to be held on file by the Authorising Engineer. Under no circumstances can the training period be extended beyond five years.

Familiarisation training

- 12. At the end of the familiarisation period for the systems, installations and equipment for which the appointment is sought, the prospective Authorised Person should be able to demonstrate:
 - a. a good working knowledge of the procedures associated with the operation of this guidance, the role and duties of an Authorised Person and any agreed local variation;
 - b. a good working knowledge of the layout of the electrical distribution, the location of the mimic diagram, safety key boxes, working key cabinet and how to gain access to them;
 - c. a good working knowledge of the operation – under normal, failure and fault conditions – of all the principal components of the systems and installations for which authorisation is being sought, such as switchgear, distribution equipment and standby generating sets;
 - d. practical experience, under the direct supervision of an experienced Authorised Person, of the operation of the electrical equipment forming part of the system or installation;
 - e. knowledge of the location of, how to obtain access to, and the use of, all appropriate protective equipment, test indicators (including appropriate test supplies (proving units)), where applicable low voltage potential indicators (including appropriate test supplies (proving units)), earthing equipment and safety signs;
 - f. a good understanding of all the necessary safety measures to be taken to prevent danger or, where appropriate, injury, and to prevent damage to equipment;

- g. knowledge of any necessary liaison with the local facilities managers, Authorised Persons of other disciplines, electricity supply authorities, and contractors having operation, repair or maintenance contracts.

On-site training

13. On-site training is to consist of putting into practice, under the supervision of an experienced Authorised Person, the knowledge gained during the familiarisation period. During this period, the prospective Authorised Person is to keep a record of each event attended in the Authorised Person's logbook detailing the actions taken both personally and by the Authorised Person. This logbook should be produced at the interview with the Authorising Engineer or a qualified nominated representative.

Approved courses

14. Management have a general duty to ensure that their employees receive training necessary to allow them to safely perform their duties.
15. Appropriate training courses are formal courses of instruction appropriate to the duties expected to be performed by a prospective or practising Authorising Engineer, Authorised Persons or Competent Persons, which have been approved for the purpose by the management.
16. Such courses are to be designed to impart an adequate level of knowledge of this guidance and of other matters necessary for the application of safe systems of work. In addition, they are to include practical experience of applying safe working procedures on a range of typical high voltage equipment arranged to provide simulated circuits.
17. Students should be continually assessed in both written and practical exercises so that, on completion of the course, the training organisation can make an independent assessment of their suitability and technical competence for consideration by the Authorising Engineer. The students should also be informed directly of the results of the assessments.
18. Suitable course profiles for this purpose are included in this Appendix. These are for general guidance only, and courses that are a composite of existing commercially-run courses may be acceptable provided the Authorising Engineer has given approval.

Initial training course for an Authorising Engineer (HV)

19. Approved training courses for an Authorising Engineer are to provide the necessary training and background information to prepare candidates to safely discharge the duties of an Authorising Engineer in accordance with this guidance.
20. The basic training is to ensure that:
 - a. the management policy towards electrical safety is applied universally across the areas of management responsibility;
 - b. Authorised Persons are correctly selected and appointed, and their application of Health Technical Memorandum 06-03 – 'Electrical safety guidance for high voltage systems' is properly audited;
 - c. the roles and duties of an Authorising Engineer with regard to the selection of Authorised Persons are looked at in detail;
 - d. the procedures to be adopted when work is undertaken are carried out in a controlled environment.
21. The course should have a duration of about three days, and the scope is to include:
 - a. an introduction to the safe systems of work;
 - b. the roles and responsibilities of persons for this system;
 - c. practical and procedural aspects of safe working practices;
 - d. nomination, evaluation, appointment and auditing of Authorised Persons;
 - e. candidate interview techniques;
 - f. training requirements for new and in-service Authorised Persons;
 - g. termination procedures for Authorised Persons;
 - h. focal point duties, including accident investigation.

Training course profile for Authorised Person (HV) initial training

22. Approved training courses for high voltage ring and radial distribution systems are to provide the necessary basic training and background information to prepare students to safely discharge the duties, in accordance with Health Technical

Memorandum 06-03 – ‘Electrical safety guidance for high voltage systems’, as an Authorised Person in respect of the defined distribution systems.

23. The basic training is to provide:
- an adequate knowledge of the reasoning and content of Health Technical Memorandum 06-02 – ‘Electrical safety guidance for low voltage systems’;
 - a thorough knowledge of, and practical experience in, the duties and responsibilities of an Authorised Person (Electrical);
 - an introduction to the theory, application, operation and maintenance of components of typical high voltage ring and radial distribution systems.
24. The background information is to provide an understanding of the principles involved in the design, operation and maintenance of typical high voltage distribution systems and their associated protective devices.
25. The course should last about ten days, and the scope is to include:
- statutory requirements relating to electrical safety;
 - Health Technical Memorandum 06-03 – ‘Electrical safety guidance for high voltage systems’;
 - role and duties of the Authorised Person;
 - types and functions of common high voltage distribution switchgear;
 - voltage distribution equipment, including transformers and cables;
 - operation of high voltage ring and radial distribution systems;
 - protective devices, including relays, fuses and interlocks;
 - operation and maintenance procedures for high voltage distribution equipment;
 - operation and maintenance procedures for stand-by power supplies and equipment;
 - practical exercises on switching simulated high voltage ring and radial distribution systems;
 - practical exercises on making high voltage equipment safe to work on or test, including:

- procedures pertaining to permits-to-work and sanctions-for-test;
- cable detection, location and identification.

Training course profile for Authorised Person refresher training

26. For Authorised Persons (HV), approved refresher training courses are biased towards high voltage distribution systems.
27. The basic training should provide:
- an update of the student’s knowledge of the reasoning and content of Health Technical Memorandum 06-03;
 - a reinforcement of the student’s knowledge of, and practical experience in, the duties and responsibilities of an Authorised Person (Electrical).
28. The course last about five days, and the scope is to include the more practical application of:
- statutory requirements relating to electrical safety;
 - Health Technical Memorandum 06-03;
 - Authorised Person (Electrical) role and duties;
 - types and functions of common high voltage distribution switchgear;
 - types and functions of other common high voltage distribution equipment, including transformers and cables;
 - operation of high voltage ring and radial distribution systems;
 - protective devices, including relays, fuses and interlocks;
 - operation and maintenance procedures for high voltage distribution equipment;
 - operation and maintenance procedures for stand-by power supplies and equipment;
 - practical exercises on switching simulated high voltage ring and radial distribution systems;
 - practical exercises on making high voltage equipment safe to work on or test, including:
 - procedures pertaining to permits-to-work and sanctions-for-test;

- (ii) cable detection, location and identification.

Emergency first-aid training and equipment

- 29. Training in emergency first-aid is to be provided by organisations whose training and qualifications for first-aiders are approved by the Health and Safety Executive for the purposes of the Health and Safety (First-Aid) Regulations 1981.
- 30. Training courses are to be of at least four hours' contact time, and should include the following subjects:
 - a. resuscitation (as appropriate for the treatment of electric shock);
 - b. treatment of burns;
 - c. control of bleeding;
 - d. treatment of the unconscious casualty;
 - e. contents of first-aid box;
 - f. communication.
- 31. This training is to be repeated, as a minimum, every three years.
- 32. Copies of certificates issued to Authorised Persons are to be held by the Authorising Engineer.
- 33. Copies of the certificates issued by first-aid trainers for Competent Persons and Accompanying Safety Persons are to be held in the operational procedure manual.
- 34. A current list of first-aiders for the appropriate locations, including, where appropriate, their telephone numbers, is to be held in the operational procedure manual.

Contractors' staff

- 35. All contractors' staff working on or testing electrical installations, systems and equipment for which the management has control of the electrical danger are to receive, as a minimum, the emergency first-aid training indicated above.
- 36. Copies of the certificates issued by first-aid trainers for contractors' Competent Persons and Accompanying Safety Persons are to be held in the operational procedure manual.

References

Acts and regulations

Confined Spaces Regulations 1997. SI 1997 No 1713. HMSO, 1997.

<http://www.opsi.gov.uk/si/si1997/19971713.htm>

Construction (Design and Management) Regulations 1994. SI 1994 No 3140. HMSO, 1995.

http://www.opsi.gov.uk/si/si1994/Uksi_19943140_en_1.htm

Construction (Design and Management) (Amendment) Regulations 2000. SI 2000 No 2380. HMSO, 2000.

<http://www.opsi.gov.uk/si/si2000/20002380.htm>

Electricity at Work Regulations 1989. SI 1989 No 635. HMSO, 1989.

http://www.opsi.gov.uk/si/si1989/Uksi_19890635_en_1.htm

Electricity Safety, Quality and Continuity Regulations 2002. SI 2002 No 2665. HMSO, 2002.

<http://www.opsi.gov.uk/si/si2002/20022665.htm>

Electromagnetic Compatibility Regulations 1992. SI 1992 No 2372. HMSO, 1992.

http://www.opsi.gov.uk/si/si1992/Uksi_19922372_en_1.htm

Health and Safety (Safety Signs and Signals) Regulations 1996. SI 1996 No 341. HMSO, 1996.

http://www.opsi.gov.uk/si/si1996/Uksi_19960341_en_1.htm

Health and Safety at Work etc Act 1974. HMSO, 1974.

Health and Safety (First-aid) Regulations 1981. HMSO, 1981.

Management of Health and Safety at Work Regulations 1999. SI 1999 No 3242. HMSO, 1999.

<http://www.opsi.gov.uk/si/si1999/19993242.htm>

Manual Handling Operations Regulations 1992. SI 1992 No 2793. HMSO, 1992.

http://www.opsi.gov.uk/si/si1992/Uksi_19922793_en_1.htm

Personal Protective Equipment Regulations 2002. SI 2002 No 1144. HMSO, 2002.

<http://www.opsi.gov.uk/si/si2002/20021144.htm>

Provision and Use of Work Equipment Regulations 1998. SI 1998 No 2306. HMSO, 1998.

<http://www.opsi.gov.uk/si/si1998/19982306.htm>

Reporting of Injuries, Diseases and Dangerous Occurrences Regulations 1995. SI 1995 No 3163.

http://www.opsi.gov.uk/si/si1995/Uksi_19953163_en_1.htm

Workplace (Health, Safety and Welfare) Regulations 1992. SI 1992 No 3004. HMSO, 1992.

http://www.opsi.gov.uk/si/si1992/Uksi_19923004_en_1.htm

British Standards

BS 697:1986. Specification for rubber gloves for electrical purposes. British Standards Institution, 1986.

BS 921:1976. Specification. Rubber mats for electrical purposes. British Standards Institution, 1976.

BS 2559-3:1973. Specification for screwdrivers. Insulated screwdrivers. British Standards Institution, 1973.

BS 3087-1:1991. Pliers and nippers. General introduction. British Standards Institution, 1991.

BS 5252:1976. Framework for colour co-ordination for building purposes. British Standards Institution, 1976.

BS 5499-5:2002. Graphical symbols and signs. Safety signs, including fire safety signs. Signs with specific safety meanings. British Standards Institution, 2002.

BS 7430:1998. Code of practice for earthing. British Standards Institution, 2001.

BS 7671:2001. Requirements for electrical installations. IEE Wiring Regulations. Sixteenth edition. British Standards Institution, 2001. British Standards Institution, 2001.

BS EN 166:2002. Personal eye protection. Specifications. British Standards Institution, 2002.

BS EN 167:2002. Personal eye protection. Optical test methods. British Standards Institution, 2002.

BS EN 168:2002. Personal eye protection. Non-optical test methods. British Standards Institution, 2002.

BS EN 354:2002. Personal protective equipment against falls from a height. Lanyards. British Standards Institution, 2002.

BS EN 355:2002. Personal protective equipment against falls from a height. Energy absorbers. British Standards Institution, 2002.

BS EN 361:2002. Personal protective equipment against falls from a height. Full body harnesses. British Standards Institution, 2002.

BS EN 362:2004. Personal protective equipment against falls from a height. Connectors. British Standards Institution, 2004.

BS EN 363:2002. Personal protective equipment against falls from a height. Fall arrest systems. British Standards Institution, 2002.

BS EN 364:1993. Personal protective equipment against falls from a height. Test methods. British Standards Institution, 1993.

BS EN 365:2004. Personal protective equipment against falls from a height. General requirements for instructions for use, maintenance, periodic examination, repair, marking and packaging. British Standards Institution, 2004.

BS EN 60529:1992. Specification for degrees of protection provided by enclosures (IP code). British Standards Institution, 1992.

BS EN 60900:2004. Live working. Hand tools for use up to 1000 V ac and 1500 V dc. British Standards Institution, 2004.

BS EN 60903:2003. Live working. Gloves of insulating material. British Standards Institution, 2003.

BS EN ISO 9001:2000. Quality management systems. Requirements. British Standards Institution, 2000.

Department of Health publications

Health Technical Memorandum 00 – Policies and principles. The Stationery Office, 2006.

Health Technical Memorandum 06-01 – Electrical services supply and distribution. The Stationery Office, 2006.

Health Technical Memorandum 06-02 – Electrical safety code for low voltage systems. The Stationery Office, 2006.

Other publications

Health & Safety Executive (1989). **Memorandum of guidance on the Electricity at Work Regulations 1989. Guidance on Regulations HSR25.** HSE Books, 1989.

Health & Safety Executive (1993). **Electricity at work: safe working practices HSG85.** HSE Books, 1993.

Health & Safety Executive (1994). **Maintaining portable and transportable electrical equipment HSG107.** HSE Books, 1994.

Health & Safety Executive (1995). **Electrical safety on construction sites HSG141.** HSE Books, 1995

Health & Safety Executive (1995). **Guidance Note GS38: Electrical test equipment for use by electricians.** HSE Books, 1995.

Health & Safety Executive (1997). **Avoidance of danger from overhead electric lines GS6.** HSE Books, 1997.

Health & Safety Executive (1997). **First-aid at work. The Health and Safety (First-Aid) Regulations 1981. Approved Code of Practice and Guidance L74.** HSE Books, 1997.

Health & Safety Executive (2000). **Avoiding danger from underground services HSG47.** HSE Books, 2000.

Health & Safety Executive (2000). **Management of health and safety at work. Management of Health and Safety at Work Regulations 1999. Approved Code of Practice and guidance L21.** HSE Books, 2000.

Health & Safety Executive (2000). **Memorandum of guidance on the Electricity at Work Regulations 1989 HSR25.** HSE Books, 2000.

Health & Safety Executive (2002). **Keeping electrical switchgear safe HSG230.** HSE Books, 2002.

Health & Safety Executive (2002). **Safety in electrical testing at work INDG354.** HSE Books, 2002.

Institution of Electrical Engineers (2001). **Code of Practice for in-service inspection and testing of electrical equipment.** IEE, 2001.

Institution of Electrical Engineers (2002). **Guidance Note 3 – Inspection and testing. 4th Edition.** IEE, 2002.